

Please cut where indicated and insert the label into the plastic pocket on the spine of the binder.

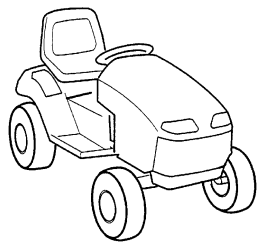

**GARDEN TRACTOR
REPAIR**

GT18, GT20, GT22

Vol. 1
86620471

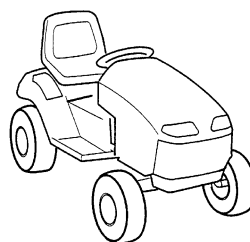

**GARDEN TRACTOR
REPAIR**

GT18, GT20, GT22

Vol. 1
86620471



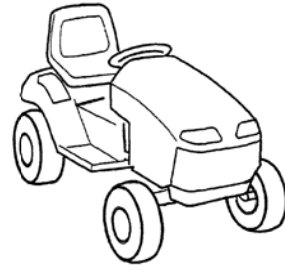

NEW HOLLAND

GT18

GT20

GT22

Section 1 - Engine Systems

**REPAIR
MANUAL**



GT18, GT20, GT22 REPAIR MANUAL CONTENTS



SECTION 1 - ENGINE SYSTEMS

SECTION 2 - ELECTRICAL

SECTION 3 - PTO SYSTEM

SECTION 4 - HYDROSTATIC TRANSMISSIONS

SECTION 5 - HYDRAULICS

SECTION 6 - STEERING AND FRONT AXLE

SECTION 7 - LIFT LINKAGE

SECTION 8 - SPECIFICATIONS

SECTION 9 - MOWER DECKS

SECTION 1 - ENGINE SYSTEMS

CONTENTS

GT18 AND GT22 KOHLER ENGINES

Description	Page
Safety and General Information	1-2
Special Tools	1-18
Troubleshooting	1-22
Air Cleaner and Air Intake System	1-26
Fuel System and Governor	1-30
Lubrication System	1-44
Retractable Starter	1-49
Electrical System and Components	1-55
Disassembly	1-80
Inspection and Reconditioning	1-104
Reassembly	1-122

GT20 KAWASAKI ENGINES

General Information	1-159
Fuel System	1-167
Cooling System	1-187
Engine Top End	1-211
Lubrication System	1-241
Camshaft/Crankshaft	1-253
Electric System	1-269
Troubleshooting	1-300



GT18 AND GT22 KOHLER ENGINES



SAFETY AND GENERAL INFORMATION

Safety Information

These precautions should be followed at all times. Failure to follow these precautions could result in injury to yourself and others.

For Your Safety!

 WARNING

Explosive Fuel can cause fires and severe burns. Stop engine before filling fuel tank.

 WARNING

Rotating Parts can cause severe injury. Stay away while engine is in operation.

 WARNING

Hot Parts can cause severe burns. Do not touch engine while operating or just after stopping.

Explosive Fuel!

Gasoline is extremely flammable and its vapors can explode if ignited. Store gasoline only in approved containers, in well ventilated, unoccupied buildings, away from sparks or flames. Do not fill the fuel tank while the engine is hot or running, since spilled fuel could ignite if it comes in contact with hot parts or sparks from ignition. Do not start the engine near spilled fuel. Never use gasoline as a cleaning agent.

Rotating Parts!

Keep hands, feet, hair, and clothing away from all moving parts to prevent injury. Never operate the engine with covers, shrouds, or guards removed.

Hot Parts!



Engine components can get extremely hot from operation. To prevent severe burns, do not touch these areas while the engine is running—or immediately after it is turned off. Never operate the engine with heat shields or guards removed.

 WARNING

<p>Accidental Starts can cause severe injury or death.</p> <p>Disconnect and ground spark plug lead before servicing.</p>



Accidental Starts!

Before servicing the engine or equipment, always disconnect the spark plug leads to prevent the engine from starting accidentally. Ground the leads to prevent sparks that could cause fires. Make sure the equipment is in neutral.

 WARNING

<p>Carbon Monoxide can cause severe nausea, fainting or death.</p> <p>Do not operate engine in closed or confined area.</p>

Lethal Exhaust Gases!

Engine exhaust gases contain poisonous carbon monoxide. Carbon monoxide is odorless, colorless, and can cause death if inhaled. Avoid inhaling exhaust fumes, and never run the engine in a closed building or confined area.

 WARNING

<p>Explosive Gas can cause fires and severe acid burns.</p> <p>Charge battery only in a well ventilated area. Keep sources of ignition away.</p>

Explosive Gas!

Batteries produce explosive hydrogen gas while being charged. To prevent a fire or explosion, charge batteries only in well ventilated areas. Keep sparks, open flames, and other sources of ignition away from the battery at all times. Keep batteries out of the reach of children. Remove all jewelry when servicing batteries.

 WARNING

<p>Cleaning Solvents can cause severe injury or death.</p> <p>Use only in well ventilated areas away from ignition sources.</p>

Flammable Solvents!



Carburetor cleaners and solvents are extremely flammable. Keep sparks, flames, and other sources of ignition away from the area. Follow the cleaner manufacturer's warnings instructions on its proper and safe use. Never use gasoline as a cleaning agent.

 WARNING

<p>Uncoiling Spring can cause severe injury.</p> <p>Wear safety goggles or face protection when servicing retractable starter.</p>

Spring Under Tension!

Retractable starters contain a powerful, recoil spring that is under tension. Always wear safety goggles when servicing retractable starters and carefully follow instructions in the "Retractable Starters Section 7 for relieving spring tension.

 CAUTION

<p>Electrical Shock can cause injury.</p> <p>Do not touch wires while engine is running.</p>

Electrical Shock!

Never touch electrical wires or components while the engine is running. They can be sources of electrical shock.

Engine Identification Numbers

When ordering parts, or in any communication involving an engine, always give the Model, Specification and Serial Numbers, including letter suffixes if there are any.

The engine identification numbers appear on a decal, or decals, affixed to the engine shrouding. See Figure 1-1. An explanation of these numbers is shown in Figure 1-2.

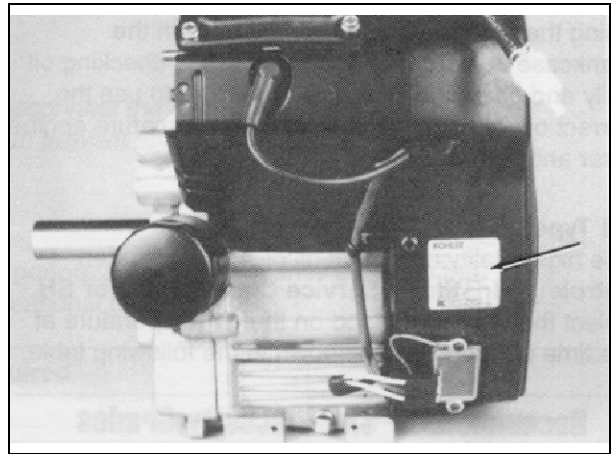

1

Engine Identification Plate Location

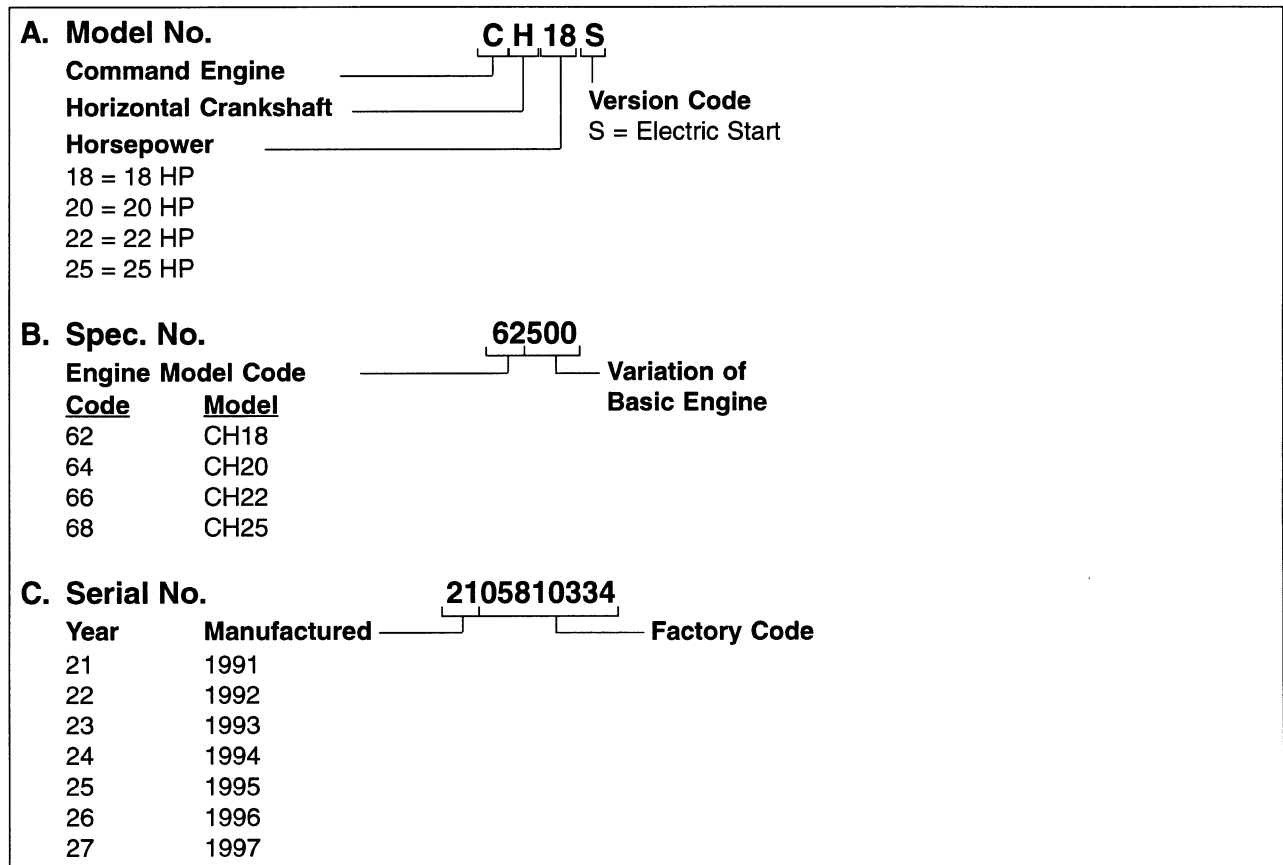

2

Explanation of Engine Identification Numbers

Oil Recommendations

Using the proper type and weight of oil in the crankcase is extremely important. So is checking oil daily and changing oil regularly. Failure to use the correct oil, or using dirty oil, causes premature engine wear and failure.

Oil Type

Use high quality detergent oil of API (American Petroleum Institute) Service Class SF, SG or SH. Select the viscosity based on the air temperature at the time of operation as shown in the following table.

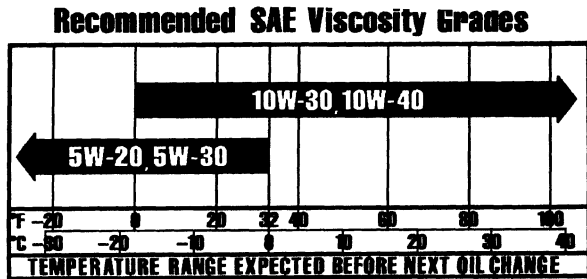

NOTE: Using other than service class SF, SO or SH oil or extending oil change intervals longer than recommended can cause engine damage.

A logo or symbol on oil containers identifies the API service class and SAE viscosity grade.

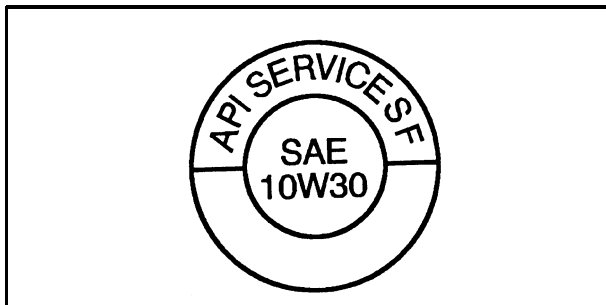

Oil Coolant Logo

3

Refer to Section 6—“Lubrication System” for detailed procedures on checking the oil, changing the oil and changing the oil filter.

Fuel Recommendations

⚠ WARNING ⚠
Explosive Fuel!

Gasoline is extremely flammable and its vapors can explode if ignited. Store gasoline only in approved containers, in well ventilated, unoccupied buildings, away from sparks or flames. Do not fill the fuel tank while the engine is hot or running, since spilled fuel could ignite if it comes in contact with hot parts or sparks from ignition. Do not start the engine near spilled fuel. Never use gasoline as a cleaning agent.

General Recommendations

Purchase gasoline in small quantities and store in clean, approved containers. A container with a capacity of 2 gallons or less with a pouring spout is recommended. Such a container is easier to handle and helps eliminate spillage during refueling.

Do not use gasoline left over from the previous season, to minimize gum deposits in your fuel system and to ensure easy starting.

Do not add oil to the gasoline.

Do not overfill the fuel tank. Leave room for the fuel to expand.

Fuel Type

For best results, use only clean, fresh, unleaded gasoline with a pump sticker octane rating of 87 or higher. In countries using the Research method, it should be 90 octane minimum.

Unleaded gasoline is recommended, as it leaves fewer combustion chamber deposits. Leaded gasoline may be used in areas where unleaded is not available and exhaust emissions are not regulated. Be aware, however, that the cylinder head will require more frequent service.

Gasoline/Alcohol blends

Gasohol (up to 10% ethyl alcohol, 90% unleaded gasoline by volume) is approved as a fuel for Kohler engines. Other gasoline/alcohol blends are not approved.

Gasoline/Ether blends

Methyl Tertiary Butyl Ether (MTBE) and unleaded gasoline blends (up to a maximum of 15% MTBE by volume) are approved as a fuel for Kohler engines. Other ether blends are not approved.

Periodic Maintenance



Accidental Starts!

Before servicing the engine or equipment, always disconnect the spark plug leads to prevent the engine from starting accidentally. Ground the leads to prevent sparks that could cause fires. Make sure the equipment *is* in neutral.

Maintenance Schedule

These required maintenance procedures should be performed at the frequency stated in the table. They should also be included as part of any seasonal tune up.

Frequency	Maintenance Required	Refer to:
Daily or Before Starting Engine	Fill fuel tank. Check oil level. Check air cleaner for dirty ¹ , loose, or damaged parts. Check air intake and cooling areas, clean as necessary ¹ .	Section 5 Section 6 Section 4 Section 4
Every 25 Hours	Service precleaner element ¹ .	Section 4
Every 100 Hours	Service air cleaner element ¹ . Change oil. Remove cooling shrouds and clean cooling areas ¹ .	Section 4 Section 6 Section 4
Every 200 Hours	Change oil filter. Check spark plug condition and gap.	Section 6 Section 8

¹ Perform these maintenance procedures more frequently under extremely dusty, dirty conditions.

Storage

If the engine will be out of service for two months or more, use the following storage procedure:

1. Clean the exterior surfaces of the engine.
2. Change the oil and oil filter while the engine is still warm from operation. See "Change Oil and Oil Filter" in Section 6.
3. The fuel system must be completely emptied, or the gasoline must be treated with a stabilizer to prevent deterioration. If you choose to use a stabilizer, follow the manufacturer's

recommendations, and add the correct amount for the capacity of the fuel system. Fill the fuel tank with clean, fresh gasoline. Run the engine for 2 to 3 minutes to get stabilized fuel into the carburetor.

To empty the system, drain the fuel tank and carburetor, or run the engine until the tank and system are empty.

4. Remove the spark plugs and add one tablespoon of engine oil into each spark plug hole. Install plugs and **ground** spark plug leads do not connect the leads to the plug. Crank the engine two or three revolutions.
5. Store the engine in a clean, dry place.

SECTION 1 - ENGINE SYSTEMS

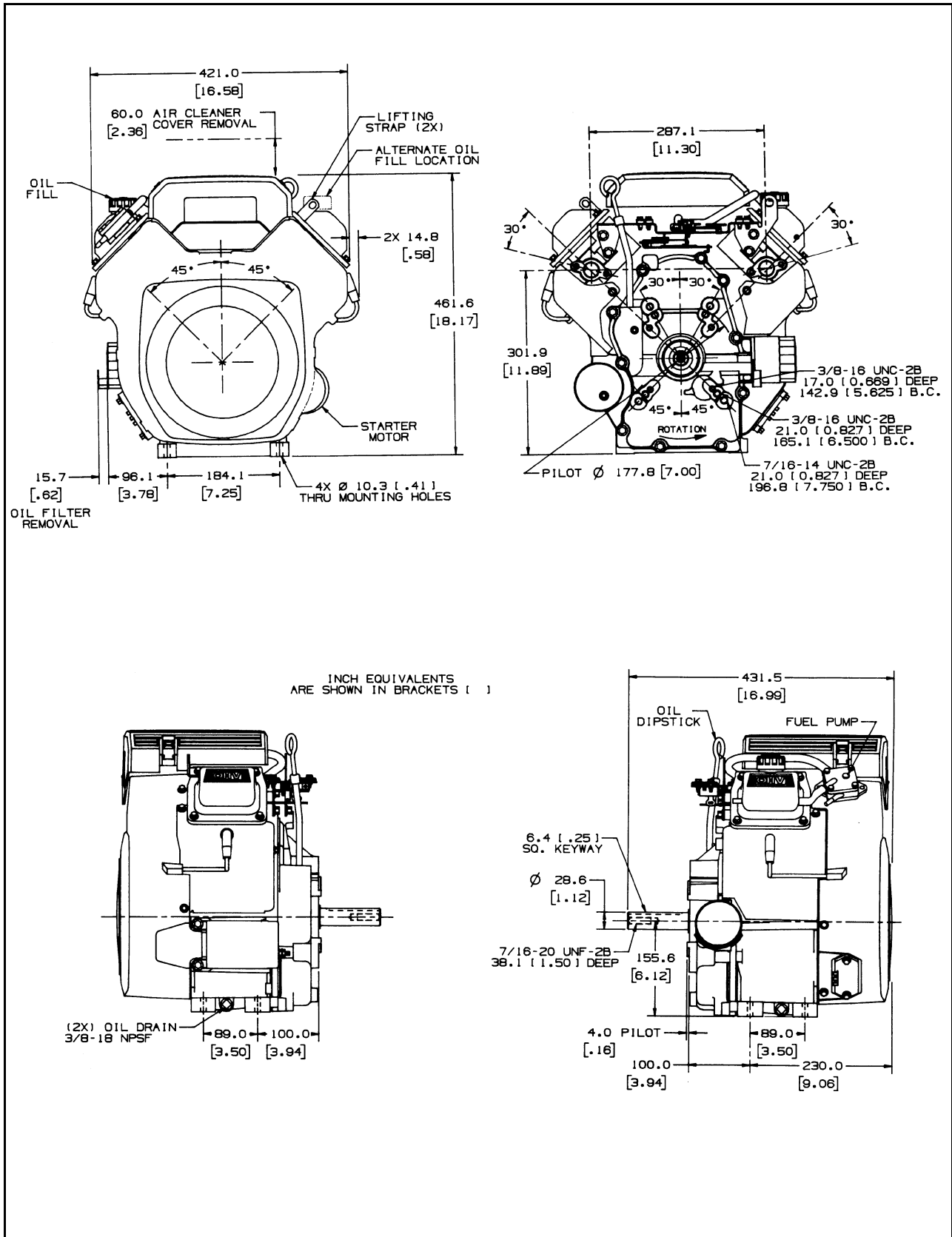

Typical Engine Dimensions CH18-22

SECTION 1 - ENGINE SYSTEMS

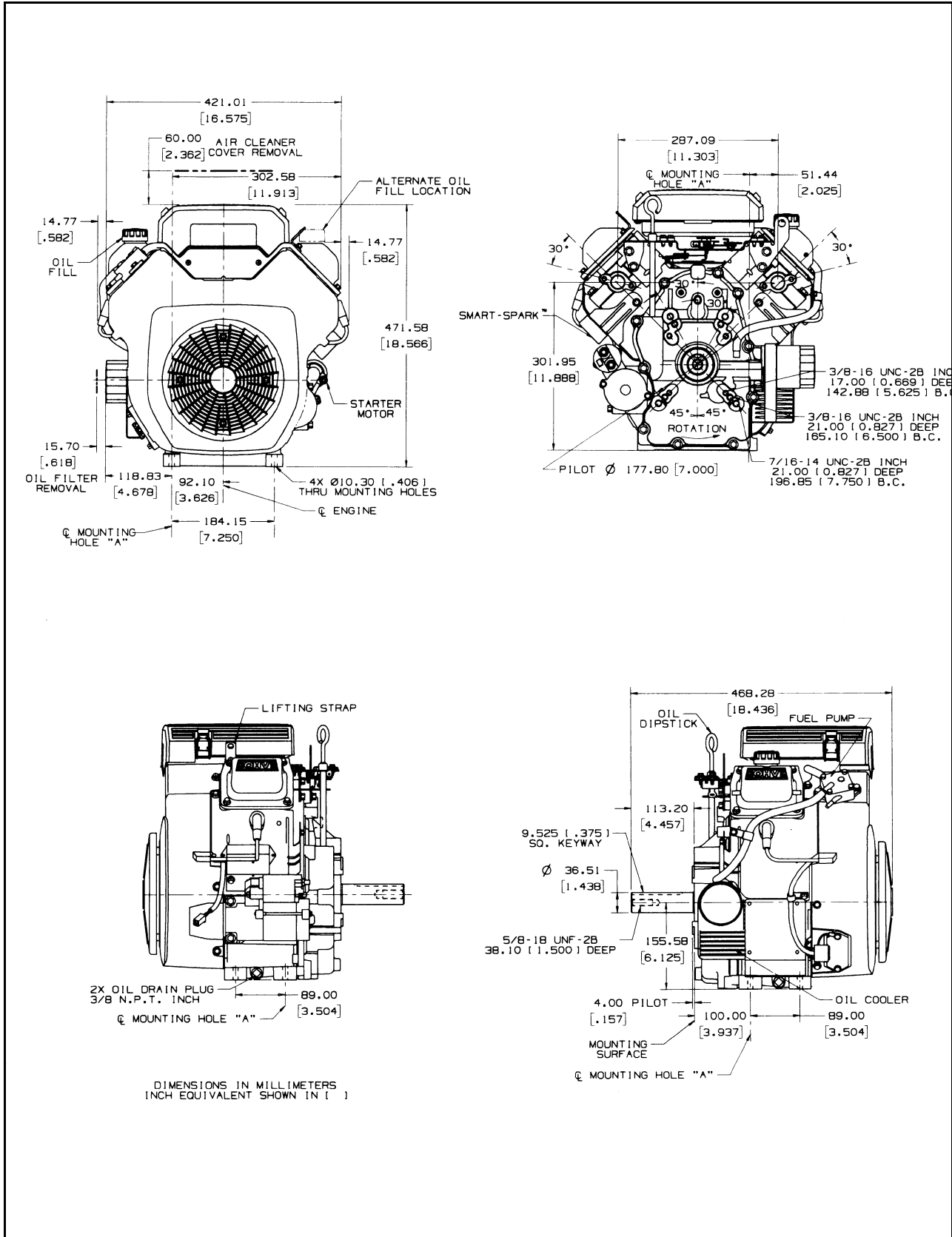

Typical Engine Dimensions CH25

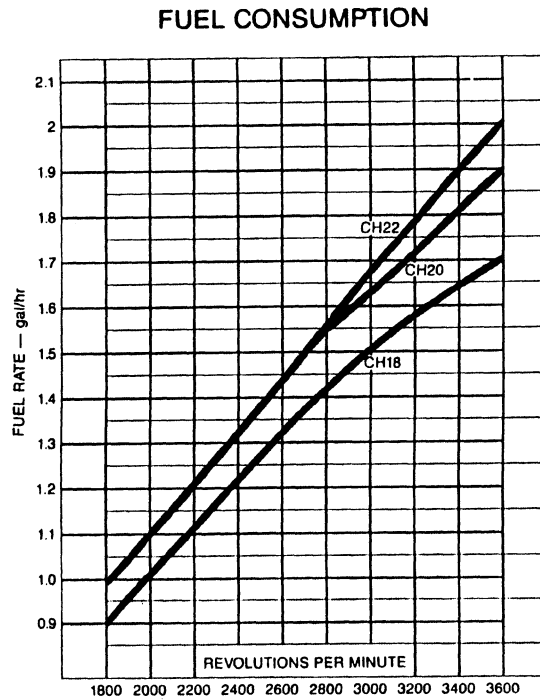
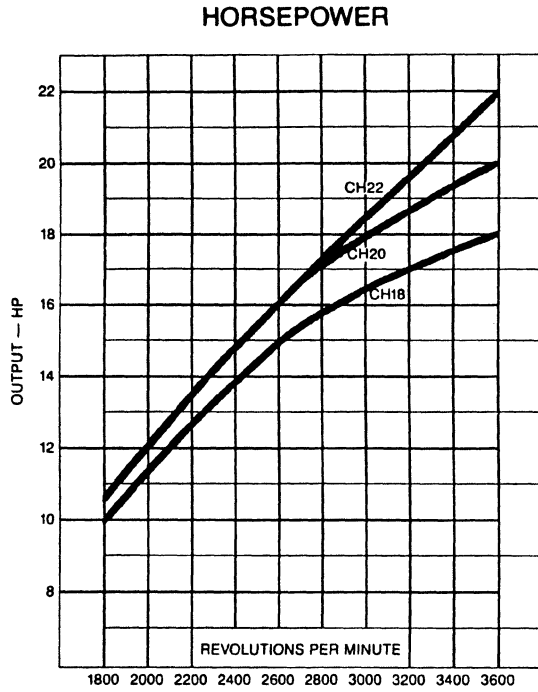
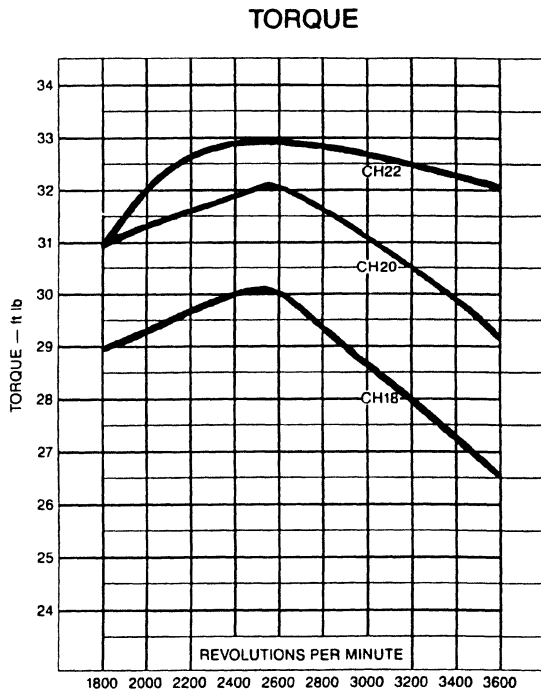

Torque, Horsepower and Fuel Curves CH18-22

CH25 TORQUE CURVE

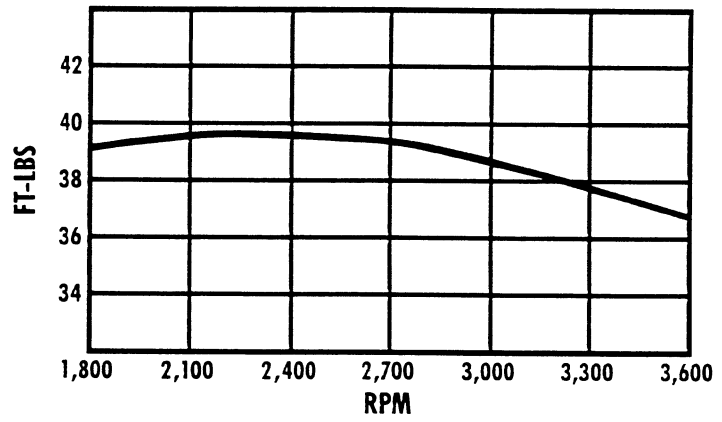

CH25 POWER CURVE

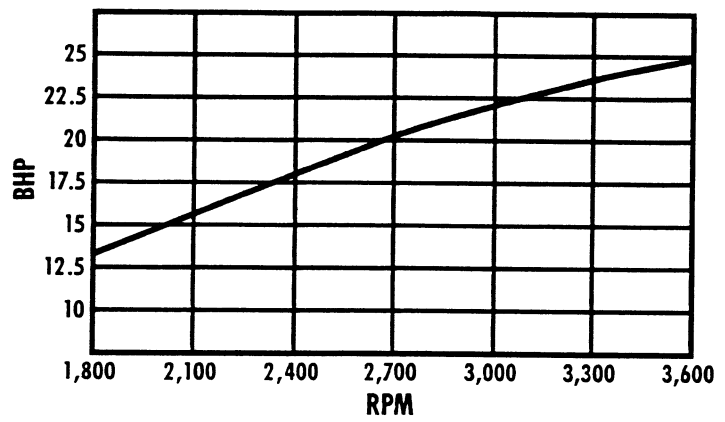

CH25 FUEL RATE (at WOT)

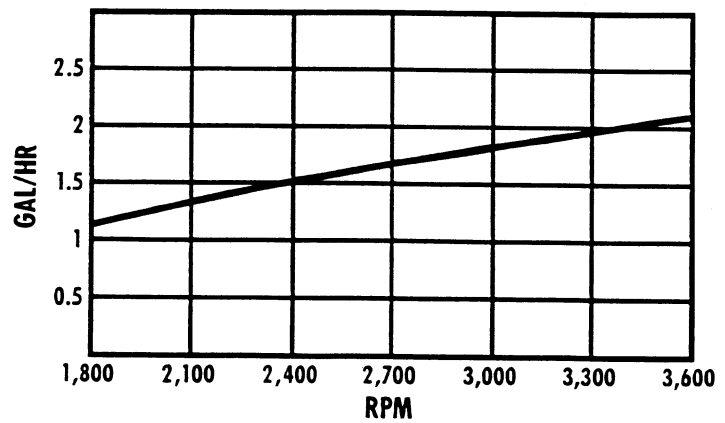

Specifications, Tolerances, and Special Torque Values

Description

General Specifications

Power (@ 3600 RPM, corrected to SAE J1349)

CH18	13.4kW(18HP)
CH20	14.9 kW (20HP)
CH22	16.4 kW (22 HP)
CH25	18.6 kW (25 HP)

Peak Torque (See Torque Curves)

CH18 @ 2500 RPM	41 N·m (30 ft. lb.)
CH20 @ 2500 RPM	44 N·m (32 ft. lb.)
CH22 @ 2500 RPM	45 N·m (33 ft. lb.)
CH25 @ 2500 RPM	53 N·m (39.5 ft. lb.)

Bore

CH18, CH20, CH22	77 mm (3.03 in.)
CH25	83 mm (3.27 in.)

Stroke 67 mm (2.64 in.)

Displacement

CH18, CH20, CH22	624 cc (38 cu. in.)
CH25	725 cc (44 cu. in.)

Compression Ratio

CH18, CH20, CH22	8.5:1
CH25	9.0:1

Dry Weight

CH18, CH20, CH22	41 kg (90 lb.)
CH25	43 kg (94 lb.)

Oil Capacity (with filter)

CH18, CH20, CH22	2.0 U.S. qt. (1.9 L)
CH25	2.1 U.S. qt. (2.0 L)

Angle of Operation Maximum (At Full Oil Level) All Directions 25°

Blower Housing and Sheet Metal

M5 Fasteners Torque	4.7 N·m (35 in. lb.)
M6 Fasteners Torque	8.6 N·m (65 in. lb.)
Rectifier Fastener Torque	4.7 N·m (35 in. lb.)

Camshaft

End Play (With Shim) 0.076/0.127 mm (0.0030/0.0050 in.)

Running Clearance 0.025/0.063 mm (0.0010/0.0025 in.)

Bore I.D.

New 20.00/20.25 mm (0.7874/0.7884 in.)

Max. Wear Limit 20.038 mm (0.7889 in.)

Camshaft Bearing Surface O.D.

New 19.962/19.975 mm (0.7859/0.7864 in.)

Max. Wear Limit 19.959 mm (0.7858 in.)

Carburetor and Intake Manifold

Intake Manifold Mounting Fasteners Torque 9.9 N·m (88 in. lb.)

Carburetor Mounting Fasteners Torque 9.9 N·m (88 in. lb.)

Connecting Rod

Cap Fastener Torque 17.3 N·m (130 in. lb.)

Connecting Rod to Crankpin Running Clearance

.New 0.030/0.055 mm (0.0012/0.0022 in.)

Max. Wear Limit 0.07 mm (0.0028 in.)

Connecting Rod to Crankpin Side Clearance 0.26/0.63 mm (0.0102/0.0248 in.)

Connecting Rod to Piston Pin Running Clearance 0.015/0.028 mm (0.0006/0.0011 in.)

Piston Pin End I.D.

New 17.015/17.023 mm (0.6699/0.6702 in.)

Max. Wear Limit 17.036 mm (0.6707 in.)

Crankcase

Governor Cross Shaft Bore I.D.

New 6.025/6.050 mm (0.2372/0.2382 in.)

Max. Wear Limit 6.063 mm (0.2387 in.)

Breather Cover Mounting Fasteners 8.6 N·m (65 in. lb.)

Oil Drain Plugs 13.6 N·m (10 ft. lb.)

Crankshaft

End Play (Free) 0.070/0.480 mm (0.0028/0.0189 in.)

End Play (With Thrust Bearing Components) 0.050 to 0.5 mm (0.0020/0.0197 in.)

Except CH25 Engines Below Serial No. 2403500008 0.050/0.75 mm (0.0020/0.0295 in.)

Crankshaft Sleeve Bearing I.D. (Crankcase)

New 40.965/41.003 mm (1.6128/1.6143 in.)

Max. Wear Limit 41.016 mm (1.6148 in.)

Crankshaft (Cont'd)

Crankshaft to Sleeve Bearing (Crankcase)

Running Clearance - New 0.03/0.09 mm (0.0012/0.0035 in.)

Crankshaft Bore (In Closure Plate) - New 40.987/40.974 mm (1.6128/1.6143 in.)

Crankshaft Bore (In Closure Plate)-to-Crankshaft

Running Clearance - New 0.039/0.074 mm (0.0015/0.0029 in.)

Flywheel End Main Bearing Journal

O.D; New 40.913/40.935 mm (1.6107/1.6116 in.)

O.D. Max. Wear Limit 40.84 mm (1.608 in.)

Max. Taper 0.022 mm (0.0009 in.)

Max. Out of Round 0.025 mm (0.0010 in.)

Closure Plate End Main Bearing Journal

O.D. New 40.913/40.935 mm (1.6107/1.6116 in.)

O.D. Max. Wear Limit 40.84 mm (1.608 in.)

Max. Taper 0.022 mm (0.0009 in.)

Max. Out of Round 0.025 mm (0.0010 in.)

Connecting Rod Journal

O.D. - New 35.955/35.973 mm (1.4156/1.4163 in.)

O.D. Max. Wear Limit 35.94 mm (1.415 in.)

Max. Taper 0.018 mm (0.0007 in.)

Max. Out of Round 0.025 mm (0.0010 in.)

Crankshaft T.I.R.

PTO End, Crank in Engine 0.15 mm (0.0059 in.)

Entire Crank, in V Blocks 0.10 mm (0.0039 in.)

Cylinder Bore

Cylinder Bore I.D.

New - CH18, CH20, CH22 77.000/77.025 mm (3.0315/3.0325 in.)

New - CH25 82.988/83.013 mm (3.3195/3.3205 in.)

Max. Wear Limit CH18, CH20, CH22 77.063 mm (3.0340 in.)

Max. Wear Limit CH25 83.051 mm (3.3220 in.)

Max. Out of Round 0.12 mm (0.0047 in.)

Max. Taper 0.05 mm (0.0020 in.)

Cylinder Head

Cylinder Head Fastener Torque 40.7 N·m (30 ft. lb.)

Max. Out of Flatness 0.076 mm (0.003 in.)

Rocker Pivot Fastener Torque 14 N·m (124 in.)

Electric Starter

Starter Mounting Fastener Torque 15.3 N·m (135 in. lb.)

Fan/Flywheel

Fan Fastener Torque 9.9 N·m (88 in. lb.)
 Flywheel Retaining Screw Torque 66.4 N·m (49 ft. lb.)

Governor

Governor Cross Shaft to Crankcase
 Running Clearance 0.013/0.075 mm (0.0005/0.0030 in.)

Governor Cross Shaft O.D.

New 5.975/6.012 mm (0.2352/0.2367 in.)
 Max. Wear Limit 5.962 mm (0.2347 in.)

Governor Gear Shaft to Governor

Gear Running Clearance 0.015/0.140 mm (0.0006/0.0055 in.)

Governor Gear Shaft O.D.

New 5.990/6.000 mm (0.2358/0.2362 in.)
 Max. Wear Limit 5.977 mm (0.2353 in.)

Ignition

Spark Plug Type (Champion or Equivalent) RC12YC

Spark Plug Gap 1.02 mm (0.040 in.)

Spark Plug Torque 24.4/29.8 N·m (18/22 ft. lb.)

Ignition Module Air Gap 0.2/0.3 mm (0.008/0.012 in.)

Ignition Module Fastener Torque 4.0/6.2 N·m (35/55 in. lb.)

Muffler

Muffler Retaining Nuts Torque 24.4 N·m (216 in. lb.)

Oil Filter/Closure Plate/Oil Cooler

Oil Filter Torque 5.7/9.0 N·m (50/80 in. lb.)

Oil Cooler Torque (Std. CH25 Option on Others) 40.6 N·m (30 ft. lb.)

Closure Plate Fastener Torque 24.4 N·m (216 in. lb.)

Piston, Piston Rings, and Piston Pin

Piston to Piston Pin (Selective Pin) 0.006/0.017 mm (0.0002/0.0007 in.)

Piston Pin Bore I.D.

New 17.006/17.012 mm (0.6695/0.6698 in.)
 Max. Wear Limit 17.025 mm (0.6703 in.)

Piston Pin O.D.

New 16.995/17.000 mm (0.6691/0.6693 in.)
 Max. Wear Limit 16.994 mm (0.6691 in.)

Piston, Piston Rings, and Piston Pin (Cont'd)

Top Compression Ring to Groove	
Side Clearance - CH18, CH20, CH22	0.040/0.080 mm (0.0016/0.0031 in.)
Side Clearance CH25	0.025/0.048 mm (0.0010/0.0019 in.)
Middle Compression Ring to Groove	
Side Clearance - CH18, CH20, CH22	0.040/0.072 mm (0.0016/0.0028 in.)
Side Clearance - CH25	0.015/0.037 mm (0.0006/0.0015 in.)
Oil Control Ring to Groove	
Side Clearance - CH18, CH20, CH22	0.060/0.202 mm (0.0024/0.0080 in.)
Side Clearance CH25	0.026/0.176 mm (0.0010/0.0070 in.)
Top and Center Compression Ring End Gap	
New Bore CH18, CH20, CH22	0.25/0.45 mm (0.0098/0.0177 in.)
New Bore CH25	0.25/0.56 mm (0.0100/0.0224 in.)
Used Bore (Max.) CH18, CH20, CH22	0.77 mm (0.030 in.)
Used Bore (Max.) CH25	0.94 mm (0.037 in.)
Piston Thrust Face O.D.2	
New CH18, CH20, CH22	76.967/76.985 mm (3.0302/3.0309 in.)
New CH25	82.986 mm (3.3194 in.)
Max. Wear Limit CH18, CH20, CH22	76.840 mm (3.0252 in.)
Max. Wear Limit CH25	82.841 mm (3.3136 in.)
Piston Thrust Face to Cylinder Bore Running Clearance	
New - CH18, CH20, CH25	0.015/0.058 mm (0.0006/0.0023 in.)
New - CH25	0.002/0.045 mm (0.001/0.0018 in.)

Speed Control

Speed Control Bracket Assembly	
Fastener Torque	7.3/10.7 N·m (65/95 in. lb.)

Stator

Mounting Screw Torque	4.0 N·m (35 in. lb.)
-----------------------------	----------------------

Throttle/Choke Controls

Governor Control Lever Fastener Torque	9.9 N·m (88 in. lb.)
--	----------------------

Valve Cover/Rocker Arms

Valve Cover Fastener Torque	3.4 N·m (30 in. lb.)
-----------------------------------	----------------------

Valves and Valve Lifters

Hydraulic Valve Lifter to Crankcase Running Clearance	0.0124/0.0501 mm (0.0005/0.0020 in.)
Intake Valve Stem to Valve Guide Running Clearance	0.038/0.076 mm (0.0015/0.0030 in.)
Exhaust Valve Stem to Valve Guide Running Clearance	0.050/0.088 mm (0.0020/0.0035 in.)

SECTION 1 - ENGINE SYSTEMS

Valve and Valve Lifters (Cont'd)

Intake Valve Guide I.D.

New 7.038/7.058 mm (0.2771/0.2779 in.)
 Max. Wear Limit 7.134 mm (0.2809 in.)

Exhaust Valve Guide I.D.

New 7.038/7.058 mm (0.2771/0.2779 in.)
 Max. Wear 7.159 mm (0.2819 in.)

Valve Guide Reamer Size

Standard 7.048 mm (0.2775 in.)
 0.25 mm O.S 7.298 mm (0.2873 in.)











Intake Valve Minimum 8.07 mm (0.3177 in.)

Exhaust Valve Minimum Lift 8.07 mm (0.3177 in.)

Nominal Valve Seat Angle 45°

General Torque Values

Metric Fastener Torque Recommendations for Standard Applications

Tightening Torque: N•m (in. lb.) + or - 10%						
Property Class						
						Noncritical Fasteners Into Aluminum
Size						
M4	1.2 (11)	1.7 (15)	2.9 (26)	4.1 (36)	5.0 (44)	2.0 (18)
M5	2.5 (22)	3.2 (28)	5.8 (51)	8.1 (72)	9.7 (86)	4.0 (35)
M6	4.3 (38)	5.7 (50)	9.9 (88)	14.0 (124)	16.5 (146)	6.8 (60)
M8	10.5 (93)	13.6 (120)	24.4 (216)	33.9 (300)	40.7 (360)	17.0 (150)
Tightening Torque: N•m (ft. lb.) + or - 10%						
Property Class						
						Noncritical Fasteners Into Aluminum
Size						
M10	21.7 (16)	27.1 (20)	47.5 (35)	66.4 (49)	81.4 (60)	33.9 (25)
M12	36.6 (27)	47.5 (35)	82.7 (61)	116.6 (86)	139.7 (103)	61.0 (45)
M14	58.3 (43)	76.4 (55)	131.5 (97)	184.4 (136)	219.7 (162)	94.9 (70)

Torque Conversions

N•m = in. lb. x 0.113
N•m = ft. lb. x 1.356
in. lb. = N•m x 8.85
ft. lb. = N•m x 0.737

**Thanks very much for your reading,
Want to get more information,
Please click here, Then get the complete
manual**

JustClickHere 

NOTE:

**If there is no response to click on the link above,
please download the PDF document first, and then
click on it.**

**Have any questions please write to me:
admin@servicemanualperfect.com**