

540G, 640G, 740G, Skidder and 548G, 648G, 748G Grapple Skidder (S.N. —565684) Repair

TECHNICAL MANUAL 540G, 640G, 740G, Skidder and 548G, 648G, 748G Grapple Skidder (S.N. —565684) Repair

TM1600 03AUG98 (ENGLISH)

For complete service information also see:

540G, 640G, 740G Skidder and 548G, 648G, 748G Grapple Skidder (S.N. —565684)	
Operation and Test	TM1599
4045, 6059, 6068 Engine	CTM8
6076 Engine	CTM42
Starting Motors and Alternators	CTM77
John Deere PowerTech 4.5 L and 6.8 L Engine	CTM104
John Deere PowerTech 8.1 L Engine	CTM86
4000 Series Winch	CTM25
6000 Series Winch	CTM41
TeamMate II Axles	CTM43

**Worldwide Construction
And Forestry Division**

LITHO IN U.S.A.

Introduction

Foreword

This manual is written for an experienced technician. Essential tools required in performing certain service work are identified in this manual and are recommended for use.

Live with safety: Read the safety messages in the introduction of this manual and the cautions presented throughout the text of the manual.



This is the safety-alert symbol. When you see this symbol on the machine or in this manual, be alert to the potential for personal injury.

Technical manuals are divided in two parts: repair and operation and tests. Repair sections tell how to repair the components. Operation and tests sections help you identify the majority of routine failures quickly.

Information is organized in groups for the various components requiring service instruction. At the beginning of each group are summary listings of all applicable essential tools, service equipment and tools, other materials needed to do the job, service parts kits, specifications, wear tolerances, and torque values.

Technical Manuals are concise guides for specific machines. They are on-the-job guides containing only the vital information needed for diagnosis, analysis, testing, and repair.

Fundamental service information is available from other sources covering basic theory of operation, fundamentals of troubleshooting, general maintenance, and basic type of failures and their causes.

DX, TMIFC -19-22MAY92-1/1

Contents

SECTION 00—General Information

- Group 0001—Safety Information
- Group 0002—General Specifications
- Group 0003—Torque Values
- Group 0004—Fuels and Lubricants

SECTION 01—Wheels

- Group 0110—Powered Wheels and Fastenings

SECTION 02—Axles and Suspension System

- Group 0200—Removal and Installation
- Group 0225—Input Drive Shafts and U-Joints
- Group 0260—Hydraulic System

SECTION 03—Transmission

- Group 0300—Removal and Installation
- Group 0315—Control Linkage
- Group 0325—Input Drive Shafts and U-Joints
- Group 0350—Gears, Shafts and Bearings
- Group 0360—Hydraulic System

SECTION 04—Engine

- Group 0400—Removal and Installation

SECTION 05—Engine Auxiliary Systems

- Group 0505—Cold Weather Starting Aids
- Group 0510—Cooling Systems
- Group 0515—Speed Controls
- Group 0520—Intake System
- Group 0530—External Exhaust System
- Group 0560—External Fuel Supply System

SECTION 07—Damper Drive

- Group 0752—Elements

SECTION 09—Steering System

- Group 0930—Secondary Steering
- Group 0960—Hydraulic System

SECTION 10—Service Brakes

- Group 1011—Active Elements
- Group 1015—Controls Linkage
- Group 1060—Hydraulic System

SECTION 11—Park Brake

- Group 1111—Active Elements
- Group 1160—Hydraulic System

SECTION 16—Electrical System

- Group 1671—Batteries, Support and Cables
- Group 1672—Alternator, Regulator and Charging System Wiring
- Group 1673—Lighting System
- Group 1674—Wiring Harness and Switches
- Group 1676—Instruments and Indicators
- Group 1677—Motors and Actuators

SECTION 17—Frame, Chassis, or Supporting Structures

- Group 1740—Frame Installation
- Group 1746—Frame Bottom Guards

SECTION 18—Operator's Station

- Group 1800—Removal and Installation
- Group 1810—Operator Enclosure
- Group 1821—Seat and Seat Belt
- Group 1830—Heating and Air Conditioning

SECTION 19—Sheet Metal and Styling

- Group 1910—Hood or Engine Enclosure
- Group 1921—Grille and Grille Housing

SECTION 20—Safety, Convenience and Miscellaneous

- Group 2003—Fire Extinguisher
- Group 2004—Horn and Warning Devices

SECTION 21—Main Hydraulic System

- Group 2160—Hydraulic System

SECTION 30—Winch

- Group 3000—Removal and Installation
- Group 3015—Controls Linkage
- Group 3025—Input Drive Shafts and U-Joints

SECTION 32—Bulldozers (Stacking and

Continued on next page

All information, illustrations and specifications in this manual are based on the latest information available at the time of publication. The right is reserved to make changes at any time without notice.

COPYRIGHT © 1998
DEERE & COMPANY
Moline, Illinois
All rights reserved
A John Deere ILLUSTRATION® Manual

00
01
02
03
04
05
07
09
10
11

Trailbuilding Blades)

- Group 3201—Blades
- Group 3215—Controls Linkage
- Group 3260—Hydraulic System

SECTION 37—Arch or Boom

- Group 3740—Frames

SECTION 38—Grapple

- Group 3803—Grapple Mechanism
- Group 3815—Control Linkage
- Group 3840—Frames
- Group 3860—Hydraulic System

SECTION 99—Dealer Fabricated Tools

- Group 9900—Dealer Fabricated Tools

Contents

INDX

17

18

19

20

21

30

32

37

38

**Thanks very much for your reading,
Want to get more information,
Please click here, Then get the complete
manual**

JustClickHere 

NOTE:

**If there is no response to click on the link above,
please download the PDF document first, and then
click on it.**

**Have any questions please write to me:
admin@servicemanualperfect.com**

Contents

INDX

17

18

19

20

21

30

32

37

38

Section 00

General Information

Contents

	Page		Page
Group 0001—Safety Information			
Handle Fluids Safely—Avoid Fires	00-0001-1	Winch—6000 Series	00-0002-37
Prevent Battery Explosions	00-0001-1	640G Skidder Capacities	00-0002-38
Prepare for Emergencies	00-0001-1	648G Grapple Skidder	00-0002-40
Prevent Acid Burns	00-0001-2	Grapple Head Specifications	00-0002-44
Handle Chemical Products Safely	00-0001-3	648G Grapple Skidder Engine and System Specifications	00-0002-45
Avoid High-Pressure Fluids	00-0001-3	648G Grapple Skidder Other Information	00-0002-48
Park Machine Safely	00-0001-4	Winch—4000 Series	00-0002-50
Support Machine Properly	00-0001-4	648G Grapple Skidder Capacities	00-0002-52
Wear Protective Clothing	00-0001-4	740G Skidder	00-0002-54
Work in Clean Area	00-0001-5	740G Skidder Engine and System Specifications	00-0002-57
Service Machines Safely	00-0001-5	740G Skidder Other Information	00-0002-60
Work in Ventilated Area	00-0001-5	Winch—6000 Series	00-0002-61
Illuminate Work Area Safely	00-0001-5	740G Skidder Capacities	00-0002-62
Replace Safety Signs	00-0001-6	748G Grapple Skidder	00-0002-64
Use Proper Lifting Equipment	00-0001-6	Grapple Head Specifications	00-0002-67
Remove Paint Before Welding or Heating	00-0001-6	748G Grapple Skidder Engine and System Specifications	00-0002-68
Avoid Heating Near Pressurized Fluid Lines	00-0001-7	748G Grapple Skidder Other Information	00-0002-71
Keep ROPS Installed Properly	00-0001-7	Winch—6000 Series	00-0002-72
Service Tires Safely	00-0001-8	748G Grapple Skidder Capacities	00-0002-73
Avoid Harmful Asbestos Dust	00-0001-8	Group 0003—Torque Values	
Practice Safe Maintenance	00-0001-9	Specifications	00-0003-1
Use Proper Tools	00-0001-9	Hardware Torque Specifications	00-0003-1
Dispose of Waste Properly	00-0001-10	Keeping ROPS Installed Properly	00-0003-1
Live With Safety	00-0001-10	Tighten Upper Frame Pivot Pin	00-0003-2
Group 0002—General Specifications			
540G Skidder	00-0002-2	Metric Bolt and Cap Screw Torque Values	00-0003-3
540G Skidder Engine and System Specifications	00-0002-6	Unified Inch Bolt and Cap Screw Torque Values	00-0003-4
540G Skidder Other Information	00-0002-9	Additional Metric Cap Screw Torque Values	00-0003-5
Winch—4000 Series	00-0002-10	Check Oil Lines and Fittings	00-0003-6
540G Skidder Capacities	00-0002-12	Service Recommendations for 37° Flare and 30° Cone Seat Connectors	00-0003-7
548G Grapple Skidder	00-0002-14	Service Recommendations for O-Ring Boss Fittings	00-0003-8
Single Function Grapple Specifications	00-0002-17	Service Recommendations for Flat Face O-Ring Seal Fittings	00-0003-10
548G Grapple Skidder Engine and System Specifications	00-0002-18	Service Recommendations for Metric Series Four Bolt Flange Fitting	00-0003-11
548G Grapple Skidder Other Information	00-0002-21		
Winch—4000 Series	00-0002-23		
548G Grapple Skidder Capacities	00-0002-25		
640G Skidder	00-0002-26		
640G Skidder Engine and System Specifications	00-0002-30		
640G Skidder Other Information	00-0002-33		
Winch—4000 Series	00-0002-34		

Continued on next page

Page

Service Recommendations for Inch Series
Four Bolt Flange Fittings00-0003-12

Group 0004—Fuels and Lubricants

Specifications00-0004-1
Diesel Fuel00-0004-1
Low Sulfur Diesel Fuel Conditioner00-0004-2
Handling and Storing Diesel Fuel00-0004-2
Do Not Use Galvanized Containers00-0004-3
Fuel Tank00-0004-3
Diesel Engine Oil00-0004-4
Transmission Hydraulic System, Park
Brake, Differential, Hand Pump and Winch
Oils00-0004-5
Grease00-0004-6
Lubricant Storage00-0004-6
Alternative and Synthetic Lubricants00-0004-7
Mixing of Lubricants00-0004-7
Diesel Engine Coolant00-0004-8

Handle Fluids Safely—Avoid Fires

When you work around fuel, do not smoke or work near heaters or other fire hazards.

Store flammable fluids away from fire hazards. Do not incinerate or puncture pressurized containers.

Make sure machine is clean of trash, grease, and debris.

Do not store oily rags; they can ignite and burn spontaneously.



TS227 -JUN-23AUG88

DX,FLAME -19-04JUN90-1/1

Prevent Battery Explosions

Keep sparks, lighted matches, and open flame away from the top of battery. Battery gas can explode.

Never check battery charge by placing a metal object across the posts. Use a voltmeter or hydrometer.

Do not charge a frozen battery; it may explode. Warm battery to 16°C (60°F).



TS204 -JUN-23AUG88

Specification

Charge Battery—Minimum
Temperature 16°C (60°F)

DX,SPARKS -19-03MAR93-1/1

Prepare for Emergencies

Be prepared if a fire starts.

Keep a first aid kit and fire extinguisher handy.

Keep emergency numbers for doctors, ambulance service, hospital, and fire department near your telephone.

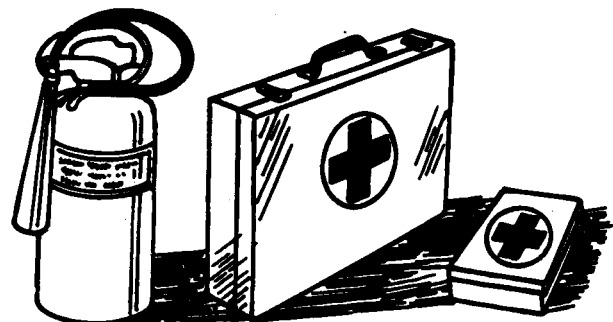

TS291 -JUN-23AUG88

DX,FIRE2 -19-03MAR93-1/1

00
0001
2

Prevent Acid Burns

Sulfuric acid in battery electrolyte is poisonous. It is strong enough to burn skin, eat holes in clothing, and cause blindness if splashed into eyes.

Avoid the hazard by:

1. Filling batteries in a well-ventilated area.
2. Wearing eye protection and rubber gloves.
3. Avoiding breathing fumes when electrolyte is added.
4. Avoiding spilling or dripping electrolyte.
5. Use proper jump start procedure.

If you spill acid on yourself:

1. Flush your skin with water.
2. Apply baking soda or lime to help neutralize the acid.
3. Flush your eyes with water for 15—30 minutes. Get medical attention immediately.

If acid is swallowed:

1. Do not induce vomiting.
2. Drink large amounts of water or milk, but do not exceed 2 L (2 quarts).
3. Get medical attention immediately.

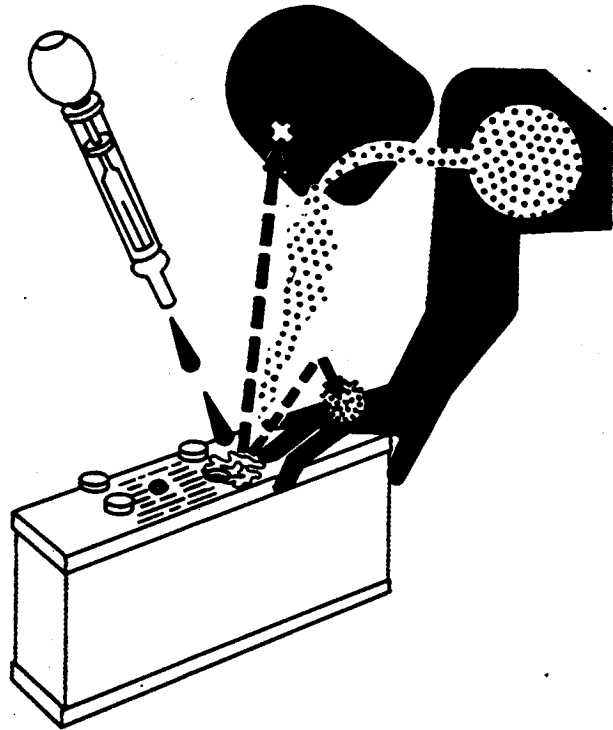

TS203 -UN-23AUG88

DX,POISON -19-21APR93-1/1

Handle Chemical Products Safely

Direct exposure to hazardous chemicals can cause serious injury. Potentially hazardous chemicals used with your machine include such items as lubricants, coolants, paints, and adhesives.

A Material Safety Data Sheet (MSDS) provides specific details on chemical products: physical and health hazards, safety procedures, and emergency response techniques.

Check the MSDS before you start any job using a hazardous chemical. That way you will know exactly what the risks are and how to do the job safely. Then follow procedures and recommended equipment.

See your authorized dealer for MSDS's on chemical products used with your machine.

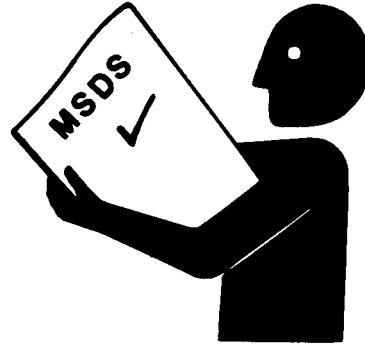

T51132 -UN-26NOV90

TX,05,DH2500 -19-02OCT92-1/1

Avoid High-Pressure Fluids

Escaping fluid under pressure can penetrate the skin causing serious injury.

Avoid the hazard by relieving pressure before disconnecting hydraulic or other lines. Tighten all connections before applying pressure.

Search for leaks with a piece of cardboard. Protect hands and body from high pressure fluids.

If an accident occurs, see a doctor immediately. Any fluid injected into the skin must be surgically removed within a few hours or gangrene may result. Doctors unfamiliar with this type of injury should reference a knowledgeable medical source. Such information is available from Deere & Company Medical Department in Moline, Illinois, U.S.A.

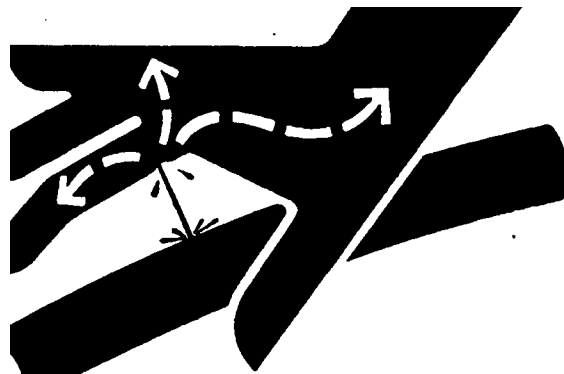

X9811 -UN-23AUG88

DX,FLUID -19-03MAR93-1/1

Park Machine Safely

Before working on the machine:

- Lower all equipment to the ground.
- Stop the engine and remove the key.
- Disconnect the battery ground strap.
- Hang a "DO NOT OPERATE" tag in operator station.

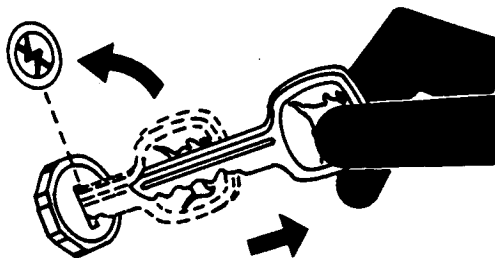

TS230 -UN-24MAY89

DX,PARK -19-04JUN90-1/1

Support Machine Properly

Always lower the attachment or implement to the ground before you work on the machine. If you must work on a lifted machine or attachment, securely support the machine or attachment.

Do not support the machine on cinder blocks, hollow tiles, or props that may crumble under continuous load. Do not work under a machine that is supported solely by a jack. Follow recommended procedures in this manual.

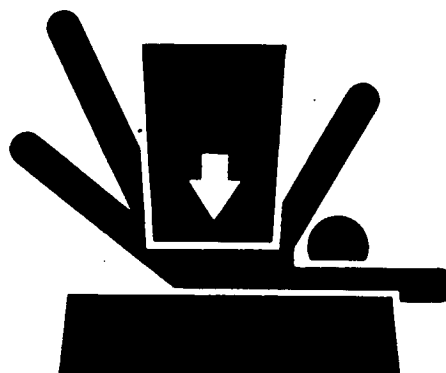

TS229 -UN-23AUG88

DX,LOWER -19-04JUN90-1/1

Wear Protective Clothing

Wear close fitting clothing and safety equipment appropriate to the job.

Prolonged exposure to loud noise can cause impairment or loss of hearing.

Wear a suitable hearing protective device such as earmuffs or earplugs to protect against objectionable or uncomfortable loud noises.

Operating equipment safely requires the full attention of the operator. Do not wear radio or music headphones while operating machine.

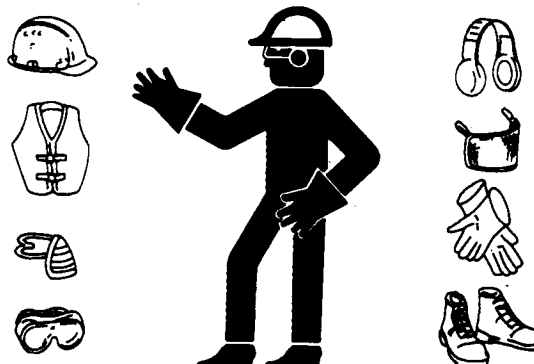

TS206 -UN-23AUG88

DX,WEAR -19-10SEP90-1/1

Work in Clean Area

Before starting a job:

- Clean work area and machine.
- Make sure you have all necessary tools to do your job.
- Have the right parts on hand.
- Read all instructions thoroughly; do not attempt shortcuts.

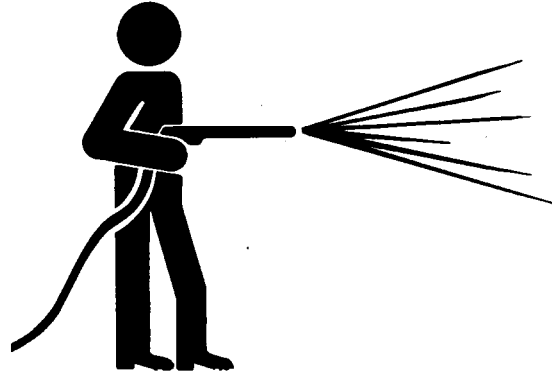

DX,CLEAN -19-04JUN90-1/1

T6642EJ -JUN-18OCT88

Service Machines Safely

Tie long hair behind your head. Do not wear a necktie, scarf, loose clothing, or necklace when you work near machine tools or moving parts. If these items were to get caught, severe injury could result.

Remove rings and other jewelry to prevent electrical shorts and entanglement in moving parts.

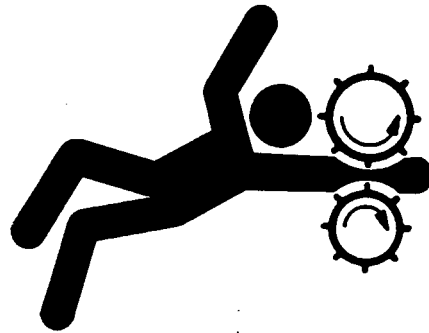

DX,LOOSE -19-04JUN90-1/1

TS228 -JUN-23AUG88

Work in Ventilated Area

Engine exhaust fumes can cause sickness or death. If it is necessary to run an engine in an enclosed area, remove the exhaust fumes from the area with an exhaust pipe extension.

If you do not have an exhaust pipe extension, open the doors and get outside air into the area.

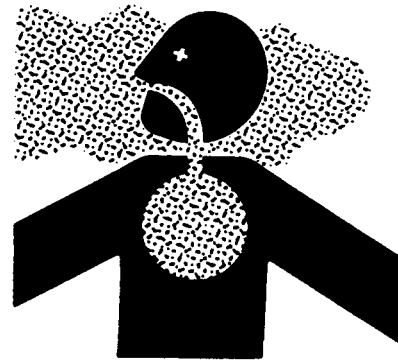

DX,AIR -19-04JUN90-1/1

TS220 -JUN-23AUG88

Illuminate Work Area Safely

Illuminate your work area adequately but safely. Use a portable safety light for working inside or under the machine. Make sure the bulb is enclosed by a wire cage. The hot filament of an accidentally broken bulb can ignite spilled fuel or oil.

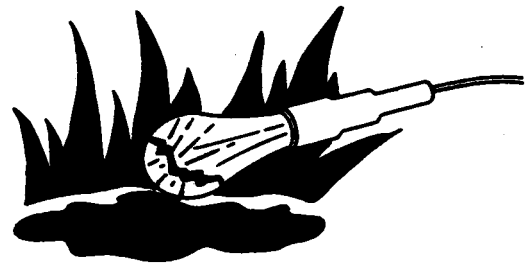

DX,LIGHT -19-04JUN90-1/1

TS223 -JUN-23AUG88

00
0001
6

Replace Safety Signs

Replace missing or damaged safety signs. See the machine operator's manual for correct safety sign placement.



TS201 -UN-23AUG88

DX,SIGNS1 -19-04JUN90-1/1

Use Proper Lifting Equipment

Lifting heavy components incorrectly can cause severe injury or machine damage.

Follow recommended procedure for removal and installation of components in the manual.

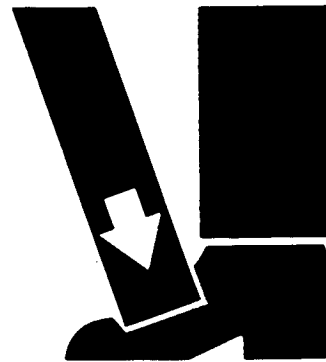

TS226 -UN-23AUG88

DX,LIFT -19-04JUN90-1/1

Remove Paint Before Welding or Heating

Avoid potentially toxic fumes and dust.

Hazardous fumes can be generated when paint is heated by welding, soldering, or using a torch.

Do all work outside or in a well ventilated area. Dispose of paint and solvent properly.

Remove paint before welding or heating:

- If you sand or grind paint, avoid breathing the dust. Wear an approved respirator.
- If you use solvent or paint stripper, remove stripper with soap and water before welding. Remove solvent or paint stripper containers and other flammable material from area. Allow fumes to disperse at least 15 minutes before welding or heating.

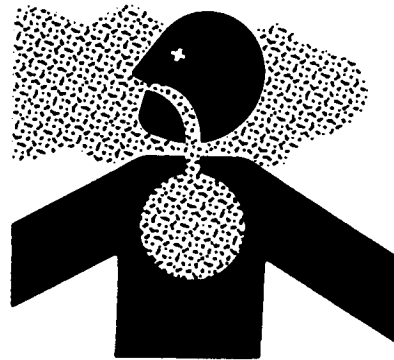

TS220 -UN-23AUG88

DX,PAINT -19-03MAR93-1/1

Avoid Heating Near Pressurized Fluid Lines

Flammable spray can be generated by heating near pressurized fluid lines, resulting in severe burns to yourself and bystanders. Do not heat by welding, soldering, or using a torch near pressurized fluid lines or other flammable materials. Pressurized lines can be accidentally cut when heat goes beyond the immediate flame area.



TS953 -JUN-15MAY90

DX.TORCH -19-03MAR93-1/1

Keep ROPS Installed Properly

Make certain all parts are reinstalled correctly if the roll-over protective structure (ROPS) is loosened or removed for any reason. Tighten mounting bolts to proper torque.

The protection offered by ROPS will be impaired if ROPS is subjected to structural damage, is involved in an overturn incident, or is in any way altered by welding, bending, drilling, or cutting. A damaged ROPS should be replaced, not reused.

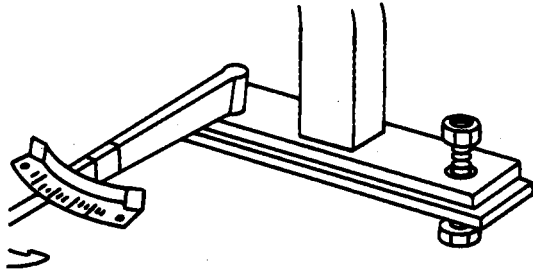

TS212 -JUN-23AUG88

DX.ROPS3 -19-03MAR93-1/1

00
0001
8

Service Tires Safely

Explosive separation of a tire and rim parts can cause serious injury or death.

Do not attempt to mount a tire unless you have the proper equipment and experience to perform the job.

Always maintain the correct tire pressure. Do not inflate the tires above the recommended pressure. Never weld or heat a wheel and tire assembly. The heat can cause an increase in air pressure resulting in a tire explosion. Welding can structurally weaken or deform the wheel.

When inflating tires, use a clip-on chuck and extension hose long enough to allow you to stand to one side and NOT in front of or over the tire assembly. Use a safety cage if available.

Check wheels for low pressure, cuts, bubbles, damaged rims or missing lug bolts and nuts.

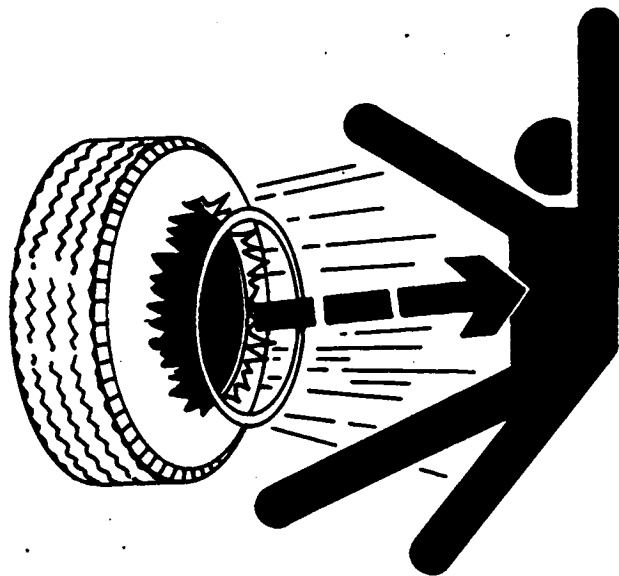

TS211 -UN-23AUG88

DX,RIM -19-24AUG90-1/1

Avoid Harmful Asbestos Dust

Avoid breathing dust that may be generated when handling components containing asbestos fibers. Inhaled asbestos fibers may cause lung cancer.

Components in products that may contain asbestos fibers are brake pads, brake band and lining assemblies, clutch plates, and some gaskets. The asbestos used in these components is usually found in a resin or sealed in some way. Normal handling is not hazardous as long as airborne dust containing asbestos is not generated.

Avoid creating dust. Never use compressed air for cleaning. Avoid brushing or grinding material containing asbestos. When servicing, wear an approved respirator. A special vacuum cleaner is recommended to clean asbestos. If not available, apply a mist of oil or water on the material containing asbestos.

Keep bystanders away from the area.

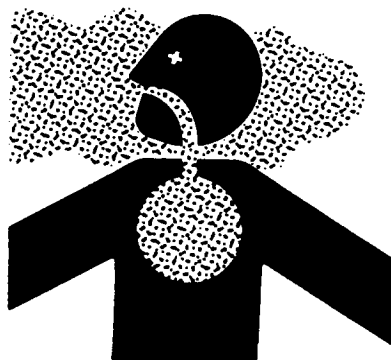

TS220 -UN-23AUG88

DX,DUST -19-15MAR91-1/1

Practice Safe Maintenance

Understand service procedure before doing work. Keep area clean and dry.

Never lubricate, service, or adjust machine while it is moving. Keep hands, feet, and clothing from power-driven parts. Disengage all power and operate controls to relieve pressure. Lower equipment to the ground. Stop the engine. Remove the key. Allow machine to cool.

Securely support any machine elements that must be raised for service work.

Keep all parts in good condition and properly installed. Fix damage immediately. Replace worn or broken parts. Remove any buildup of grease, oil, or debris.

Disconnect battery ground cable (—) before making adjustments on electrical systems or welding on machine.



TS218 -UN-23AUG88

DX,SERV -19-03MAR93-1/1

Use Proper Tools

Use tools appropriate to the work. Makeshift tools and procedures can create safety hazards.

Use power tools only to loosen threaded parts and fasteners.

For loosening and tightening hardware, use the correct size tools. DO NOT use U.S. measurement tools on metric fasteners. Avoid bodily injury caused by slipping wrenches.

Use only service parts meeting John Deere specifications.



TS779 -UN-08NOV/89

DX,REPAIR -19-04JUN90-1/1

00
0001
10

Dispose of Waste Properly

Improperly disposing of waste can threaten the environment and ecology. Potentially harmful waste used with your machine include such items as oil, fuel, coolant, brake fluid, filters, and batteries.

Use leakproof containers when draining fluids. Do not use food or beverage containers that may mislead someone into drinking from them.

Do not pour waste onto the ground, down a drain, or into any water source.

Air conditioning refrigerants escaping into the air can damage the Earth's atmosphere. Government regulations may require a certified air conditioning service center to recover and recycle used air conditioning refrigerants.

Inquire on the proper way to recycle or dispose of waste from your local environmental or recycling center, or from your authorized dealer.

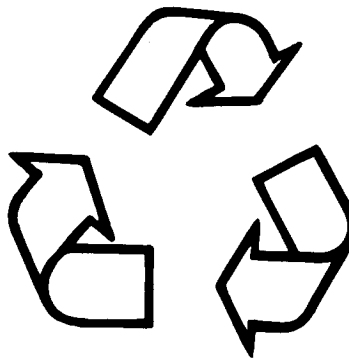

TS1133 -UN-26NOV90

TX,05,DH2502 -19-26AUG92-1/1

Live With Safety

Before returning machine to customer, make sure machine is functioning properly, especially the safety systems. Install all guards and shields.



TS231 -19-07OCT88

DX,LIVE -19-25SEP92-1/1

00
0002
2
540G Skidder

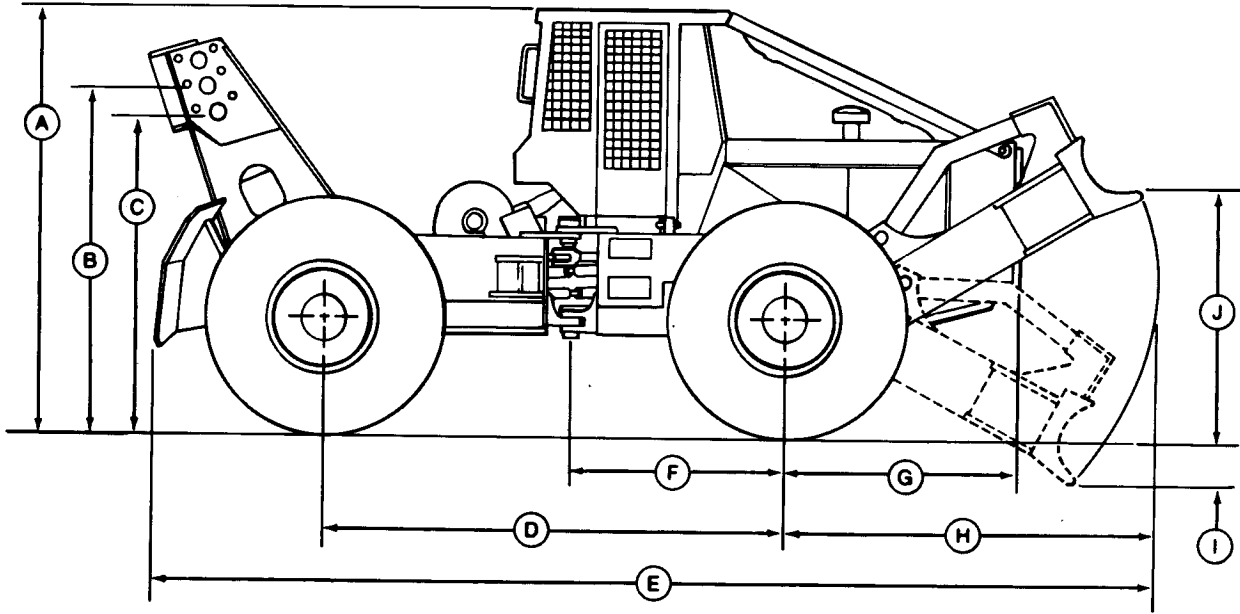

T7409BX -JUN-05DEC90

NOTE: Specifications and design subject to change without notice. Whenever applicable, specifications are in accordance with SAE Standards unless otherwise noted, these

specifications are based on a standard machine with 23.1L—26 10 PR LS2 tires, adjustable log arch, full fuel tank and 79 kg (175 lb) operator.

Item	Measurement	Specification
A—Overall Height	Height	3010 mm (9 ft 11 in.)
A—Overall Height with Factory Installed Air Conditioning	Height	3229 mm (10 ft 7 in.)
B—Main Fairlead Roller Height	Height	2110 mm (6 ft 11.1 in.)
C—Auxiliary Position Fairlead Roller Height	Height	1925 mm (6 ft 3.8 in.)
D—Wheelbase	Distance	2920 mm (9 ft 7 in.)
E—Overall Length	Length	6084 mm (19 ft 11.5 in.)
F—Front Axle to Articulation Joint	Distance	1575 mm (5 ft 2 in.)

Continued on next page

CED,OUO1040,162 -19-16JUN98-1/4

General Specifications

00
0002
3

Item	Measurement	Specification
G—Front Axle to Front of Machine	Distance	1507 mm (4 ft 11 in.)
H—Front Axle to Blade Cutting Edge Arc	Distance	2112 mm (6 ft 11.1 in.)
I—Maximum Blade Dig Depth Below Ground	Depth	288 mm (11.3 in.)
J—Maximum Blade Lift Above Ground	Distance	1220 mm (3 ft 11.6 in.)

Continued on next page

CED,OUO1040,162 -19-16JUN98-2/4

General Specifications

00
0002
4

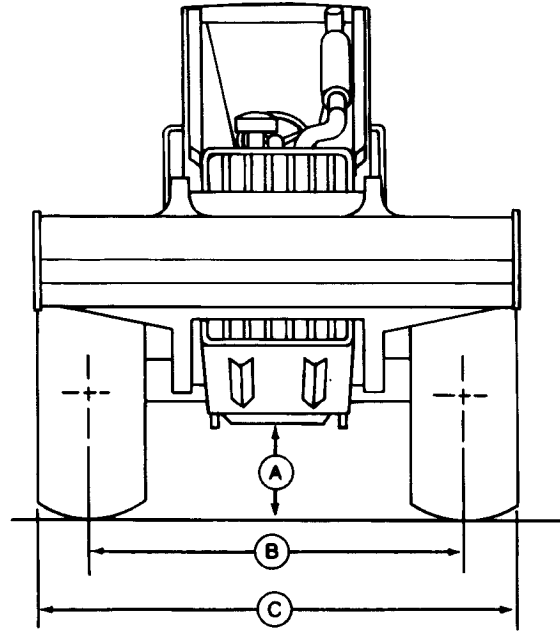

T7417AA -UN-05DEC90

Item	Measurement	Specification
Tire Size: 23.1—26		
A—Ground Clearance	Clearance	498 mm (19.6 in.)
B—Wheel Tread	Distance	2.21 m (7 ft 3 in.)
C—Overall Width	Width	2.79 m (9 ft 2 in.)
Tire Size: 28L—26		
A—Ground Clearance	Clearance	514 mm (20.2 in.)
B—Wheel Tread	Distance	2.29 m (7 ft 6 in.)
C—Overall Width	Width	3.0 m (9 ft 10 in.)
Tire Size: 23.1—26 (Narrow Gauge)		
A—Ground Clearance	Clearance	498 mm (19.6 in.)
B—Wheel Tread	Distance	2.06 m (6 ft 9 in.)

Continued on next page

CED,OUO1040,162 -19-16JUN98-3/4