

SERVICE REPAIR

MANUAL

Hyster F004 (S70XM, S80XM, S100XM, S80XM BCS, S100XM BCS, S120XMS, S100XM PRS) Forklift

HYSTER

MASTS

DESCRIPTION AND REPAIRS

E3.50-5.50XL₃ (E70-120XL₃) [C098];
S3.50-5.50XM (S70-120XM) [E004, F004];
H3.50-5.50XM (H70-120XM) [K005, L005]

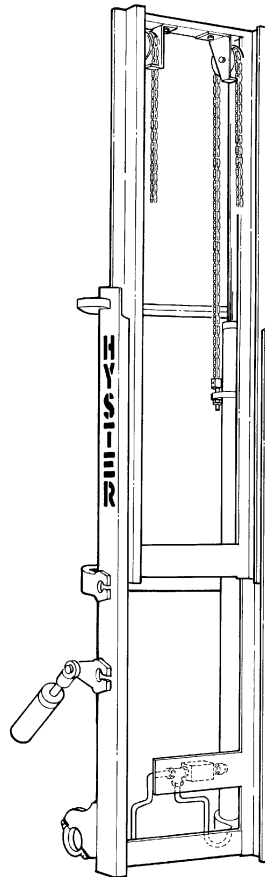

HM170066

HYSTER

SAFETY PRECAUTIONS

MAINTENANCE AND REPAIR

- When lifting parts or assemblies, make sure all slings, chains, or cables are correctly fastened, and that the load being lifted is balanced. Make sure the crane, cables, and chains have the capacity to support the weight of the load.
- Do not lift heavy parts by hand, use a lifting mechanism.
- Wear safety glasses.
- **DISCONNECT THE BATTERY CONNECTOR** before doing any maintenance or repair on electric lift trucks.
- Disconnect the battery ground cable on internal combustion lift trucks.
- Always use correct blocks to prevent the unit from rolling or falling. See **HOW TO PUT THE LIFT TRUCK ON BLOCKS** in the **Operating Manual** or the **Periodic Maintenance** section.
- Keep the unit clean and the working area clean and orderly.
- Use the correct tools for the job.
- Keep the tools clean and in good condition.
- Always use **HYSTER APPROVED** parts when making repairs. Replacement parts must meet or exceed the specifications of the original equipment manufacturer.
- Make sure all nuts, bolts, snap rings, and other fastening devices are removed before using force to remove parts.
- Always fasten a **DO NOT OPERATE** tag to the controls of the unit when making repairs, or if the unit needs repairs.
- Be sure to follow the **WARNING** and **CAUTION** notes in the instructions.
- Gasoline, Liquid Petroleum Gas (LPG), Compressed Natural Gas (CNG), and Diesel fuel are flammable. Be sure to follow the necessary safety precautions when handling these fuels and when working on these fuel systems.
- Batteries generate flammable gas when they are being charged. Keep fire and sparks away from the area. Make sure the area is well ventilated.

NOTE: The following symbols and words indicate safety information in this manual:



WARNING

Indicates a condition that can cause immediate death or injury!



CAUTION

Indicates a condition that can cause property damage!

TABLE OF CONTENTS

General	1
Description and Operation	1
Carriages	1
Two-Stage Mast With Limited Free-Lift	1
Two-Stage Mast With Full Free-Lift	2
Three-Stage Mast With Full Free-Lift	3
Safety Procedures When Working Near Mast	5
Fork Replacement	7
Remove	8
Install	8
Carriage Repair	9
Remove	9
Sideshift Carriage Repair	10
Remove	10
Disassemble	10
Assemble	10
Install	11
Two-Stage Mast With Limited Free-Lift Repair	12
Remove - H3.50-5.50XM (H70-120XM) Model Lift Trucks	12
Remove - S3.50-5.50XM (S70-120XM) and E3.50-5.50XL ₃ (E70-120XL ₃) Model Lift Trucks	12
Disassemble	12
Clean and Inspect	16
Assemble	17
Install - H3.50-5.50XM (H70-120XM) Lift Truck Models	18
Install - S3.50-5.50XM (S70-120XM) and E3.50-5.50XL ₃ (E70-120XL ₃) Lift Truck Models	20
Two-Stage Mast With Full Free-Lift Repair	22
Remove	22
Disassemble	22
Clean and Inspect	24
Assemble	24
Install	24
Three-Stage Mast With Full Free-Lift Repair	26
Remove	26
Disassemble	26
Clean and Inspect	29
Assemble	29
Install	31
Mast Operation Check	35
Lift and Tilt System Leak Check	35
Lift System	35
Tilt System	36
Tilt Cylinder Stroke and Backward Tilt Angle Adjustment	37
Lift Chain Adjustments	38
Mast Adjustments	41
Carriage Adjustment	43
Troubleshooting	43

**Thanks very much for your reading,
Want to get more information,
Please click here, Then get the complete
manual**

JustClickHere 

NOTE:

**If there is no response to click on the link above,
please download the PDF document first, and then
click on it.**

**Have any questions please write to me:
admin@servicemanualperfect.com**

TABLE OF CONTENTS (Continued)

This section is for the following models:

E3.50-5.50XL₃ (E70-120XL₃) [C098];
S3.50-5.50XM (S70-120XM) [E004, F004];
H3.50-5.50XM (H70-120XM) [K005, L005]

General

This section contains the description, operation, and repair procedures for the masts. Information on sideshift carriage is also included in the section.

Description and Operation

Vertical frames of a mast are called weldments. See Figure 1. Channels, load rollers, and crossmembers are parts of the weldments. Channels on each side of the weldment are support members of the mast and tracks for load rollers. While lifting and lowering a load, large forces are put on the mast assembly. Load rollers reduce the friction between the channels when the weldments move vertically.

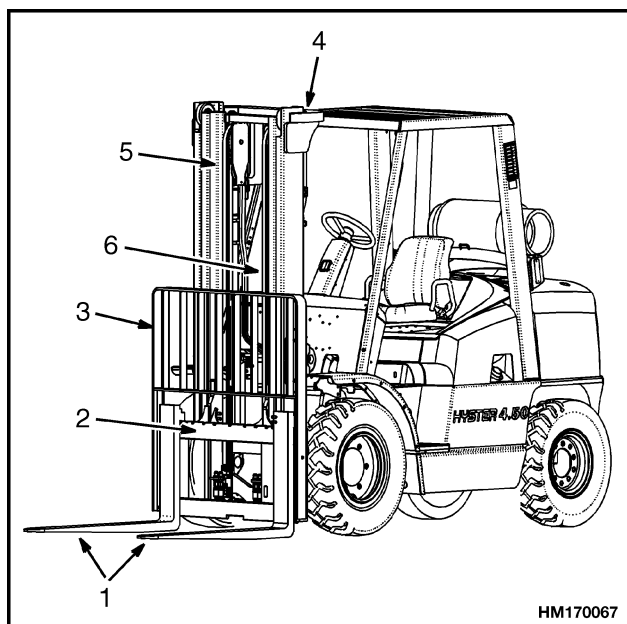

- | | |
|----------------------------|-------------------|
| 1. FORKS | 4. OUTER WELDMENT |
| 2. CARRIAGE | 5. INNER WELDMENT |
| 3. LOAD BACKREST EXTENSION | 6. LIFT CYLINDER |

Figure 1. Mast Components

The mast can tilt forward and backward. Tilt cylinders are installed between the frame of the lift truck and outer weldment of the mast. For H3.50-5.50XM (H70-120XM) lift trucks, the pivot mounts at the bottom of the outer weldment connect the mast to the

lift truck. During tilt operation, the mast rotates on pivot pins in the frame.

For S3.50-5.50XM and E3.50-5.50XL₃ (E70-120XL₃) model lift trucks, mast mounting hangers are attached to the drive axle and connect the mast to the lift truck. During tilt operation, the mast rotates on the drive axle.

CARRIAGES

The carriage is a separate section that moves on load rollers within vertical channels of the inner weldment. Forks or other types of load handling equipment are attached to the carriage. A load backrest extension is installed on the carriage.

A sideshift carriage permits the operator to hydraulically change the lateral position of the load handling device on the carriage.

TWO-STAGE MAST WITH LIMITED FREE-LIFT

The two-stage mast with limited free-lift (LFL) has two weldments, an outer weldment and an inner weldment. See Figure 2. Outer weldment is connected to the lift truck by pivot mounts and tilt cylinders. The top of the outer weldment and the base of the inner weldment have one load roller on each side. These load rollers travel along channels of the weldments. The angle of the load rollers permits them to control the forces from the front, back, and sides of the mast. Shims on the load rollers control lateral clearance between weldments and load rollers. Strip bearings are installed at the top of each side of the outer weldment. Strip bearings keep correct clearance (forward and backward) between outer weldment and inner weldments.

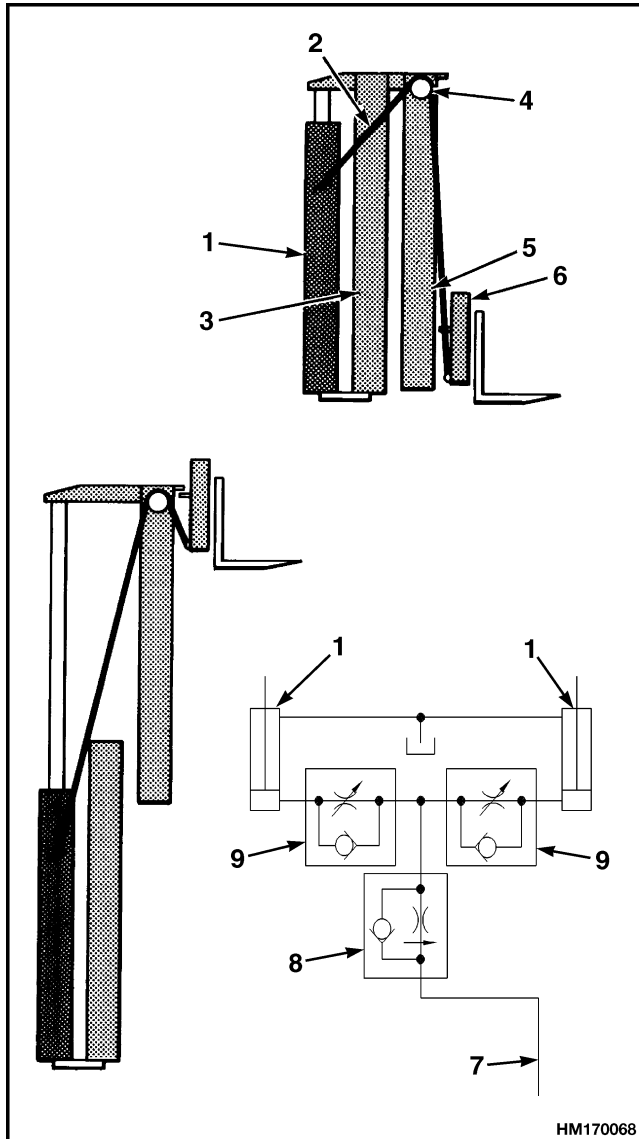

- | | |
|----------------------|------------------------------------|
| 1. LIFT CYLINDER (2) | 7. FROM MAIN CONTROL VALVE |
| 2. LIFT CHAIN | 8. EXTERNAL LOWERING CONTROL VALVE |
| 3. OUTER WELDMENT | 9. INTERNAL LOWERING CONTROL VALVE |
| 4. CHAIN SHEAVE | |
| 5. INNER WELDMENT | |
| 6. CARRIAGE | |

Figure 2. Two-Stage Mast With Limited Free-Lift

The two-stage mast with limited free-lift has two single-stage lift cylinders. Lift cylinders are installed at the back of the outer weldment. The base of each lift cylinder is held on a mount at the bottom of the outer weldment by brackets. The top of each lift cylinder (cylinder rod) fits into a guide at the top of the inner

weldment. A clamp holds the top of the lift cylinder in position on the outer weldment. Operation of lift cylinders extends and retracts the inner weldment.

Two lift chains control the movement of the carriage. Chains are fastened to mounts near the top of the outer weldment. The chains go up and over chain sheaves on inner weldment and then connect to the carriage. When lift cylinders extend, lift chains transfer the force from lift cylinders to the carriage.

When lift cylinders retract, weight of the load, carriage, and inner weldment push oil from the lift cylinders. Oil flows from lift cylinders, through lowering control valves, main control valve, and then to the hydraulic tank.

TWO-STAGE MAST WITH FULL FREE-LIFT

The two-stage mast with full free-lift (FFL) has an inner weldment, an outer weldment, and three single-stage lift cylinders. See Figure 3. It is called a free-lift mast because the carriage can travel to the top of the inner weldment without increasing mast height. The free-lift mast has load roller and strip bearing arrangements similar to the two-stage mast with limited free-lift.

Two main lift cylinders are installed at the back of the outer weldment. The base of each lift cylinder sits in a mount at the bottom of the outer weldment. The hydraulic fitting for each lift cylinder goes through a hole in the mount. The top of each lift cylinder (cylinder rod) fits into guides at the top of the inner weldment.

Free-lift cylinder is installed in the inner weldment. Main lift cylinder on the right side of the mast and the free-lift cylinder each have an internal lowering control valve. A single external lowering control valve is connected by tubing to all lift cylinders. Two chain sheaves are installed on the cylinder rod of the free-lift cylinder. Lift chains are connected to a mount behind the free-lift cylinder. The chains then go over the sheaves and are connected to the carriage.

Three lift cylinders are connected by hoses and tubing. To extend the mast, oil from main control valve flows to all lift cylinders at the same time. Free-lift cylinder raises first because it lifts the least amount of weight. Free-lift cylinder raises the carriage to the top of the inner weldment. After the free-lift cylinder reaches the end of its stroke, main lift cylinders begin to extend and raise the inner weldment.

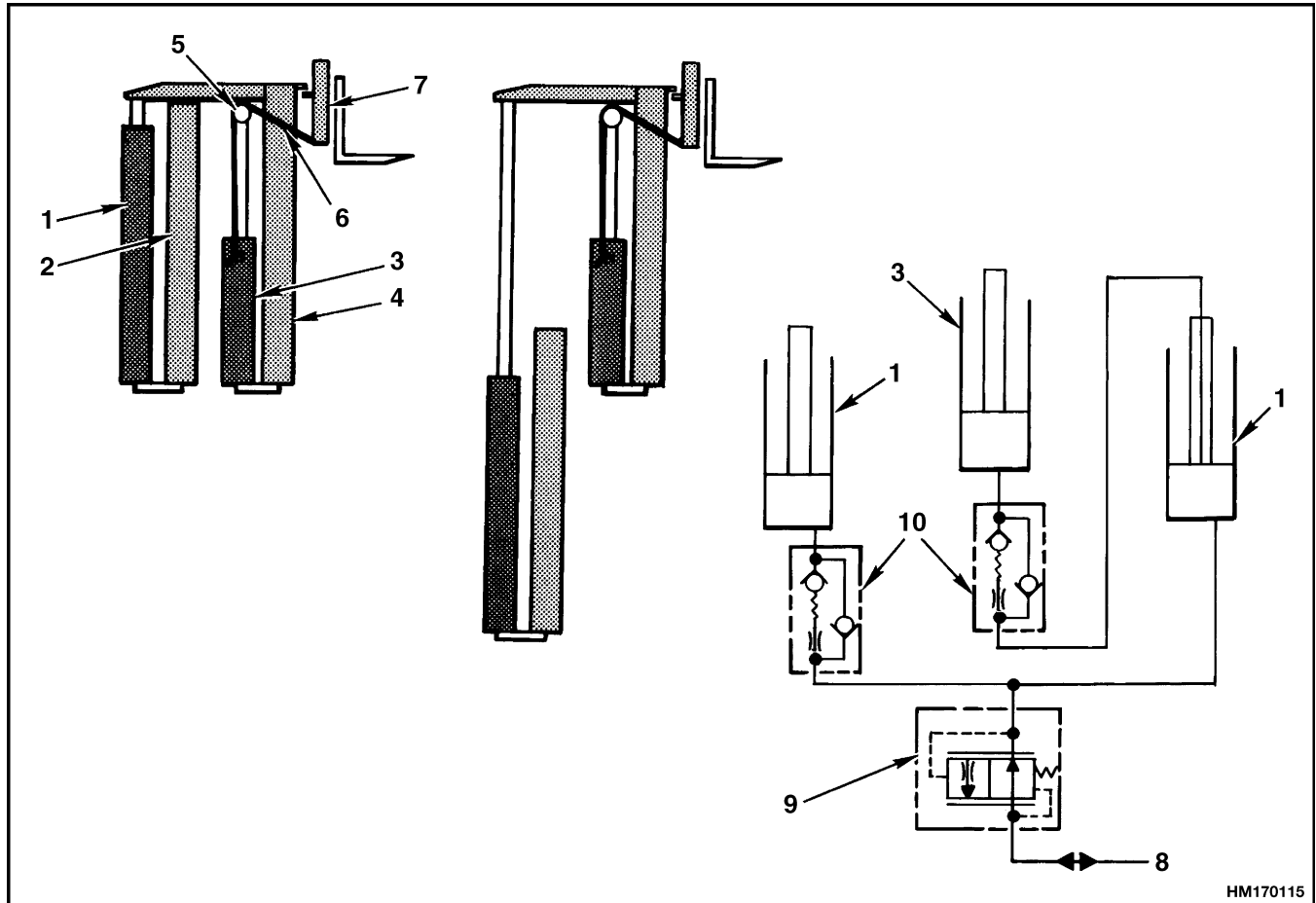

1. MAIN LIFT CYLINDER (2)
2. OUTER WELDMENT
3. FREE-LIFT CYLINDER
4. INNER WELDMENT
5. CHAIN SHEAVE

6. LIFT CHAIN
7. CARRIAGE
8. FROM MAIN CONTROL VALVE
9. EXTERNAL LOWERING CONTROL VALVE
10. INTERNAL LOWERING CONTROL VALVE

Figure 3. Two-Stage Mast With Full Free-Lift

During lowering, main lift cylinders lower first because they have a greater load. After main lift cylinders have retracted, free-lift cylinder lowers. All oil from the lift cylinders flows through the lowering control valves to the hydraulic tank.

THREE-STAGE MAST WITH FULL FREE-LIFT

The three-stage mast with full free-lift (FFL) has an outer, an intermediate, and an inner weldment. See Figure 4. Three single-stage lift cylinders are used

to raise the carriage and extend weldments. Weldments are telescopic and have load roller and strip bearing arrangements similar to the two-stage mast. Two main lift cylinders are installed at the back of the outer weldment. The base of each lift cylinder is held on a mount at the bottom of the outer weldment by brackets. The top of each main lift cylinder (cylinder rod) fits into a guide at the top of the intermediate weldment. A clamp holds the top of the lift cylinder in position on the outer weldment. The free-lift cylinder is installed in the inner weldment and held in position by two clamps.

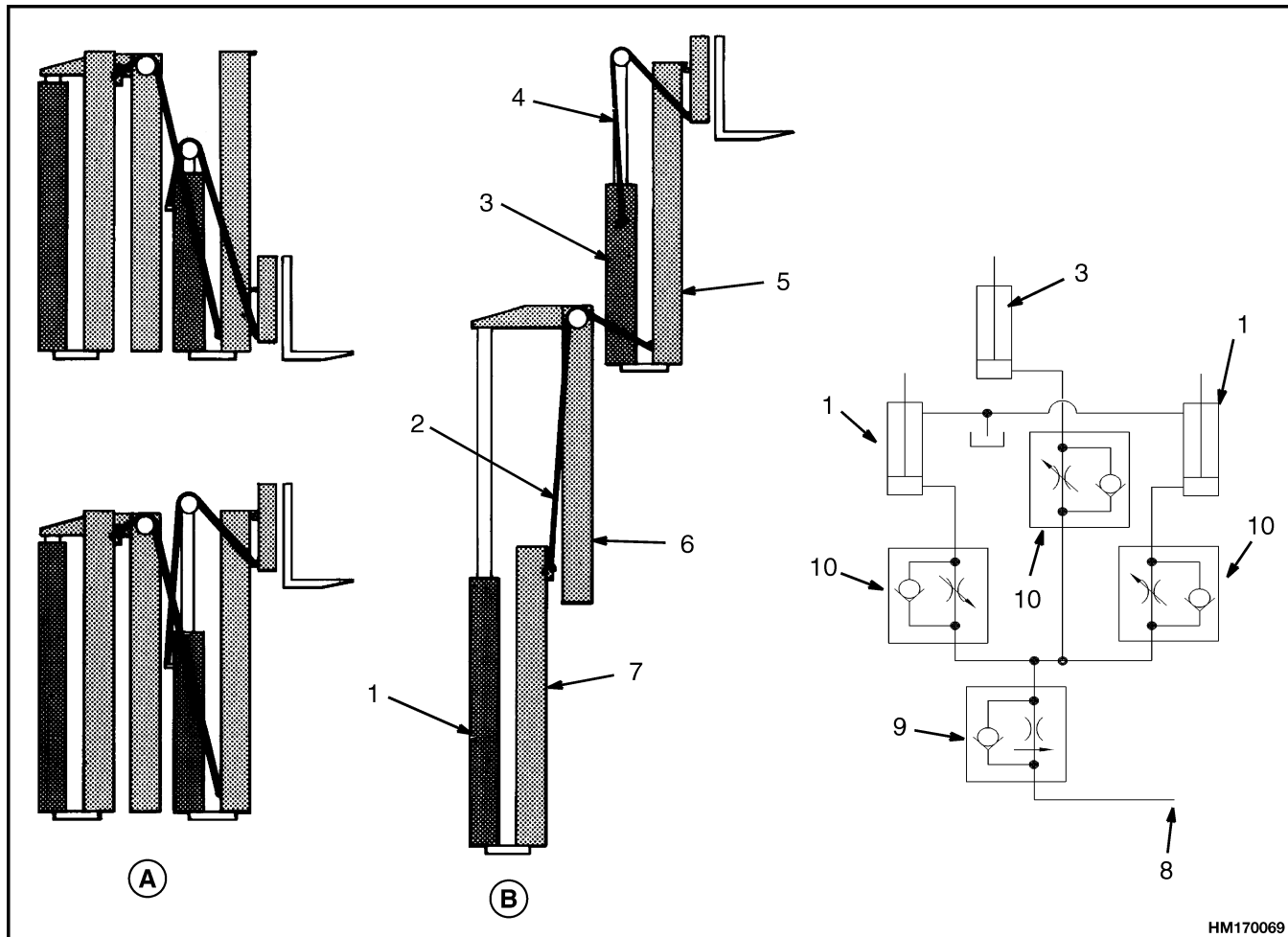

HM170069

A. PHASE 1

1. MAIN LIFT CYLINDER (2)
2. OUTER LIFT CHAIN
3. FREE-LIFT CYLINDER
4. INNER LIFT CHAIN
5. INNER WELDMENT

B. PHASE 2

6. INTERMEDIATE WELDMENT
7. OUTER WELDMENT
8. FROM MAIN CONTROL VALVE
9. EXTERNAL LOWERING CONTROL VALVE
10. INTERNAL LOWERING CONTROL VALVE

Figure 4. Three-Stage Mast With Full Free-Lift

Two main lift chains fasten at one end near the top of the outer weldment. The lift chains then go over sheaves at the top of the intermediate weldment and fasten at the bottom of the inner weldment. Free-lift chains are connected to a mount behind the free-lift cylinder. Chains then go over the sheaves and connect to the carriage.

Three lift cylinders are connected by hoses. To extend mast, oil from main control valve flows to all cylinders at the same time. Free-lift cylinder raises first because it lifts the least amount of weight. Free-lift

cylinder raises the carriage to the top of the inner weldment. After free-lift cylinder reaches the end of its stroke, the main lift cylinders begin to extend. As main lift cylinders extend intermediate weldment, inner weldment is extended by lift chains.

During lowering, main lift cylinders lower first because they have a greater load. After the main lift cylinders have retracted, free-lift cylinder lowers. All oil from lift cylinders flows through the lowering control valves to the hydraulic tank.

Safety Procedures When Working Near Mast

The following procedures **MUST** be used when inspecting or working near the mast. Additional precautions and procedures can be required when repairing or removing the mast.



WARNING

Mast parts are heavy and can move. Distances between parts are small. Serious injury or death can result if part of the body is hit by parts of the mast or the carriage.

- **Never put any part of the body into or under the mast or carriage unless all parts are completely lowered or a safety chain is installed. Also make sure that the power is off and the key is removed. Put a DO NOT OPERATE tag in the operator's compartment. Disconnect the battery on electric lift trucks and put a tag or lock on the battery connector.**
- **Be careful of the forks. When the mast is raised, the forks can be at a height to cause an injury.**
- **DO NOT climb on the mast or lift truck at any time. Use a ladder or personnel lift to work on the mast.**
- **DO NOT use blocks to support the mast weldments nor to restrain their movement.**
- **Mast repairs require disassembly and removal of parts and can require removal of the mast or carriage. Follow the repair procedures in the correct Service Manual for the mast.**

WHEN WORKING NEAR THE MAST ALWAYS:

- **Lower the mast and carriage completely. Push the lift/lower control lever forward and make sure there is no movement in the mast. Make sure that all parts of the mast that move are fully lowered.**

OR

- **If parts of the mast must be in a raised position, install a safety chain to restrain the moving parts of the mast. Connect moving parts to a part that does not move. Follow these procedures:**

NOTE: Apply the parking brake. After lowering or restraining the mast, shut off the power and remove the key. Put a **DO NOT OPERATE** tag in the operator's compartment. Disconnect the battery on electric lift trucks and put a tag or lock on the battery connector.

1. Put mast in a vertical position.
2. Raise mast to align the bottom crossmember of the weldment that moves in the outer weldment with a crossmember on the outer weldment. On the two-stage and free-lift mast, the moving part is the inner weldment. On the three-stage mast, it is the intermediate weldment. See Figure 5.
3. Use a 3/8 inch minimum safety chain with a hook to fasten the crossmembers together so the movable member cannot lower. Put hook on back side of the mast. Make sure hook is completely engaged with a link in the chain. Make sure safety chain does not touch lift chains or chain sheaves, tubes, hoses, fittings, or other parts on the mast.
4. Lower the mast until there is tension in the safety chain and the free-lift cylinder (free-lift, three-stage, and four-stage masts only) is completely retracted. If running, stop the engine. Apply the parking brake. Install a **DO NOT REMOVE** tag on the safety chain(s).
5. Install another safety chain (3/8 inch minimum) between the top or bottom crossmember of the carriage and a crossmember on the outer weldment.

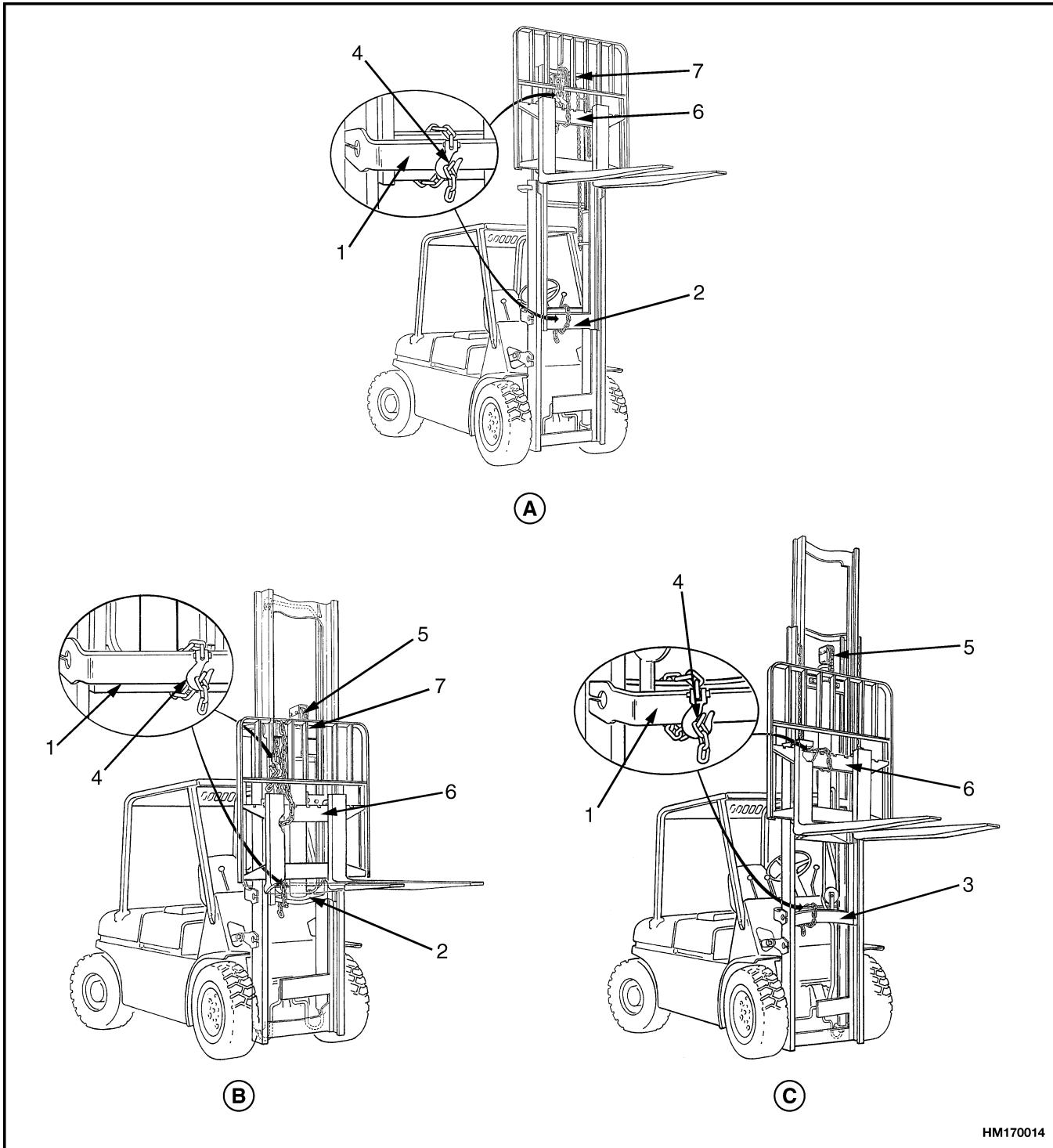

HM170014

A. TWO-STAGE LFL MAST

B. TWO-STAGE FFL MAST

C. THREE-STAGE FFL MAST

- 1. OUTER WELDMENT
- 2. INNER WELDMENT
- 3. INTERMEDIATE WELDMENT

- 4. HOOK
- 5. FREE-LIFT CYLINDER
- 6. CROSSMEMBER

- 7. CROSSMEMBER

Figure 5. Two-Stage LFL, Two-Stage FFL, and Three-Stage FFL Masts

Fork Replacement

The identification of a fork describes how the fork is connected to the carriage. The series of lift trucks

covered in this section have hook type forks. See Figure 6.

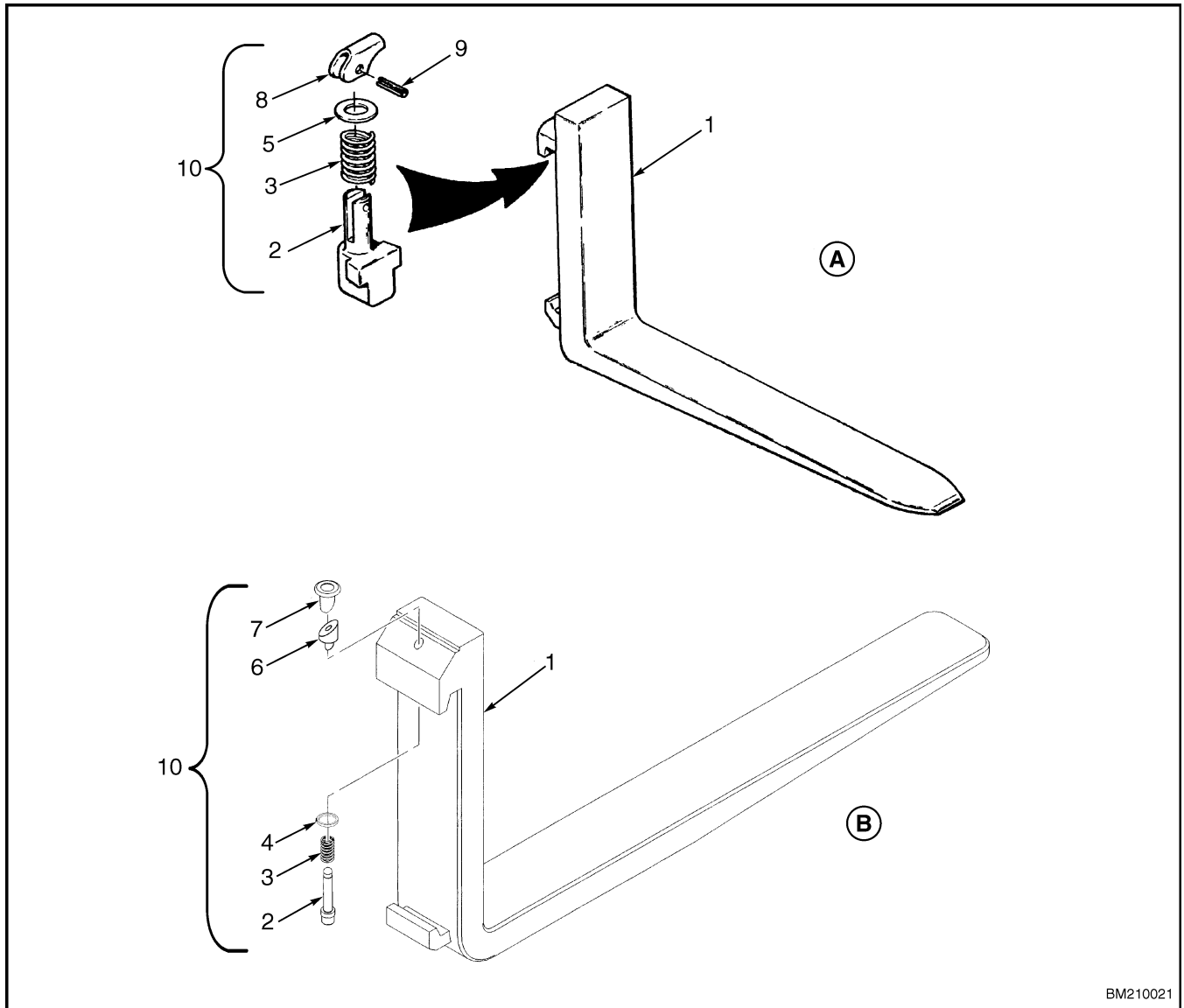

BM210021

A. OLD STYLE LOCK PIN ASSEMBLY

B. NEW STYLE PIN ASSEMBLY

- 1. FORK
- 2. LOCK PIN
- 3. SPRING
- 4. WASHER
- 5. WASHER

- 6. WEDGE
- 7. KNOB
- 8. LEVER
- 9. COTTER PIN
- 10. LOCK PIN ASSEMBLY

Figure 6. Fork Lock Pin Assembly

The forks can be connected to the carriage by one of two types of hooks and lock pins. See Figure 6. These lock pins are installed through the top fork hooks and fit into slots in the top carriage bar. Separate the forks as much as possible for maximum support of the load. Hook forks will slide along the carriage bars to adjust for the load to be lifted. Raise the lock pin in each fork to slide the fork on the carriage bar. Make sure the lock pin is engaged in the carriage bar to lock the fork in position after the width adjustment is made.

A fork can be removed from the carriage for replacement of the fork or other maintenance.

REMOVE



WARNING

Do not try to move a fork without a lifting device. Each fork for these lift trucks can weigh 66 to 183 kg (145 to 403 lb).

1. Slide fork to fork removal notch on carriage. See Figure 7.

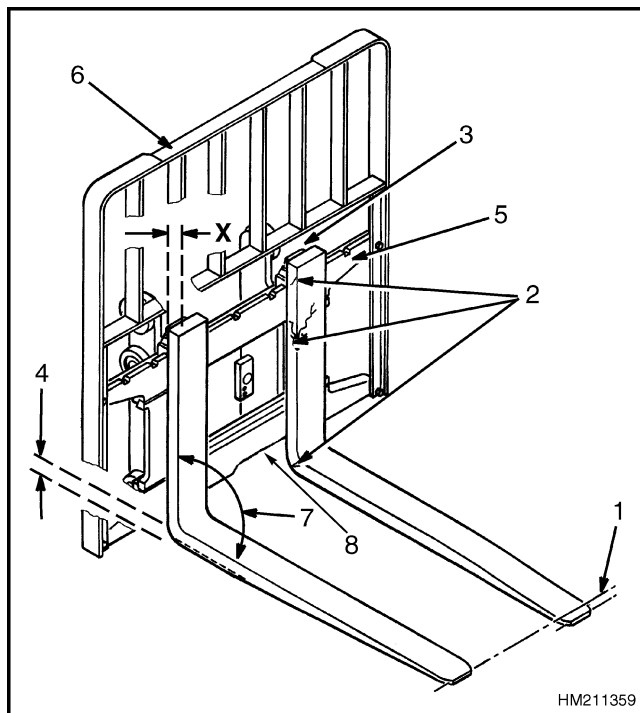
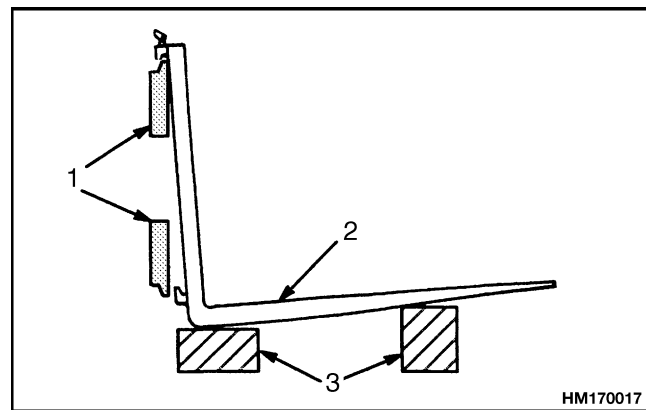

Figure 7. Forks Check

Legend for Figure 7

1. TIP ALIGNMENT (MUST BE WITHIN 3% OF FORK LENGTH)
2. CRACKS
3. LATCH DAMAGE
4. HEEL OF FORK (MUST BE 90% OF DIMENSION "X")
5. CARRIAGE
6. LOAD BACKREST EXTENSION
7. MAXIMUM ANGLE 93°
8. FORK REMOVAL NOTCH

2. Lower fork onto blocks so that bottom hook of fork moves through fork removal notch. See Figure 8.



1. CARRIAGE FORKS
2. HOOK FORK
3. BLOCKS

Figure 8. Hook Fork Removal

3. Lower carriage further so that top hook of fork is disengaged from the top carriage bar.
4. Move carriage away from fork, or use a lifting device to move fork away from carriage.

INSTALL

1. Move fork and carriage so that top hook on fork can engage the upper carriage bar.
2. Raise carriage to move lower hook through the fork removal notch.
3. Slide fork on the carriage so that both upper and lower hooks engage the carriage.
4. Engage lock pin with a notch in the upper carriage bar.

Carriage Repair

REMOVE

WARNING

Do not work under a raised carriage. Lower the carriage or use a chain or blocks to prevent the carriage and inner weldment from lowering.

NOTE: If the mast is equipped with a sideshift carriage, see the paragraphs under Sideshift Carriage Repair.

1. Put weight on the forks so carriage has stability and will not fall when it is disconnected from the mast.

2. Lower carriage and forks on blocks so lift chains become loose.

WARNING

When disconnecting the lift chains, keep control of the ends. Use wire to temporarily connect the ends of the lift chains to the mast. This procedure will prevent the lift chains from falling and causing an injury or damage.

3. Remove pin from each chain anchor at the carriage. Disconnect lift chains from carriage. See Figure 9.

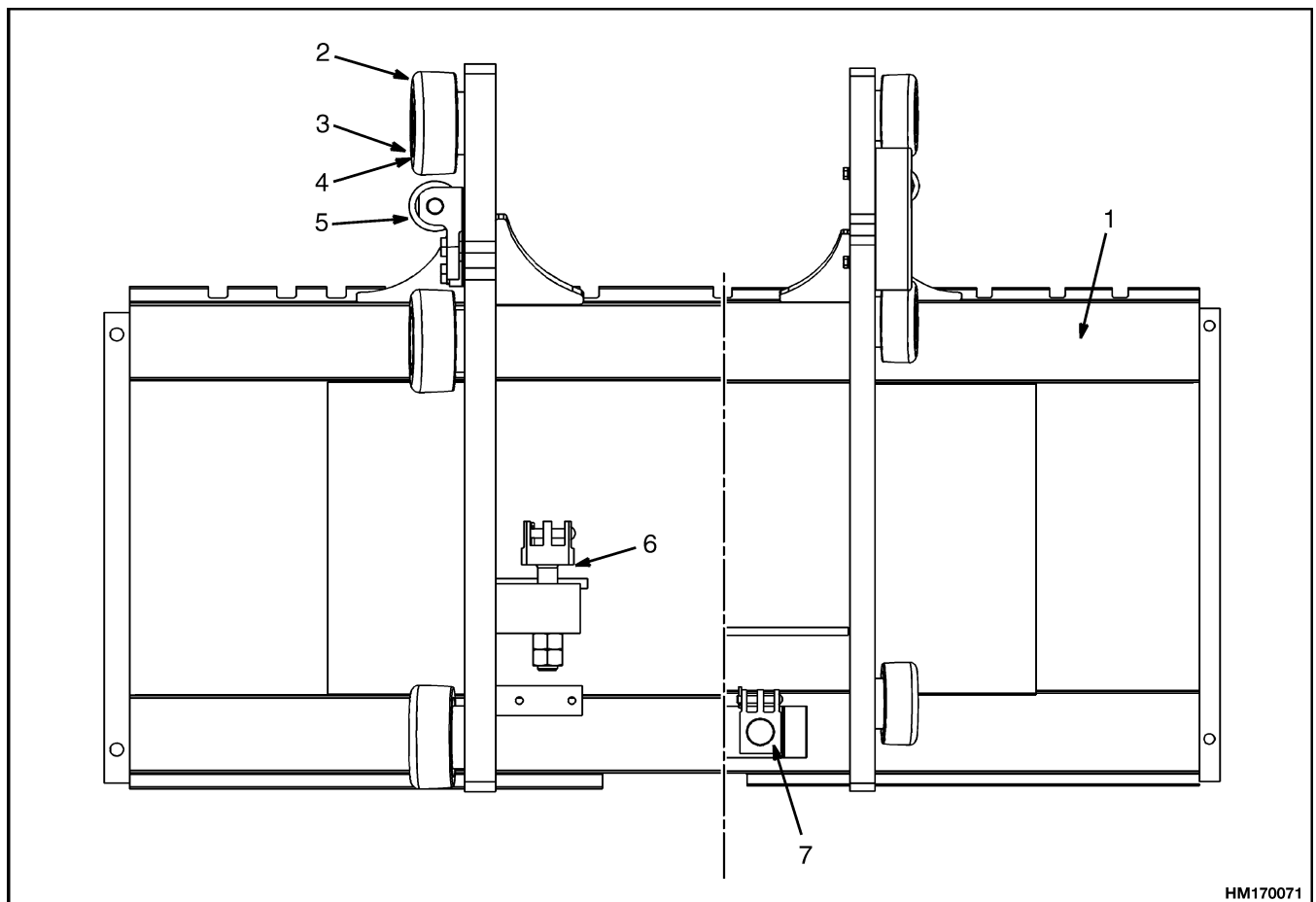

1. CARRIAGE
2. LOAD ROLLER
3. SHIMS
4. SNAP RING

5. SIDE ROLLER
6. CHAIN ANCHOR (TWO-STAGE MAST)
7. CHAIN ANCHOR (FREE-LIFT AND THREE-STAGE MAST)

Figure 9. Carriage

**WARNING**

Make sure the carriage has stability and will not fall over when the inner weldment is raised above the load rollers of the carriage.

4. Use lift cylinders to raise inner weldment until it is above the load rollers of the carriage. If the hydraulic system cannot be used, connect a lifting device to the top of the inner weldment. Carefully raise inner weldment until it is above the load rollers of the carriage.

5. Move lift truck from carriage. Connect a lifting device to the carriage. Make sure carriage is stable. Remove load backrest and forks. Put carriage on floor so that load rollers are up.
6. If any of the load rollers must be replaced, make a note of the arrangement of the shims.
7. Reverse this procedure for carriage installation.

Sideshift Carriage Repair

REMOVE

1. Relieve hydraulic pressure to the sideshift cylinder by moving sideshift lever in both directions several times. See Figure 10.
2. Disconnect hydraulic lines from sideshift cylinder. Put caps and plugs on open lines and cylinder ports.
3. Remove sideshift carriage as described below:
 - a. Put weight on the forks so carriage is stable and will not fall when it is disconnected from the mast.
 - b. Lower carriage and forks on blocks so lift chains become loose.

**WARNING**

When disconnecting the lift chains, keep control of the ends. Use wire to temporarily connect the ends of the lift chains to the mast. This procedure will prevent the lift chains from falling and causing an injury or damage.

- c. Remove pin from each chain anchor at the carriage. Disconnect lift chains from carriage. See Figure 9.

DISASSEMBLE

1. Remove capscrews from lower hooks and remove the lower hooks. See Figure 10.

2. Lift the mobile frame from the bottom and rotate it forward to free it from the fixed frame.
3. Remove upper and lower pads from the fixed frame.
4. If damaged, remove grease fittings from the fixed frame.
5. Remove sideshift cylinder rods from each end of the cylinder body.
6. Remove snap rings from each end of the cylinder body and remove rod scrapers, rod bushings, and seals from cylinder body.

ASSEMBLE

1. Lubricate with clean hydraulic oil and install seals, rod bushings, and rod scrapers into the cylinder body and secure with snap rings. See Figure 10.
2. Install cylinder rods into each end of the cylinder body.
3. Install grease fittings into the fixed frame if removed.
4. Install upper and lower pads onto the fixed frame.

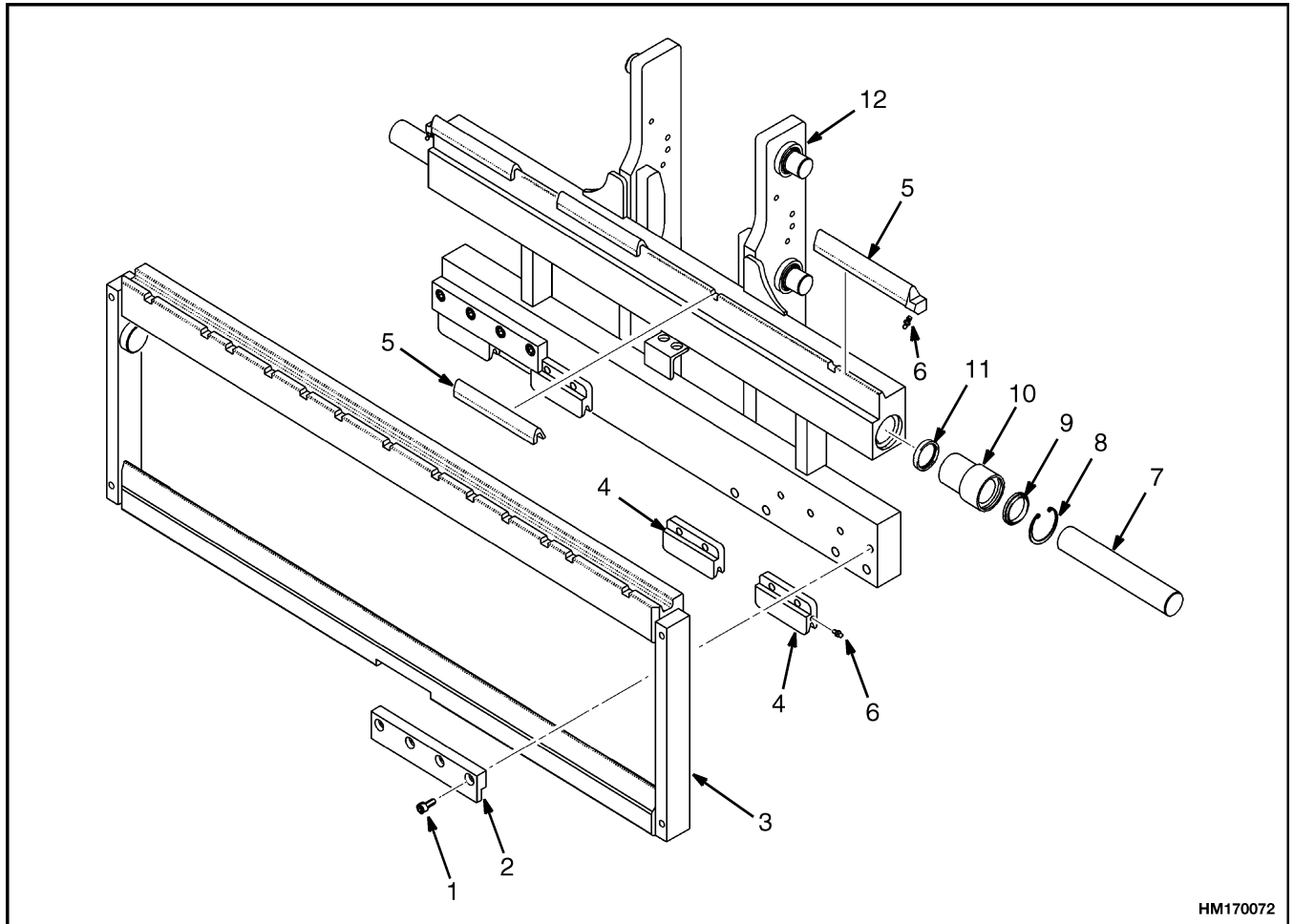

HM170072

- | | |
|--------------------|-----------------|
| 1. CAPSCREWS | 7. CYLINDER ROD |
| 2. LOWER HOOK | 8. SNAP RING |
| 3. MOBILE FRAME | 9. ROD SCRAPER |
| 4. LOWER PADS | 10. ROD BUSHING |
| 5. UPPER PADS | 11. SEAL |
| 6. GREASE FITTINGS | 12. FIXED FRAME |

Figure 10. Sideshift Carriage

5. Install the mobile frame onto the fixed frame by hooking it at the top of the fixed frame first and lowering it to the bottom.
6. Install lower hooks and capscrews. Tighten the capscrews to 78 N•m (58 lbf ft).

INSTALL

1. To install the sideshift carriage onto the truck, reverse the procedure for removal as described in section Carriage Repair.
2. Remove protective caps and plugs from hydraulic lines and cylinder ports. Connect lines to the sideshift cylinder.

Two-Stage Mast With Limited Free-Lift Repair

REMOVE - H3.50-5.50XM (H70-120XM) MODEL LIFT TRUCKS

1. Fully lower the inner weldment. If mast must be disassembled, remove forks and carriage as described in sections Fork Replacement and Carriage Repair.
2. Connect a lifting device to all top crossmembers of the mast weldments (see Figure 5.) Make sure lifting device will hold the weight of the mast. Raise lifting device so the mast has stability.
3. Remove anchor pins for tilt cylinders at the mast (see Figure 26.) Use the hydraulic system to retract tilt cylinders.
4. Disconnect hydraulic line for the mast at the lowering control valve (see Figure 11). Disconnect breather lines for the cylinders. Put plugs in the open lines.
5. Remove capscrews for the pivot pins at the frame of the lift truck (see Figure 26.) Use a lifting device to move mast from the lift truck. Put mast in a position so crossmembers are on the floor.

REMOVE - S3.50-5.50XM (S70-120XM) AND E3.50-5.50XL₃ (E70-120XL₃) MODEL LIFT TRUCKS

1. Fully lower inner weldment. If mast must be disassembled, remove forks and carriage as described in sections Fork Replacement and Carriage Repair.
2. Connect a lifting device to all top crossmembers of the mast weldments (see Figure 5.) Make sure lifting device will hold the weight of the mast. Raise lifting device so the mast has stability.
3. Remove tilt pins, tilt pin retainers, anchor pin capscrews, and washers for tilt cylinders at the mast. Use hydraulic system to retract tilt cylinders. See Figure 12.
4. Disconnect hydraulic line for the mast at the lowering control valve. Disconnect breather lines for lift cylinders. Put plugs in open lines. See Figure 13.

5. Remove the four capscrews holding the left and right mast mounting hangers to the drive axle. Use a lifting device to move mast from lift truck. Put mast in a position so the crossmembers are on the floor.

DISASSEMBLE

1. Clean area around hydraulic fittings for the lift cylinders. Disconnect fittings at the lift cylinders and put caps on open lines. See Figure 11 and Figure 13.
2. Remove capscrews, washers, and brackets that mount the bottom of each lift cylinder.
3. Slide inner weldment from outer weldment approximately 30 cm (12 in.) to disengage lift cylinders from inner weldment. Remove lift cylinders from the mounts at the bottom of outer weldment.
4. Slide inner weldment from the bottom of outer weldment approximately 30 cm (12 in.). Remove strip bearings. Remove load rollers from both weldments. Make a note of the shim arrangement. The shim arrangement will be approximately the same during assembly procedures.
5. Slide inner weldment halfway out of the top of outer weldment. Connect a crane to the center of inner weldment. See Figure 14. Slide inner weldment out of the outer weldment until stub shafts are in the notches of the outer weldment. Remove inner weldment from outer weldment.
6. For H3.50-5.50XM (H70-120XM) model lift trucks, remove snap rings and bushings at the mast mounts. See Figure 26.
7. For S3.50-5.50XM (S70-120XM) and E3.50-5.50XL₃ (E70-120XL₃) model lift trucks, remove bushings and plugs at the mast mounting hangers. See Figure 12.
8. Remove and disassemble chain sheaves as necessary for cleaning and repair.

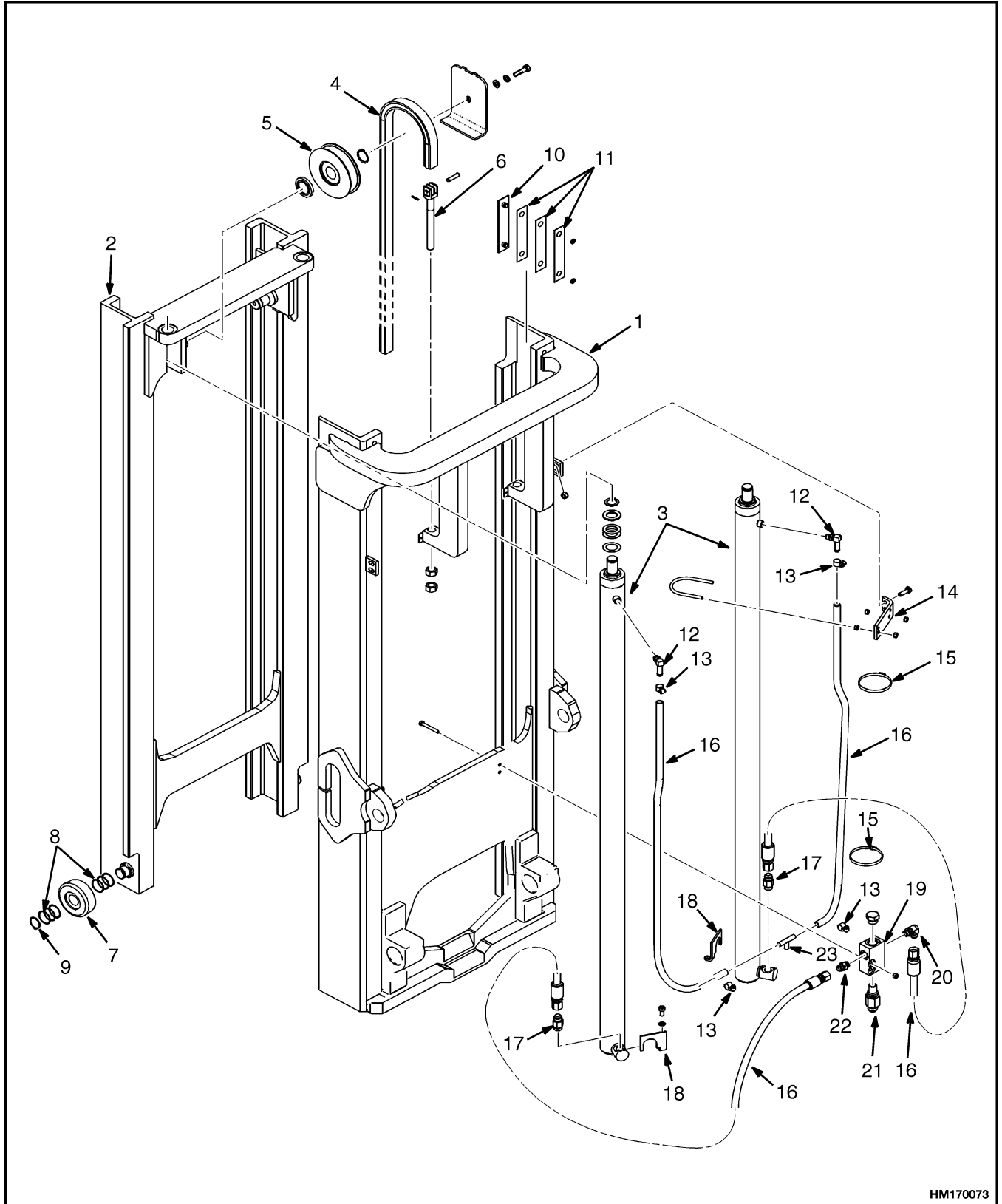

HM170073

Figure 11. Two-Stage Mast With Limited Free-Lift - H3.50-5.50XM (H70-120XM) Model Lift Trucks

Legend for Figure 11

- | | |
|-------------------|----------------------------|
| 1. OUTER WELDMENT | 13. CLAMP |
| 2. INNER WELDMENT | 14. CLAMP |
| 3. LIFT CYLINDER | 15. CLAMP |
| 4. LIFT CHAIN | 16. HOSE |
| 5. CHAIN SHEAVE | 17. VELOCITY FUSE |
| 6. CHAIN ANCHOR | 18. BRACKET |
| 7. LOAD ROLLER | 19. HOUSING |
| 8. SHIMS | 20. FITTING |
| 9. SNAP RING | 21. LOWERING CONTROL VALVE |
| 10. STRIP BEARING | 22. FITTING |
| 11. SHIMS | 23. FITTING |

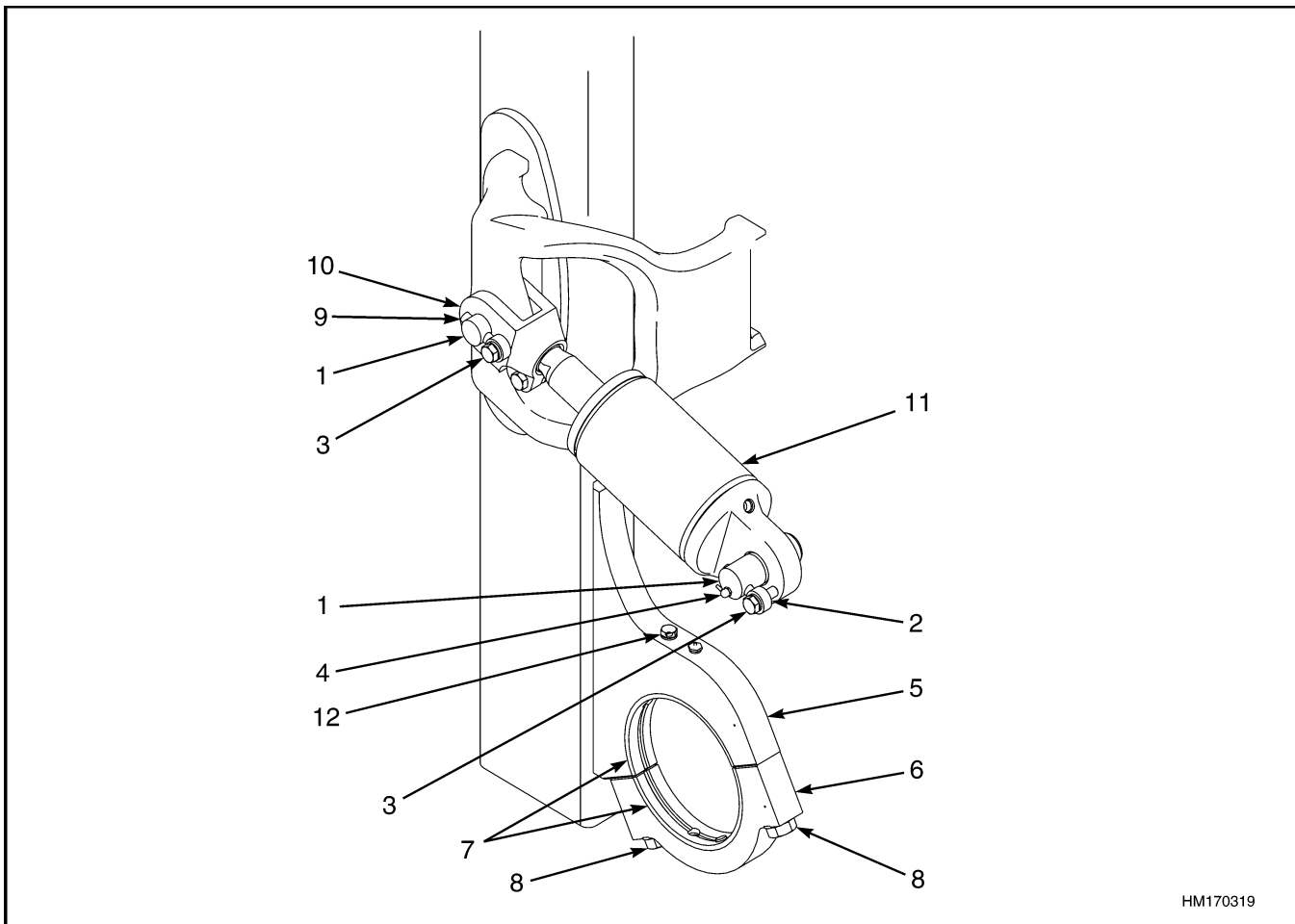

HM170319

- | | | |
|-------------------------|----------------------|----------------------------|
| 1. TILT PIN | 6. MAST MOUNTING CAP | 10. ROD END |
| 2. ANCHOR PIN CAPSCREWS | 7. MAST BUSHING | 11. TILT CYLINDER ASSEMBLY |
| 3. CAPSCREW AND WASHER | 8. MAST MOUNTING | 12. CAPSCREW AND WASHER |
| 4. LUBE FITTINGS | 9. TILT PIN RETAINER | FOR MAIN LIFT CYLINDER |
| 5. MAST MOUNTING HANGER | | RESTRAINT BRACKET |

Figure 12. Mast Mounting and Tilt Cylinder Removal - S3.50-5.50XM (S70-120XM) and E3.50-5.50XL₃ (E70-120XL₃) Model Lift Trucks

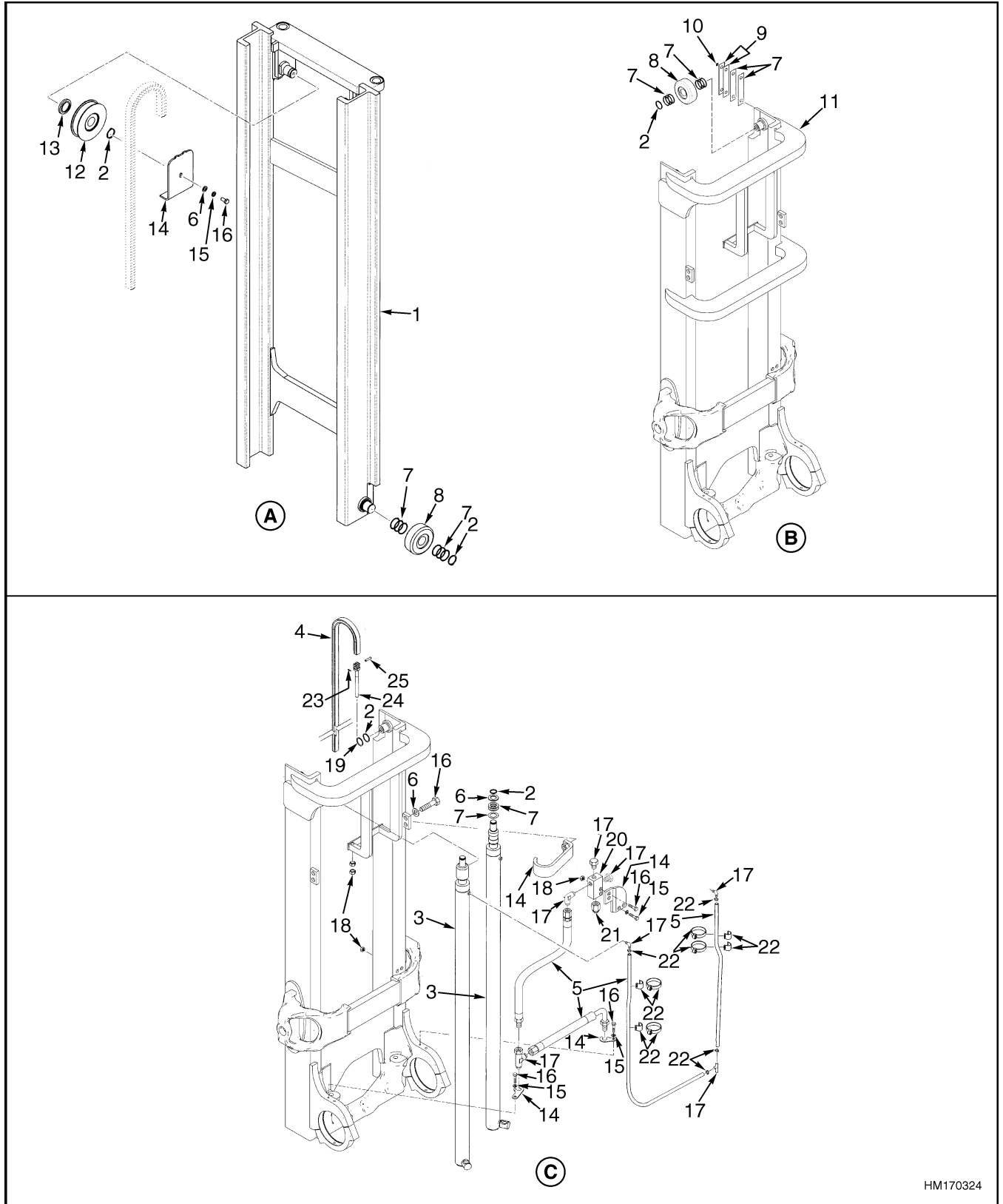

Figure 13. Two-Stage Mast With Limited Free-Lift - S3.50-5.50XM (S70-120XM) and E3.50-5.50XL₃ (E70-120XL₃) Lift Truck Models

HM170324