

**SERVICE REPAIR**

**MANUAL**

Hyster B218 (W40Z) Forklift

***HYSTER***

# **PERIODIC MAINTENANCE**

**W40Z [B218]; W45Z [C215]**

# ***HYSTER***

# SAFETY PRECAUTIONS

## MAINTENANCE AND REPAIR

- When lifting parts or assemblies, make sure all slings, chains, or cables are correctly fastened, and that the load being lifted is balanced. Make sure the crane, cables, and chains have the capacity to support the weight of the load.
- Do not lift heavy parts by hand, use a lifting mechanism.
- Wear safety glasses.
- **DISCONNECT THE BATTERY CONNECTOR** before doing any maintenance or repair on electric lift trucks.
- Disconnect the battery ground cable on internal combustion lift trucks.
- Always use correct blocks to prevent the unit from rolling or falling. See **HOW TO PUT THE LIFT TRUCK ON BLOCKS** in the **Operating Manual** or the **Periodic Maintenance** section.
- Keep the unit clean and the working area clean and orderly.
- Use the correct tools for the job.
- Keep the tools clean and in good condition.
- Always use **HYSTER APPROVED** parts when making repairs. Replacement parts must meet or exceed the specifications of the original equipment manufacturer.
- Make sure all nuts, bolts, snap rings, and other fastening devices are removed before using force to remove parts.
- Always fasten a **DO NOT OPERATE** tag to the controls of the unit when making repairs, or if the unit needs repairs.
- Be sure to follow the **WARNING** and **CAUTION** notes in the instructions.
- Gasoline, Liquid Petroleum Gas (LPG), Compressed Natural Gas (CNG), and Diesel fuel are flammable. Be sure to follow the necessary safety precautions when handling these fuels and when working on these fuel systems.
- Batteries generate flammable gas when they are being charged. Keep fire and sparks away from the area. Make sure the area is well ventilated.

**NOTE:** The following symbols and words indicate safety information in this manual:



### **WARNING**

**Indicates a condition that can cause immediate death or injury!**



### **CAUTION**

**Indicates a condition that can cause property damage!**

## TABLE OF CONTENTS

General .....	1
How to Move a Disabled Truck .....	1
How to Tow the Lift Truck .....	2
How to Put a Lift Truck on Blocks.....	2
How to Raise Drive/Steer Tire .....	2
How to Raise Load Wheels .....	3
Welding Repairs.....	3
Battery Maintenance .....	4
How to Charge the Battery .....	4
Equalizing Charge.....	4
Normal Charge .....	4
Maintenance Free Battery Charger .....	5
Battery Charger (W40Z only) .....	5
How to Change the Battery.....	5
Maintenance Schedule.....	6
Checks and Inspection Procedures .....	6
Hydraulic System.....	7
Lifting Mechanism .....	8
Controls.....	8
Electrical and Battery .....	9
Wheels and Tires.....	9
Recommended Schedule of Maintenance.....	9
Lubrication Instructions.....	15
Every 8 Hours or Daily.....	15
Every 350 Hours or 2 Months .....	15
Check Hydraulic Oil Level.....	15
Every 2000 Hours or 1 Year .....	15
To Fill Hydraulic Tank .....	15

This section is for the following models:

W40Z [B218];  
W45Z [C215]

**"THE  
QUALITY  
KEEPERS"**

**HYSTER  
APPROVED  
PARTS**

**Thanks very much for your reading,  
Want to get more information,  
Please click here, Then get the complete  
manual**

**JustClickHere** 

**NOTE:**

**If there is no response to click on the link above,  
please download the PDF document first, and then  
click on it.**

**Have any questions please write to me:  
[admin@servicemanualperfect.com](mailto:admin@servicemanualperfect.com)**

## General



### WARNING

Do not make repairs or adjustments unless you have both authorization and training. Repairs and adjustments that are not correct can make a dangerous operating condition.



### WARNING

Do not operate a lift truck that needs repairs. Report the need for repairs to your supervisor immediately. If repair is necessary, put a **DO NOT OPERATE** tag on the control handle. Remove the key from the key switch.

This section contains the instructions for periodic maintenance and inspection and a Maintenance Schedule.

The Maintenance Schedule has time intervals for inspection, lubrication, and periodic maintenance. The time intervals are based on a normal operation. A normal operation is considered to be one eight hour shift per day in a relatively clean environment on an improved surface. Multiple shifts, dirty operating conditions, etc., will require a reduction in the recommended time periods in the Maintenance Schedule.

**NOTE:** The front end of the lift truck is the control handle end. Forward travel is movement with the forks trailing. Rear travel is movement in the direction of the forks. The right hand side of the lift truck is to the operator's right hand, facing the truck from the control handle end in the position for operating the controls.

Your Hyster lift truck dealer has the trained personnel and equipment to do a complete program of inspection, lubrication, and maintenance. This complete program will help your lift truck operate better over a longer period of time.

Some users have service personnel and facilities to do the items listed in the Maintenance Schedule. Service Manuals are available from your Hyster lift truck dealer to help users who do their own repairs.

### HOW TO MOVE A DISABLED TRUCK

This lift truck is not normally towed. If the traction system will not operate, make repairs at the location if possible. If the lift truck must be towed, refer to the Maintenance Manual.



### WARNING

Never carry a disabled lift truck unless the lift truck **MUST** be moved. The lift truck used to lift the disabled lift truck **MUST** have a rated capacity equal to or greater than the weight of the disabled lift truck. The capacity must be for a load center equal to half the width of the disabled lift truck. See the capacity plate on the disabled lift truck for the approximate total weight. The forks must extend the full width of the disabled lift truck. Put the weight of the disabled lift truck at the center of the forks and be careful not to damage the under side of the disabled lift truck. Tilt the mast back and travel slowly.



### WARNING

Make sure no one except the driver is near the lift trucks during towing. Both the tow truck and the disabled truck can cause personal injury during towing.



### WARNING

To avoid personal injury, use extra care when moving a lift truck during the following conditions:

- Brake does not operate correctly
- Steering does not operate correctly
- Tire is damaged
- Traction conditions are bad



### WARNING

Until repairs are complete, keep a **DO NOT OPERATE** tag on the control handle. Remove the key.



### CAUTION

Never carry the lift truck faster than the speed of a person walking. Steering can be difficult and motor damage can occur at higher speeds. Always travel smoothly without sudden starts.

The electric brake must be released before the lift truck can be moved. If there is not sufficient battery power, placing the control handle in the operating position will not release the electric brake. Refer to Towing The Lift Truck of the Maintenance Manual. Use the control handle to steer the lift truck while it is being towed. Use one hand and walk to one side

of the lift truck. Do not walk or stand between the towing vehicle and the lift truck.

### How to Tow the Lift Truck

#### WARNING

**Stay clear of the tow chain, towing vehicle, and the lift truck during the towing operation to prevent personal injury.**

#### WARNING

**Make sure no one except the driver is near the lift trucks during towing. Both the tow truck and the disabled truck can cause personal injury during towing.**

#### CAUTION

**Travel slowly and do not tow on grades. NEVER tow the lift truck faster than a normal walking speed. Always tow smoothly without sudden starts or stops.**

#### CAUTION

**Until repairs are complete, keep a DO NOT OPERATE tag on the control handle. Remove the key.**

1. Disconnect the battery, remove the hood, and fasten the chain to the lift truck. Make sure the tow chain has the capacity to tow the weight. Carefully fasten the tow chain completely around the motor and battery compartments on top of the forks. The chain must not cause damage to either lift truck.
2. The electric brake must be released before the lift truck can be towed. Disconnect connector 6 and plug in brake override connector. See Schematics.

**NOTE:** The brake override connector must be removed after repairs are completed before returning the truck to service. Otherwise the truck will not operate.

3. If there is not sufficient battery power, placing the control handle in the operating position will not release the electric brake.
4. Steer the lift truck with the control handle while it is being towed. Use one hand and walk to one side of the lift truck. Do not walk or stand between the towing vehicle and the lift truck.

5. Tow the lift truck slowly.
6. If another lift truck that has the drive wheels near the forks is used to tow the disabled lift truck, that lift truck must have weight added to the forks. The total weight of the lift truck and load must be equal to or greater than the weight of the disabled lift truck. Install a load of approximately half the maximum capacity on the forks of the lift truck that is used for towing. This load will increase the traction of the lift truck. Keep the load on the forks lowered as much as possible.

If the lift truck used for towing has a master drive unit (MDU) or drive unit similar to this lift truck, do **NOT** add weight to the forks. Additional weight on the forks may decrease the traction of the drive wheel(s). Make sure that the lift truck has a total weight equal to or greater than the weight of the disabled lift truck.

### HOW TO PUT A LIFT TRUCK ON BLOCKS

#### WARNING

**Do NOT put the lift truck on blocks if the surface is not solid, even, and level. Make sure that any blocks used to support the lift truck are solid, one-piece units. Put a block in front and back of the tires touching the ground to prevent movement of the lift truck.**

**Do not raise the lift truck by attaching an overhead crane to areas that will be damaged. Some of these points are not designed to support the weight of the lift truck. The lift truck can be damaged or it can fall causing serious personal injury. Attach the chain or sling to a support structure of the lift truck frame.**

See Figure 1.

### How to Raise Drive/Steer Tire

1. Put blocks on each side (front and back) of the load wheels to prevent movement of the lift truck.
2. Use a special low clearance hydraulic jack, crane, or another lift truck to raise the drive tire. Make sure that the jack, crane, or other lift truck has the correct capacity rating. The capacity must equal to  $2/3$  the weight of the lift truck including the battery. See the capacity plate.



3. Raise the lift truck only enough to suspend the drive tire. Install additional blocks under the frame near the drive tire.

### How to Raise Load Wheels

#### WARNING

Never raise the forks any higher than necessary to change the load wheels. Always raise both forks at the same time. Raising the forks too high can make the lift truck tip over and cause property damage or possible, personal injury.

1. Put blocks on both sides (front and back) of the drive tire to prevent movement of the lift truck.
2. Use an overhead crane and web sling under the forks to raise the load wheels. Another lift truck can also be used to raise the forks. Make sure that the crane and sling or other lift truck has a capacity of at least 2/3 the total weight of the lift truck as shown on the capacity plate.
3. Raise the forks only enough to suspend the wheels. Install blocks under the forks at the rear of the wheels to support the lift truck.

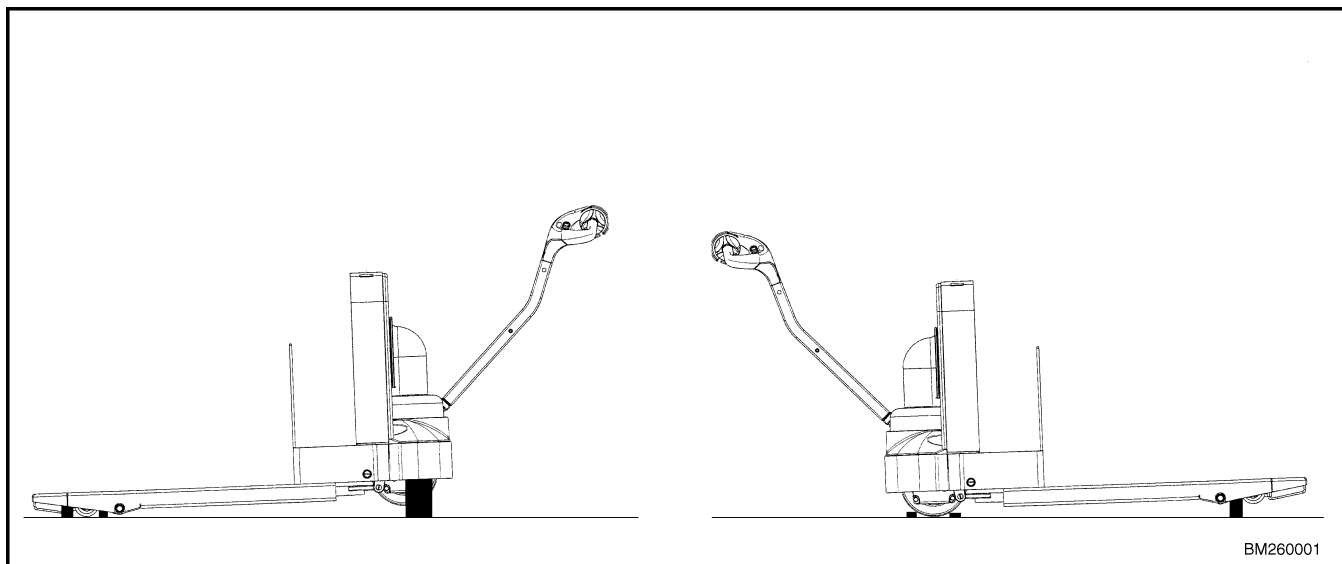

*Figure 1. Putting Lift Truck on Blocks*

### WELDING REPAIRS

#### WARNING

Forklift truck frames and components may have polyurethane paint. Welding, burning, or other heat sufficient to cause thermal decomposition of the paint may release isocyanates. These chemicals are allergic sensitizers to skin and respiratory tract and overexposure may occur without odor warning. Should work be performed, utilize good industrial hygiene practices including removal of all paint (prime and finish coats) to the metal around the area to be welded, local ventilation, and/or supplied-air respiratory protection.

#### WARNING

Remove the battery before welding. Welding can cause a fire and or an explosion. Make sure there is no fuel, oil, or grease near the weld area. Make sure the area is well ventilated.

#### CAUTION

When using an arc welder, always disconnect the battery connector to prevent damage to circuit components. Connect the welding ground clamp as close to the weld area as possible to prevent welding current from damaging bearings.

Observe previous WARNINGS and CAUTIONS before doing any welding.

## Battery Maintenance

### HOW TO CHARGE THE BATTERY

 **WARNING**

The acid in the electrolyte can cause personal injury. If electrolyte is spilled, flush the area with water. Use a solution of sodium bicarbonate (soda) to make the acid neutral. Acid in the eyes must be flushed with water immediately.

 **WARNING**

Batteries generate explosive hydrogen when they are being charged. Keep fire, sparks, and burning material away from the battery charger area. Prevent sparks from the battery connectors. Open the battery cover to disperse explosive gas.

 **WARNING**

Charge batteries only in the special area for charging batteries. When charging the batteries, keep the vent caps clean. The battery charger area must have ventilation so that explosive fumes are removed. Move the key to the OFF position and disconnect the battery when doing cleaning and maintenance.

 **WARNING**

If the lift truck has been operated using a battery that is almost discharged, inspect for welded contacts BEFORE connecting a charged battery. A contactor with welded contacts can cause operations that are not expected and possible personal injury when a charged battery is connected. Check the battery connector for damage.

 **CAUTION**

Never connect the battery charger plug to the plug of the lift truck. You can damage the traction control circuit. Always make sure the charger voltage is the correct voltage for the battery.

Correct use of the hydrometer and proper operation of the battery charger is important. Operate the battery charger according to the instructions of the charger manufacturer. Never let the battery discharge below the minimum value given by the battery manufacturer. A fully charged battery will

have a specific gravity of 1.265 to 1.310 at 25°C (77°F). See Table 1. Never charge a battery at a rate that will raise the electrolyte temperature above 49°C (120°F). Never permit a battery to stay discharged for long periods.

*Table 1. Specific Gravity Corrections*

Specific Gravity Reading	Electrolyte Temperature	Cor-rection Points	Cor-rect Value
1.210	31°C (87°F)	+0.003	1.213
1.210	27°C (80°F)	+0.001	1.211
1.210	25°C (77°F)	+0.000	1.210
1.210	18°C (64°F)	-0.004	1.206
+0.001 for each 1.7°C (3°F) from the 25°C (77°F). Base Value Degrees C + 17.8 × 1.8 = Degrees F.			

### Equalizing Charge

This charge is at a low rate and balances the charge in all of the cells. The equalizing charge is normally given approximately once a month. It is a charge at a slow rate for three to six hours in addition to the regular charging cycle. Do **NOT** give an equalizing charge more than once a week. The most accurate specific gravity measurement for a charged battery will be after an equalizing charge. If the difference in specific gravity is more than 0.020 between cells of a battery after an equalizing charge, there can be a cell that has a malfunction. Consult your battery dealer.

**NOTE:** Many customers have battery chargers that can follow a program to automatically charge a battery according to recommendations of the battery manufacturer. Use the recommendations of the battery manufacturer for charging the battery. Use only battery chargers approved by the battery manufacturer or dealer.

### Normal Charge

This charge is normally given to a battery that is discharged from normal operation. Many customers charge the battery at regular intervals that depend on use. This procedure will keep the battery correctly charged if the battery is not discharged below the limit. Always use a hydrometer to check the battery

if the battery is charged at regular intervals. Frequent charging of a battery that has a 2/3 or more charge can decrease the life of the battery.

### Maintenance Free Battery Charger

#### WARNING

To reduce the risk of fire, use only on circuits provided with 5 amps branch circuit protection in accordance with the National Electrical Code, ANSI/NFPA 70.

For lift trucks equipped with maintenance free batteries or industrial batteries, the battery connector must be disconnected from the truck and connected to a suitable battery charger. Refer to OPERATOR MANUAL.

### Battery Charger (W40Z only)

For lift trucks equipped with the standard battery pack and on-board charger, it is not required to disconnect the battery connector before charging the battery. Connect AC cord to a 120 volt AC outlet. This will automatically charge the batteries. Refer to OPERATOR MANUAL.

**NOTE:** The utility tray must remain open during charging to allow batteries proper ventilation.

### HOW TO CHANGE THE BATTERY

#### WARNING

Batteries are heavy and can cause personal injury or property damage. Do NOT put hands, arms, feet, or legs between the battery and a solid object. Make sure the capacity of the crane and spreader bar is greater than the weight of the battery. The weight of the battery is normally shown on the battery case. The maximum battery weight is shown on the lift truck capacity plate. The spreader bar must NOT be made of metal or it must have insulated straps.

#### WARNING

Put blocks under both sides of the frame in the area of the battery compartment. The blocks must prevent the lift truck from falling and causing personal injury or property damage.

#### CAUTION

If the lift truck was operated using a low battery, inspect for welded contacts BEFORE connecting a charged battery. The circuit will not reset and lift truck operation cannot be controlled if the contacts are welded. Prevent side-to-side movement of the battery by adjusting the brackets on each side of the battery and tighten the capscrews, lockwashers, and nuts to retain the batteries.

#### CAUTION

The replacement battery must fit the battery compartment. Make sure the battery cables have clearance to move during lifting and lowering of the forks. Make sure that the replacement battery is the correct voltage and weight as shown on the capacity plate. See Figure 2.

1. Move the key to the OFF position. Disconnect the battery. Use a spreader bar and lifting device to remove the battery.

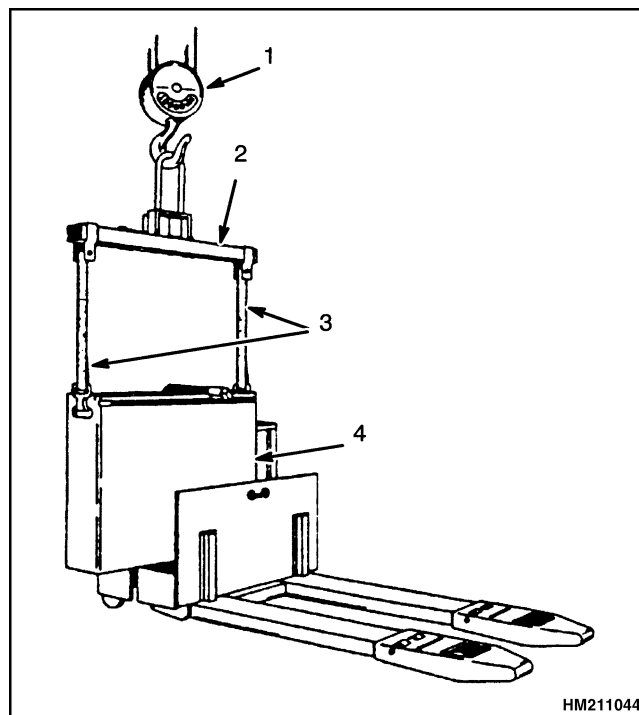

1. CRANE
2. SPREADER BAR
3. INSULATOR STRAPS
4. BATTERY

Figure 2. Changing the Battery

2. Position blocks under both sides of the truck in the area of the battery compartment.
3. Loosen and remove buckle and strap from around battery.
4. Lift the battery out of the truck. Do not let the battery move from side to side. Make sure the battery cables have clearance.
5. Before installing a new battery, make sure the battery is the correct size and weight for the lift truck. Make sure the battery has clearance for installation. Check that the battery connector can be attached to the lift truck connector without pulling during lifting and lowering operations. Do not damage the battery cables during installation. Install the battery.
6. Replace buckle and strap and tighten to prevent the battery from moving.
7. Remove the blocks from under the truck.
8. Connect the battery. Test the operation of the motorized hand truck before returning the truck to service.

## Maintenance Schedule

### CHECKS AND INSPECTION PROCEDURES



#### WARNING

Hyster Industrial Trucks are equipped with certain safety devices as standard equipment, for example: horns, reversing button, etc. If for any reason these safety devices are removed when the truck is being serviced, adjusted, repaired, or overhauled, these safety devices must be properly reinstalled before any testing or operation of the truck is to be done. Failure to comply with this warning could result in serious personal injury to the mechanic and/or the operator.



#### WARNING

Disconnect the battery before removing the hood.



#### WARNING

Do not operate a lift truck that needs repairs. Report the need for repairs immediately. If repair is necessary, put a DO NOT OPERATE tag on the control handle. Remove the key from the key switch.



#### CAUTION

**Disposal of lubricants and fluids must meet local environmental regulations.**

The Recommended Schedule of Maintenance is located in this section. The Maintenance Schedule has the time intervals for inspection, lubrication, and maintenance. The Maintenance Schedule is based on normal operations. Severe or unusual operating conditions will require a reduction in the recommended time periods in the Maintenance Schedule.

Your HYSTER dealer has the facilities and trained personnel to do complete lift truck maintenance. A complete program of inspection, lubrication, and maintenance will help your lift truck perform efficiently and operate over a longer period of time. Service manuals are available from your HYSTER dealer to help users who do their own maintenance.

Put the lift truck on a level surface. Lower the forks, disconnect the battery, and remove the hood. Check for any leaks and conditions that are not normal. Clean any oil spills.

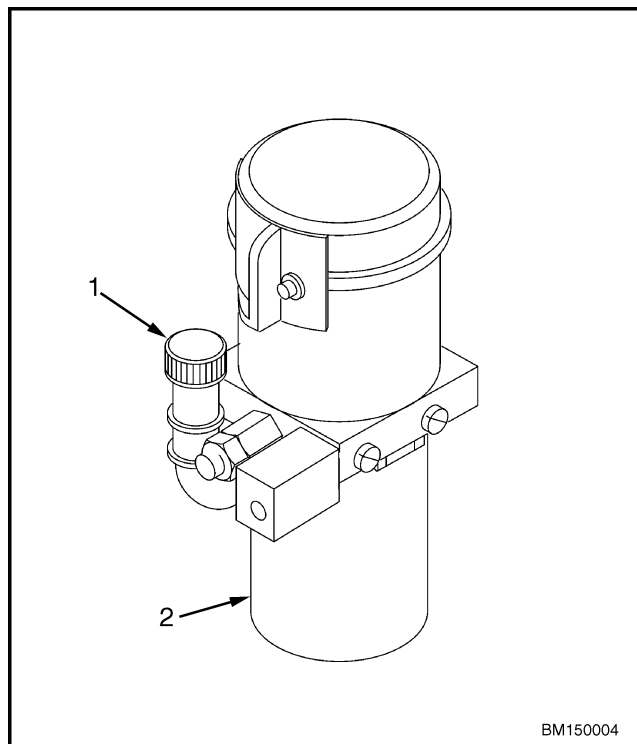

1. BREATHER CAP
2. HYDRAULIC OIL TANK

*Figure 3. Hydraulic Tank 12 Volt*

### Hydraulic System

**WARNING**

Do not try to locate hydraulic leaks by putting hands on pressurized hydraulic lines. Hydraulic oil can be injected into the body by pressure. Clean oil spills from the floor.

**WARNING**

The operating temperature of the hydraulic oil is 32 to 72°C (90 to 162°F).

**CAUTION**

Never operate the pump without oil in the hydraulic system. Operation of the hydraulic pump without oil will damage it.

**CAUTION**

Do not permit dirt to enter the hydraulic system when oil is added.

Make sure the temperature of the oil is at least 32°C (90°F). Make sure the forks are fully lowered. The fluid level full mark is labeled on the hydraulic tank. The hydraulic tank fluid level can be seen through the tank. Do not overfill. Oil will leak from the breather if too full. After filling, make sure to tighten the breather cap to prevent oil leaks. Check the hydraulic system for leaks and damaged or loose components. See Figure 3 and Figure 4.

**NOTE:** There is no filter on this hydraulic system. There is a screen on the pump inlet. This screen and the magnet in the bottom of the tank, must be cleaned each time the tank is removed for repairs.

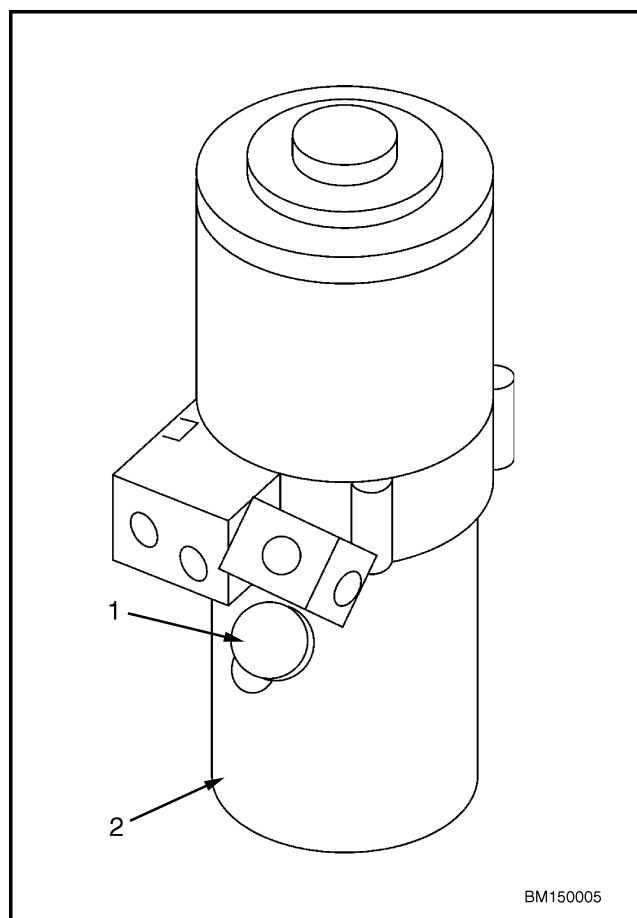

1. BREATHER CAP
2. HYDRAULIC OIL TANK

*Figure 4. Hydraulic Tank 24 Volt*

## Lifting Mechanism



### WARNING

Pressurized hydraulic oil can be injected into the body by pressure. Do not try to locate hydraulic leaks by putting hands on pressurized hydraulic components. Check for the location of high-pressure leaks by holding a piece of cardboard in front of the suspected area.



### WARNING

To avoid personal injury, never allow any part of your body under the forks. Do not put any part of your body in or through the lift mechanism.

1. Raise the forks slowly without a load. Check for smooth operation and mechanical interference. Mechanical interference is caused by damaged or worn linkage or shafts or by incorrect adjustment of the tension rods.
2. Check for damaged or worn linkage bushings or shafts.
3. Check for missing or loose shaft pins.
4. Check load wheels and support bearings, shafts, and shaft pins for wear, damage, or missing parts.
2. Check the operation of the brake switch. Release the control handle to allow it to return to the vertical position. Move the speed/direction control without lowering the control handle. The traction system must not operate.
3. Check the operation of the speed/direction control. Lower the control handle to release the brake. Slowly rotate the speed/direction control. The lift truck must accelerate smoothly. Rotate the control in the opposite direction. The lift truck must stop smoothly and then change direction. The control must return to the OFF position when released.
4. Check the operation of the lift and lower functions. Push the lift button and then the lower button. Check that the forks raise and lower.
5. Check the operation of the traction reverse function. Slowly rotate the speed/direction control for slow travel in the control handle direction. Push the traction reverse button without changing the position of the speed/direction control. The lift truck must stop and then accelerate in the opposite direction. The horn will sound. Once the lift truck changes direction and moves with the control handle trailing, release the traction reverse button without releasing the speed/direction control. The lift truck should not accelerate in the control handle direction. (Once the traction reverse button has been pressed, the traction motor should not accelerate the lift truck toward the control handle). Full direction control may be re-established by rotating the speed/direction control to the OFF position or moving the control handle to a brake ON position.

## Controls



### WARNING

If any function does not operate or operates incorrectly, report the faulty operation immediately. Do not operate the lift truck until the problem is corrected. Put a tag on the control handle stating DO NOT OPERATE. Remove the key and disconnect the battery.



### WARNING

Do the following checks in an area that is clear of other personnel or equipment.

1. Check the operation of the key switch. Functions should not operate with the key in the OFF position except the steering. Turn the key to the ON position. Lower control handle to the operating position. The horn, hydraulic system, traction system, and brake should now be operational.
6. Check the steering function. Move the control handle to the right and left. Check for smooth movement of the steer (drive) wheel in the same direction. Steering will be more difficult if the lift truck is stopped.
7. Check the operation of the optional creep speed button. The optional slow speed or "turtle" mode button enables the truck to be operated at a slow speed with the control handle in the fully upright position. To operate, press and hold the slow speed button, and rotate the speed/direction control button in the direction of desired travel. Releasing the button will re-apply the brake. If the control handle is lowered to the normal drive position while the slow speed button is depressed, the truck will continue to operate in the slow



speed mode until the button is released. The truck should operate at only 1.6 km/h (1 mph).

### Electrical and Battery



#### WARNING

Do not put tools on the battery.



#### WARNING

The acid in the electrolyte can cause injury. If the electrolyte is spilled, use water to flush the area and make the acid neutral with a solution of soda and water (one pound of baking or commercial soda to one gallon of water). Acid in the eyes must be flushed with water. Have a doctor check the eyes.



#### WARNING

Batteries generate explosive fumes. Keep the vents in the caps clean. Keep sparks or open flame away from the battery area. Do not make sparks with the battery connectors. Disconnect the battery when doing maintenance.

Check for loose or broken electrical connections and damaged wires or cables. Examine the battery case for damage and leakage. See the battery dealer in the area to repair any damage to the battery or cables.



#### WARNING

Broken electrical connections, damaged wires or cables, and leakage or corrosion from the battery can cause the electrical controls of the lift truck to operate incorrectly.

Keep the battery case, top cover, and battery areas clean and painted. Use a water and soda solution to clean the battery and the battery area (one pound of baking or commercial soda ash to one gallon of water). Keep the top of the battery clean, dry and free of corrosion.

## Recommended Schedule of Maintenance

Although this Recommended Schedule of Maintenance is intended for use with all motorized hand lift truck models, not all models are equipped with all the items listed in this schedule. Be certain this schedule is read thoroughly and all operations are

**NOTE:** The following electrolyte level and specific gravity checks are not necessary for low maintenance batteries.

Check that the vent caps are clear. Check the electrolyte level daily on a minimum of one cell and on all cells every week. Fill to the correct level according to the battery manufacturer's recommendations. Add only distilled water. Use a hydrometer to check that the battery is not discharged below the minimum specific gravity given by the manufacturer and has enough charge to complete a work period.

### Wheels and Tires

Check the drive tire, caster, and load wheels for foreign material, cuts, and tears. Remove all foreign material and smooth any cuts or tears to prevent further damage. See Figure 5.

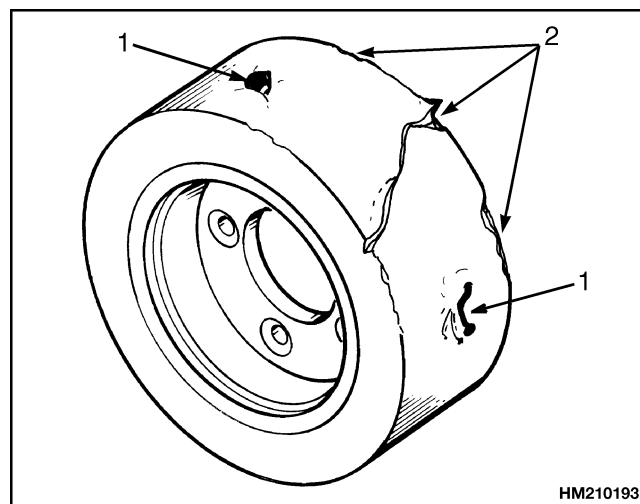

1. SMOOTH EDGES
2. REMOVE NAILS, GLASS, AND ALL METAL

*Figure 5. Tires*

**NOTE:** The load wheel bearings have lube fittings. Under normal conditions it is recommended that they be lubricated every 50 hours minimum or once per month. The load wheel bearings are cleaned and repacked every 1000 hours or once per year.

followed. If in doubt of any procedure or component to be inspected, adjusted and lubricated, or if the truck is specially equipped and used for special applications, consult your nearest authorized Hyster Industrial Truck Dealer for assistance.

**NOTE:** Some items on the following charts may not be applicable to your truck.

<b>Legend</b>			
<b>A - Every 8 Hours</b> <b>B - Every 350 Hours</b> <b>C - Every 2000 Hours</b>	<b>X - Indicates Visual Inspection, Repair, or Replace as Required</b> <b>O - Indicates Drain and Fill</b>		
<b>SAFETY AND OPERATIONAL CHECK</b> (Prior to each shift) Only the 8 hour CHECKS are to be performed by the operator. Have a <b>qualified</b> mechanic correct all problems in accordance with appropriate <b>HYSTER</b> maintenance instructions.			
	<b>A</b>	<b>B</b>	<b>C</b>
Leaks - Hydraulic Fluid	<b>X</b>		
Tires - Condition (See Note 1)	<b>X</b>		
Forks - Condition	<b>X</b>		
Load Backrest - Cracks and Mounting	<b>X</b>		
Hydraulic Hoses - Check Visually	<b>X</b>		
Safety Warnings - Attached (Refer to Parts Manual for Location)	<b>X</b>		
<b>Internal Checks:</b>			
Battery - Water/Electrolyte Level and Charge	<b>X</b>		
Hydraulic Tank Fluid Level - Check Level	<b>X</b>		
Operating Manual in Container	<b>X</b>		
Nameplate Attached - Information Matches Model, Serial Number & Attachments	<b>X</b>		
Battery Restraints in Place	<b>X</b>		
<b>Controls (Turn Truck On) Unusual Noises Must Be Investigated Immediately:</b>			
Brake System - Functioning Smoothly	<b>X</b>		
Directional/Speed Control- Functioning Smoothly	<b>X</b>		
Lift and Lower Control - Functioning Smoothly	<b>X</b>		
Gauges, Horn, and Fuses - Functioning	<b>X</b>		
Steering Operation - Functioning Smoothly	<b>X</b>		
<b>NOTES:</b> 1. Tires - Condition affects stability, safety, and load capacity that can be handled safely. 2. Under normal conditions it is recommended that the Load Wheel Bearings be lubricated every 200 hours minimum. The load wheel bearings are cleaned and repacked every 2000 hours. 3. The presence of hydraulic fluid on cylinder rods and fittings does not necessarily indicate a leak. 4.  Recycle all waste oils.			





**NOTE:** The following inspections and necessary corrections are the responsibility of the user.

<b>Legend</b>			
<b>A - Every 8 Hours</b> <b>B - Every 350 Hours</b> <b>C - Every 2000 Hours</b>	<b>X - Indicates Visual Inspection, Repair, or Replace as Required</b> <b>O - Indicates Drain and Fill</b>		
<b>LUBRICATION CHECK</b>	<b>A</b>	<b>B</b>	<b>C</b>
Blow off, clean when necessary and inspect for damage.			
Lubricate - Chassis (All Fittings)		<b>X</b>	
All Linkage and Load Wheels (See Note 2)		<b>X</b>	
Clean and Repack Load Wheel Bearings			<b>X</b>
Hydraulic Tank Oil Level		<b>X</b>	<b>O</b>
Hydraulic Tank Breather		<b>X</b>	
Caster Wheel Clearance		<b>X</b>	
Drive Unit Oil Level		<b>X</b>	<b>O</b>
<b>NOTES:</b>			
1. Tires - Condition affects stability, safety, and load capacity that can be handled safely.			
2. Under normal conditions it is recommended that the Load Wheel Bearings be lubricated every 200 hours minimum. The load wheel bearings are cleaned and repacked every 2000 hours.			
3. The presence of hydraulic fluid on cylinder rods and fittings does not necessarily indicate a leak.			
4.  Recycle all waste oils.			

<b>Legend</b>			
<b>A - Every 8 Hours</b> <b>B - Every 350 Hours</b> <b>C - Every 2000 Hours</b>	<b>X - Indicates Visual Inspection, Repair, or Replace as Required</b> <b>O - Indicates Drain and Fill</b>		
<b>HYDRAULIC SYSTEM CHECK</b>	<b>A</b>	<b>B</b>	<b>C</b>
Hydraulic Pump for Noise and Operation		<b>X</b>	
Hydraulic Control Valve for Leaks and Operation		<b>X</b>	
Relief Valve Settings		<b>X</b>	
<b>NOTES:</b>			
1. Tires - Condition affects stability, safety, and load capacity that can be handled safely.			
2. Under normal conditions it is recommended that the Load Wheel Bearings be lubricated every 200 hours minimum. The load wheel bearings are cleaned and repacked every 2000 hours.			
3. The presence of hydraulic fluid on cylinder rods and fittings does not necessarily indicate a leak.			
4.  Recycle all waste oils.			

Legend			
<b>A - Every 8 Hours</b> <b>B - Every 350 Hours</b> <b>C - Every 2000 Hours</b>	<b>X - Indicates Visual Inspection, Repair, or Replace as Required</b> <b>O - Indicates Drain and Fill</b>		
All Hoses, Tubing and Fittings for Wear and Leaks		X	
For General Leaks		X	
<b>NOTES:</b>			
1. Tires - Condition affects stability, safety, and load capacity that can be handled safely.			
2. Under normal conditions it is recommended that the Load Wheel Bearings be lubricated every 200 hours minimum. The load wheel bearings are cleaned and repacked every 2000 hours.			
3. The presence of hydraulic fluid on cylinder rods and fittings does not necessarily indicate a leak.			
4.  Recycle all waste oils.			

Legend			
<b>A - Every 8 Hours</b> <b>B - Every 350 Hours</b> <b>C - Every 2000 Hours</b>	<b>X - Indicates Visual Inspection, Repair, or Replace as Required</b> <b>O - Indicates Drain and Fill</b>		
<b>DRIVE UNIT CHECK</b>	<b>A</b>	<b>B</b>	<b>C</b>
Brake Wear and Adjustment		X	
Electric Motor and Drive Unit Mounting Bolts		X	
Wheel Bolts - Torque to Specifications		X	
<b>NOTES:</b>			
1. Tires - Condition affects stability, safety, and load capacity that can be handled safely.			
2. Under normal conditions it is recommended that the Load Wheel Bearings be lubricated every 200 hours minimum. The load wheel bearings are cleaned and repacked every 2000 hours.			
3. The presence of hydraulic fluid on cylinder rods and fittings does not necessarily indicate a leak.			
4.  Recycle all waste oils.			

<b>Legend</b>				
<b>A - Every 8 Hours</b> <b>B - Every 350 Hours</b> <b>C - Every 2000 Hours</b>	<b>X - Indicates Visual Inspection, Repair, or Replace as Required</b> <b>O - Indicates Drain and Fill</b>			
<b>ELECTRICAL SYSTEM CHECK</b>		<b>A</b>	<b>B</b>	<b>C</b>
<b>NOTE: DO NOT use Steam to Clean Electrical Parts</b>				
Clean all Controls			<b>X</b>	
Interlock Switches - Functioning			<b>X</b>	
All Motors - Clean with Compressed Air - Functioning			<b>X</b>	
All Motors - Clean Power Wire Terminals - Functioning			<b>X</b>	
Battery Box and Connectors - Neutralize and Clean			<b>X</b>	
Battery Condition - Physical and Electrical		<b>X</b>	<b>X</b>	
All Wire Connections - Tightness and Corrosion			<b>X</b>	
Contactors - Tips and Wire Connections - Tightness and Corrosion				<b>X</b>
<b>NOTES:</b> 1. Tires - Condition affects stability, safety, and load capacity that can be handled safely. 2. Under normal conditions it is recommended that the Load Wheel Bearings be lubricated every 200 hours minimum. The load wheel bearings are cleaned and repacked every 2000 hours. 3. The presence of hydraulic fluid on cylinder rods and fittings does not necessarily indicate a leak. 4.  Recycle all waste oils.				

<b>Legend</b>			
<b>A - Every 8 Hours</b> <b>B - Every 350 Hours</b> <b>C - Every 2000 Hours</b>	<b>X - Indicates Visual Inspection, Repair, or Replace as Required</b> <b>O - Indicates Drain and Fill</b>		
<b>GENERAL CHECK</b>	<b>A</b>	<b>B</b>	<b>C</b>
All Bolts, Nuts, Cotter Pins, Etc.			<b>X</b>
<b>NOTES:</b> 1. Tires - Condition affects stability, safety, and load capacity that can be handled safely. 2. Under normal conditions it is recommended that the Load Wheel Bearings be lubricated every 200 hours minimum. The load wheel bearings are cleaned and repacked every 2000 hours. 3. The presence of hydraulic fluid on cylinder rods and fittings does not necessarily indicate a leak. 4.  Recycle all waste oils.			

<b>Legend</b>			
<b>A - Every 8 Hours</b> <b>B - Every 350 Hours</b> <b>C - Every 2000 Hours</b>	<b>X - Indicates Visual Inspection, Repair, or Replace as Required</b> <b>O - Indicates Drain and Fill</b>		
<b>ROAD AND LOAD TEST TRUCK</b> <b>The following items must be tested at initial installation of the truck and after every maintenance inspection or repair.</b> Test the rated load in a clear area. Report any questionable functions or unusual noises.			
Steering			
Brake System			
Emergency Disconnect			
<b>NOTES:</b> 1. Tires - Condition affects stability, safety, and load capacity that can be handled safely. 2. Under normal conditions it is recommended that the Load Wheel Bearings be lubricated every 200 hours minimum. The load wheel bearings are cleaned and repacked every 2000 hours. 3. The presence of hydraulic fluid on cylinder rods and fittings does not necessarily indicate a leak. 4.  Recycle all waste oils.			