

# **SERVICE REPAIR**

Hyster H177 (H2.00-H3.20XM Europe) Forklift

# **MANUAL**

# ***HYSTER***

# **GM ENGINES**

**4-153, 4-181, 3.0L, 6-250**

**S30E; S40/50E; S60/70/80/100/120E; S40/50F;  
S2.00/3.00XL (S40/50/60XL);  
H2.00/3.00XL (H40/50/60XL);  
S2.00/2.50/3.00/3.20XM  
(S40/45/50/55/60/65XM) [D187];  
H2.00/2.50/3.00/3.20XM (H40/45/50/55/60/65XM);  
H45-65XM [H177]; H30-60H; H40/50J; H60J; H60JS;  
H60/70/80/100/110E; H110/130/150F; P40-50A**

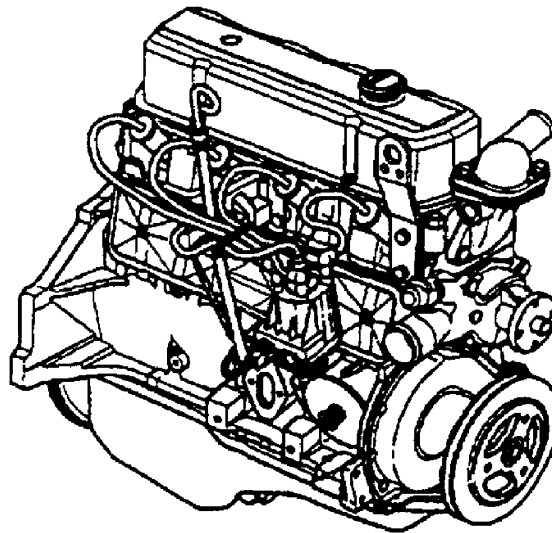

HM090000

# ***HYSTER***

# SAFETY PRECAUTIONS

## MAINTENANCE AND REPAIR

- When lifting parts or assemblies, make sure all slings, chains, or cables are correctly fastened, and that the load being lifted is balanced. Make sure the crane, cables, and chains have the capacity to support the weight of the load.
- Do not lift heavy parts by hand, use a lifting mechanism.
- Wear safety glasses.
- **DISCONNECT THE BATTERY CONNECTOR** before doing any maintenance or repair on electric lift trucks.
- Disconnect the battery ground cable on internal combustion lift trucks.
- Always use correct blocks to prevent the unit from rolling or falling. See **HOW TO PUT THE LIFT TRUCK ON BLOCKS** in the **Operating Manual** or the **Periodic Maintenance** section.
- Keep the unit clean and the working area clean and orderly.
- Use the correct tools for the job.
- Keep the tools clean and in good condition.
- Always use **HYSTER APPROVED** parts when making repairs. Replacement parts must meet or exceed the specifications of the original equipment manufacturer.
- Make sure all nuts, bolts, snap rings, and other fastening devices are removed before using force to remove parts.
- Always fasten a **DO NOT OPERATE** tag to the controls of the unit when making repairs, or if the unit needs repairs.
- Be sure to follow the **WARNING** and **CAUTION** notes in the instructions.
- Gasoline, Liquid Petroleum Gas (LPG), Compressed Natural Gas (CNG), and Diesel fuel are flammable. Be sure to follow the necessary safety precautions when handling these fuels and when working on these fuel systems.
- Batteries generate flammable gas when they are being charged. Keep fire and sparks away from the area. Make sure the area is well ventilated.

**NOTE:** The following symbols and words indicate safety information in this manual:



### **WARNING**

**Indicates a condition that can cause immediate death or injury!**



### **CAUTION**

**Indicates a condition that can cause property damage!**

## TABLE OF CONTENTS

|  |    |
|--|----|
| General .....  | 1  |
| Description .....  | 1  |
| Engine Removal and Installation .....  | 3  |
| Cylinder Head and Valve Mechanism Repair .....                                       | 3  |
| Cylinder Head, Remove .....  | 3  |
| Cylinder Head, Disassemble .....   | 3  |
| Clean and Inspect .....  | 3  |
| Valves and Valve Seats .....   | 6  |
| Studs for Rocker Arms .....  | 6  |
| Hydraulic Valve Lifters, Replace .....   | 7  |
| Hydraulic Valve Lifters, Clean and Inspect .....                                     | 7  |
| Cylinder Head, Assemble .....  | 7  |
| Cylinder Head, Install .....   | 7  |
| Valve Clearance, Adjust .....  | 8  |
| Rocker Arm Cover, Install .....  | 9  |
| Timing Gear Cover Repair .....   | 9  |
| Remove .....   | 9  |
| Install .....  | 10 |
| Camshaft Repair .....  | 11 |
| Remove .....   | 11 |
| Inspect .....  | 11 |
| Camshaft Bearing .....   | 12 |
| Remove .....   | 12 |
| Install .....  | 12 |
| Distributor Repair .....   | 13 |
| Remove .....   | 13 |
| Install .....  | 13 |
| Lubrication System Repair .....  | 14 |
| Oil Sump .....   | 14 |
| Remove .....   | 14 |
| Install .....  | 14 |
| Oil Pump .....   | 14 |
| Remove .....   | 14 |
| Disassemble and Repair .....   | 14 |
| Assemble .....   | 15 |
| Install .....  | 15 |
| Piston and Connecting Rod Assemblies Repair .....                                    | 15 |
| Connecting Rod Bearings, Replace .....   | 15 |
| Piston and Connecting Rod Assemblies, Remove .....                                   | 16 |
| Piston and Connecting Rod Assemblies, Disassemble .....                              | 17 |
| Piston, Clean and Inspect .....  | 17 |
| Cylinder Bores, Inspect and Repair .....   | 17 |
| Piston Rings, Inspect .....  | 18 |
| Piston and Connecting Rod Assemblies, Assemble .....                                 | 18 |
| Piston and Connecting Rod Assemblies, Install .....                                  | 20 |
| Crankshaft Repair .....  | 20 |
| Main Bearings, Replace .....   | 20 |
| Oil Seal for Rear Main Bearing, Replace (GM 4-181 and 3.0L Only) .....               | 21 |
| Oil Seal for Rear Main Bearing, Replace (Engines That Have Two-Piece Oil Seal) ..... | 21 |
| Remove .....   | 23 |
| Inspect and Repair .....   | 23 |

## TABLE OF CONTENTS (Continued)

|   |    |
|---|----|
| Main Bearing and Journal Clearance, Check ..... | 24 |
| Install .....                                   | 24 |
| Flywheel and Flywheel Housing Repair .....      | 25 |
| Remove .....                                    | 26 |
| Ring Gear, Replace .....                        | 27 |
| Install .....                                   | 27 |
| Cooling System Repair .....                     | 27 |
| Coolant Pump .....                              | 27 |
| Fan Drive .....                                 | 27 |
| Viscous Fan Drive .....                         | 27 |
| Engine Specifications .....                     | 29 |
| Engine Data .....                               | 29 |
| Cylinder Head .....                             | 30 |
| Hydraulic Valve Lifter .....                    | 30 |
| Camshaft .....                                  | 31 |
| Pistons .....                                   | 32 |
| Cylinder Bore .....                             | 32 |
| Crankshaft .....                                | 33 |
| Connecting Rods .....                           | 33 |
| Cooling System .....                            | 34 |
| Lubrication System .....                        | 34 |
| Torque Specifications .....                     | 34 |
| Troubleshooting .....                           | 35 |

This section is for the following models:

S30E; S40/50E; S60/70/80/100/120E; S40/50F; S2.00/3.00XL  
(S40/50/60XL); H2.00/3.00XL (H40/50/60XL); S2.00/2.50/3.00/3.20XM  
(S40/45/50/55/60/65XM) [D187];  
H2.00/2.50/3.00/3.20XM (H40/45/50/55/60/65XM); H45-65XM [H177];  
H30-60H; H40/50J; H60J; H60JS; H60/70/80/100/110E;  
H110/130/150F; P40-50A

## General



### WARNING

Some gaskets used in this engine can contain dangerous fibers. Breathing dust from these fibers is a cancer or lung disease hazard. Do not create dust! Use vacuum equipment for asbestos or follow the cleaning procedure described below.

- Make sure the gasket material is wet with water or oil to prevent particles in the air.
- Use a hand scraper to remove old gasket material. Do not use a power tool or compressed air.
- Discard all asbestos material in a closed container while it is still wet.

Put a DANGEROUS FIBERS warning label on the container. Discard dangerous fiber material safely.



### CAUTION

Disconnect the battery cables before doing any disassembly and repair to the engine or parts of the electrical system.

The diodes and resistors in the electrical system can be damaged if the following cautions are not followed:

- Do not disconnect the battery when the engine is running. The voltage surge can damage the diodes and resistors.
- Do not disconnect an electric wire before the engine is stopped and the switches are OFF.
- Do not cause a short circuit by connection of the electric wires to the wrong terminals. Make sure a correct identification is made of the wire before it is connected.
- Make sure a battery is the correct voltage and polarity before it is connected.
- Do not check for current flow by making a spark because the electronic components can be damaged.

This section has the description and the repair instructions for the engine. Disassembly, cleaning, assembly, specifications, and troubleshooting are included.

## Description

The GM engines described in this section are the four-cylinder and six-cylinder models that have the arrangement of the cylinders in a straight line. These engines have a similar design. The number one cylinder for these engines is toward the cooling fan. These engines can have either a gasoline or an LPG fuel system. See Figure 1.

The GM 4-153 engine is used in some models of 2.00 to 3.00 ton (4000 to 6000 lb) capacity lift trucks from June 1975 until June 1990. During 1990, production of the GM 4-153 engine was stopped and it was replaced with variations of the GM 4-181 engine. The GM 4-181 engine is also used in some models of 2.00 to 3.00 ton (4000 to 6000 lb) capacity lift trucks beginning in 1978. The two engines are the same design except for different displacements. The GM 4-181 engines installed in the lift trucks with serial code B187 [S2.00-3.00XL (S40-60XL)] beginning in 1990 have a different camshaft than the GM 4-181 engines used in the lift trucks with other serial codes.

The GM 4-181 engines installed in the lift trucks with serial codes C187 [S2.00-3.00XL (S40-60XL)]

and serial codes B177 and C177 [H2.00-3.00XL (H40-60XL)] are the same engine.

The GM 3.0L engine is a later model of the 4-181 engine. It is used in the S/H2.00-3.20XM (S/H40-65XM) lift trucks.

The GM 6-250 engine is used in some models of 3.00 to 7.50 ton (6000 to 15,000 lb) capacity lift trucks from 1975 until 1988.

A camshaft in the engine block operates the overhead valves with push rods. A cast iron crankshaft gear drives a camshaft gear. The cam lobes are hardened and have a taper with the high side toward the rear of the engine. The valve lifters have a rounded surface where they contact the cam lobes. This combination of surfaces causes the valve lifters to rotate during engine operation. All of the engines have hydraulic valve lifters.

Each rocker arm rotates on a pivot ball stud fastened to the cylinder head. The valve guides and valve seats are part of the cylinder head. The exhaust valve seats are induction hardened.

**Thanks very much for your reading,  
Want to get more information,  
Please click here, Then get the complete  
manual**

**JustClickHere** 

**NOTE:**

**If there is no response to click on the link above,  
please download the PDF document first, and then  
click on it.**

**Have any questions please write to me:  
[admin@servicemanualperfect.com](mailto:admin@servicemanualperfect.com)**

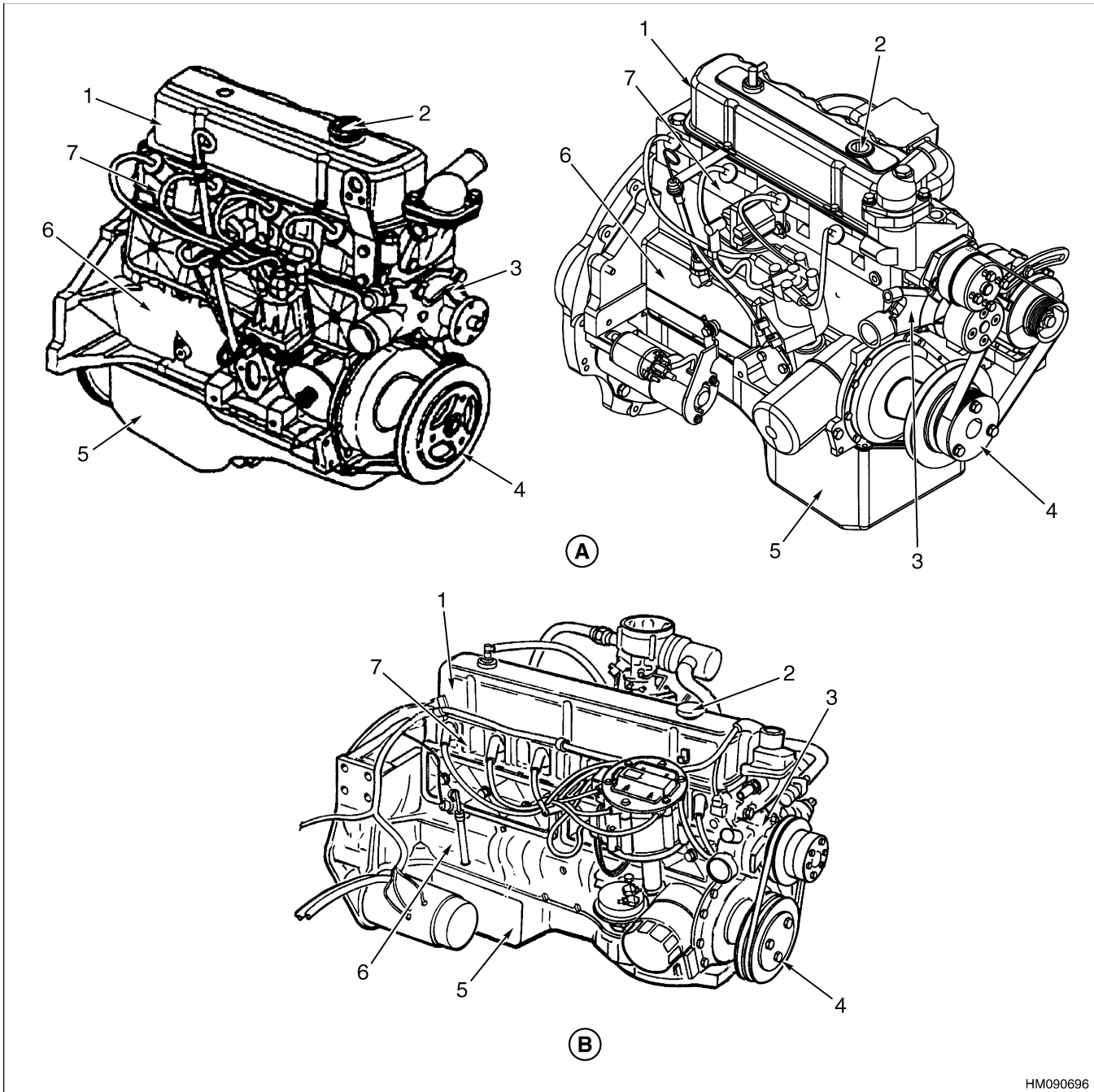

HM090696

**A. 4-153, 4-181, AND 3.0L ENGINES**

- 1. ROCKER ARM COVER
- 2. FILL CAP FOR ENGINE OIL
- 3. WATER PUMP
- 4. VIBRATION DAMPENER

**B. 6-250 ENGINE**

- 5. OIL SUMP
- 6. ENGINE BLOCK
- 7. CYLINDER HEAD ASSEMBLY

**Figure 1. GM Engines**



The crankshaft in the four-cylinder engines has five main bearings. The crankshaft in the six-cylinder engine has seven main bearings. The rear main bearing in all engines is the thrust bearing.

The pistons are aluminum alloy and have three piston rings. The two compression rings each have a

different design. Some oil control rings have three parts that must be assembled when the oil control ring is installed on the piston.

The specifications for engine repair are shown in Engine Specifications at the end of this section.

## Engine Removal and Installation

**NOTE:** The removal and installation procedures for the engine and transmission are not included in this

section. See the **Frame** section for the model of lift truck for these procedures.

## Cylinder Head and Valve Mechanism Repair

### CYLINDER HEAD, REMOVE

1. Disconnect the battery cables at the battery.
2. Drain the cooling system.
3. Disconnect and remove the coolant hose from the housing for the thermostat.
4. Remove or disconnect the air filter.
5. Disconnect the PCV valve.
6. Disconnect the wires and hoses fastened to brackets on the rocker arm cover.
7. Disconnect the spark plug wires.
8. Disconnect the linkages, fuel lines, and hoses for the fuel system.
9. Disconnect the exhaust pipe at the exhaust manifold and remove the intake and exhaust manifolds.
10. If necessary, remove the alternator and bracket.
11. Remove the dipstick tube for engine oil.
12. Remove the rocker arm cover.

**NOTE:** Keep the rocker arm assemblies and the push rods in order so that they will be installed in the same position.

13. Remove the rocker arms and the push rods.

14. Loosen the cylinder head bolts in two or three steps. Do not completely loosen the cylinder head bolts during the first sequence. Remove the cylinder head bolts. Remove the cylinder head and the gasket.

### CYLINDER HEAD, DISASSEMBLE

1. Use a compressor tool to compress the valve springs and remove the retainers. See Figure 2 and Figure 3. Release the compressor tool and remove the spring cap, (rotators when used), oil shield, and valve springs. Remove the oil seal and any shims from the springs.
2. Remove the valves from the cylinder head and put them in a rack so that the valves can be installed again in their same positions in the cylinder head.

### CLEAN AND INSPECT

1. Clean the carbon from the combustion chambers and the valve ports.
2. Clean the valve guides. Use a tool as shown in the example in Figure 4.
3. Clean the push rods and rocker arms.
4. Clean the surfaces of the cylinder head where the gaskets fit.
5. Inspect the cylinder head for cracks in the exhaust ports, combustion chambers, and external surfaces.

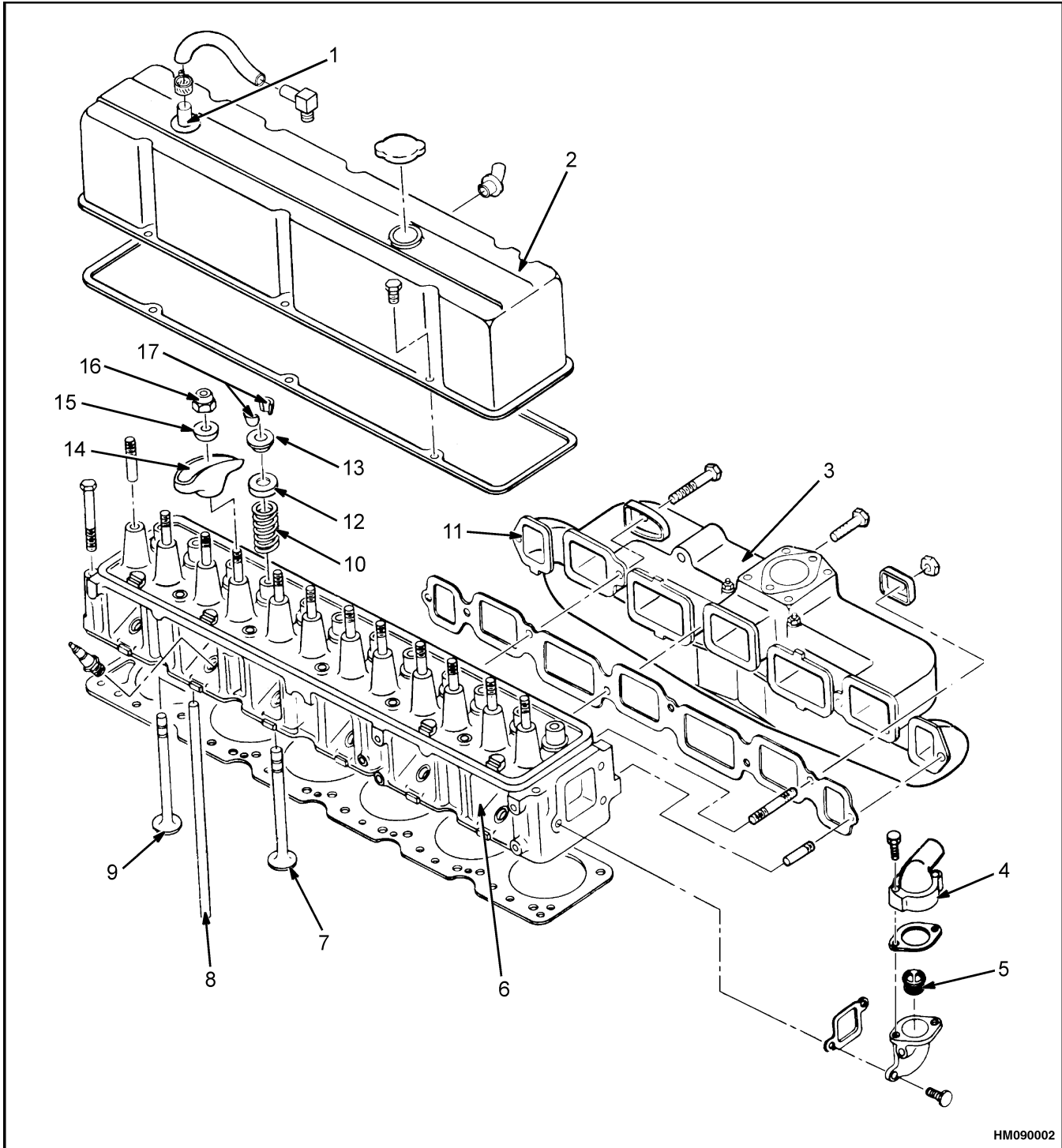

HM090002

Figure 2. Cylinder Head

*Legend for Figure 2*

**NOTE:** GM 6-250 SHOWN.

- |                     |                      |
|---------------------|----------------------|
| 1. PCV VALVE        | 10. VALVE SPRING     |
| 2. ROCKER ARM COVER | 11. EXHAUST MANIFOLD |
| 3. INTAKE MANIFOLD  | 12. SHIELD           |
| 4. OUTLET           | 13. SPRING CAP       |
| 5. THERMOSTAT       | 14. ROCKER ARM       |
| 6. CYLINDER HEAD    | 15. BALL             |
| 7. INTAKE VALVE     | 16. NUT              |
| 8. PUSH ROD         | 17. RETAINER         |
| 9. EXHAUST VALVE    |                      |

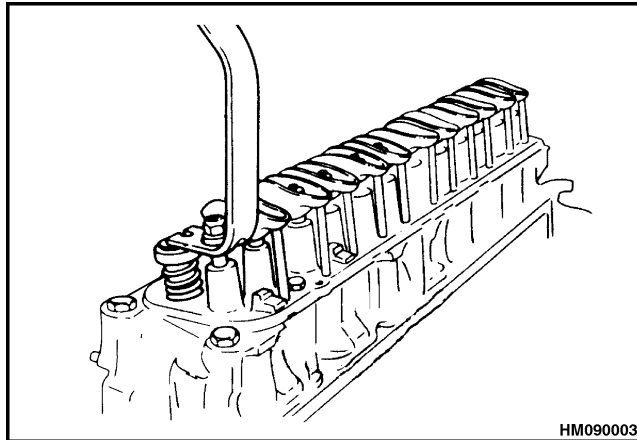

**Figure 3. Valve Spring Compression**

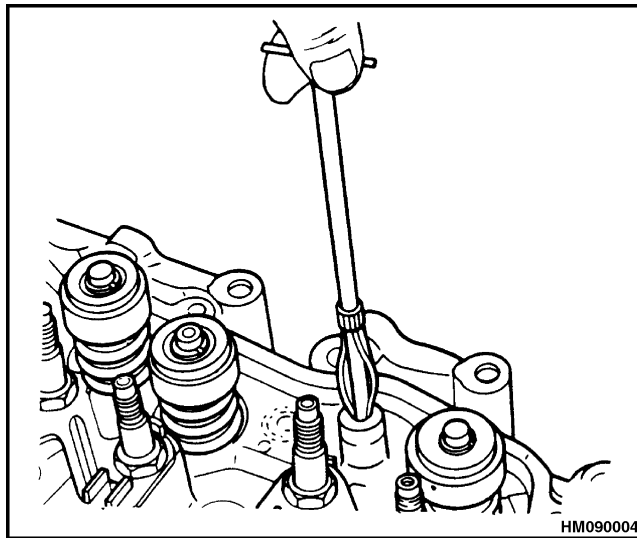

**Figure 4. Valve Guide Cleaning Tool**

6. Inspect the valves for burned or damaged areas in the seat surfaces. Inspect for cracks and damaged or worn valve stems.
7. Check the clearance of each valve stem in its valve guide. Use the following procedure:

- a. Use a micrometer to measure the diameter of the valve stem in three places: top, center, and bottom. The stems of exhaust valves have a small taper. The end of the valve stem near the spring is approximately 0.025 mm (0.001 in.) larger than the diameter near the valve head. Use a hole gauge to measure the bore in the valve guide.
- b. Another method of measuring the clearance of the valve stem in its valve guide is to use a dial indicator as shown in Figure 5. Put the dial indicator so that it can measure the side-to-side movement of the valve stem. Lower the valve away from its valve seat approximately 3 mm (0.1 in.). Move the valve stem from side to side and check the measurement on the dial indicator.

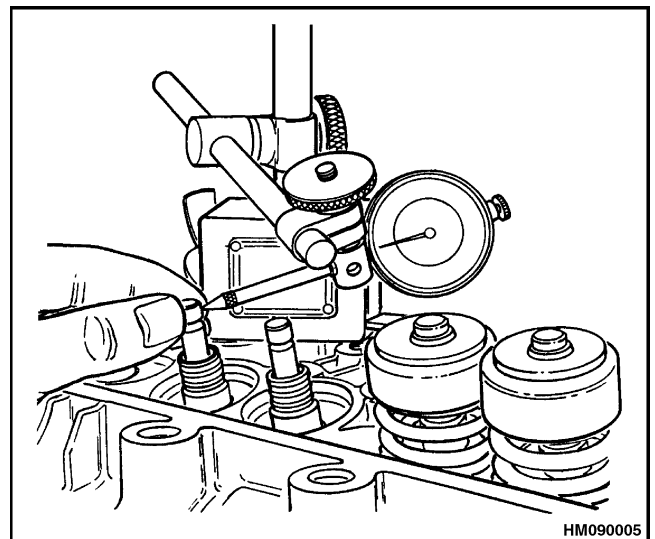

**Figure 5. Valve Guide and Valve Clearance Check**

- c. The maximum clearance between the valve stems and their valve guides is shown in the Engine Specifications.
  - d. If the clearance between the valve stem and its valve guide is greater than the specification, a valve with an oversize stem must be installed. Use a reamer to make the bore the correct diameter for the next oversize valve. See the **Parts Manual** for oversize valves.
8. Use a valve spring tester to check the valve springs. A typical tester is shown in Figure 48. The specifications for the valve springs are shown in the Engine Specifications.
  9. Inspect the rocker arm bolts for wear and damage.

## VALVES AND VALVE SEATS

The condition and alignment of the valves to their valve seats are important so that the engine will operate correctly. Before any work is done on the valve seats, make sure the clearance of the valve stems in their valve guides is within specifications.

A correction for minimum wear and damage to the valve and seat can be done by a process called lapping. When the valve seats are lapped, keep the valve seats within the specifications. Make sure all of the lapping compound is removed from the valve and valve seat when the process is completed.

**NOTE:** Some engines have valve seats that can be replaced. If the valve seats cannot be repaired or replaced, install a new cylinder head.

Damaged valve seats can be repaired with a cutter tool. If the valve seat cannot be repaired so that the valve depth is within specifications, the cylinder head must be replaced. The specifications for the valve seats are shown in Figure 6.

## STUDS FOR ROCKER ARMS

Replace a stud that has damaged threads or is loose in the cylinder head. See the **Parts Manual** for oversize studs.

1. Remove the old stud. Install a spacer, flat washer, and nut to the damaged stud. Use a

wrench to remove the damaged stud. See Figure 7.

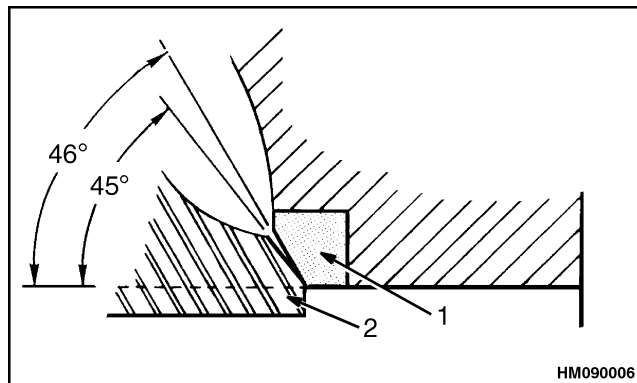

1. VALVE SEAT
2. MINIMUM THICKNESS OF VALVE HEAD IS 0.80 mm (0.031 in.)

**Figure 6. Intake and Exhaust Valve Seat Specifications**

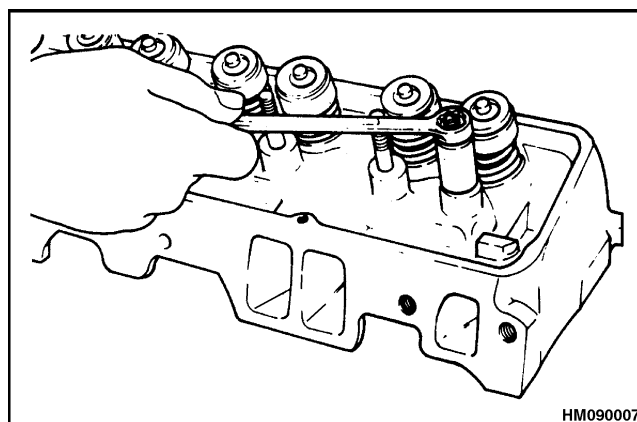

**Figure 7. Rocker Arm Stud Removal**



### CAUTION

**Do not try to install an oversize stud without reaming the stud hole to the new size. Installation of an oversize stud without reaming the stud hole can cause cracks in the cylinder head.**

2. Use a reamer of the correct size for the new oversize stud. Apply SAE 90 lubricant to the new stud during installation. Install the new stud as shown in Figure 8.

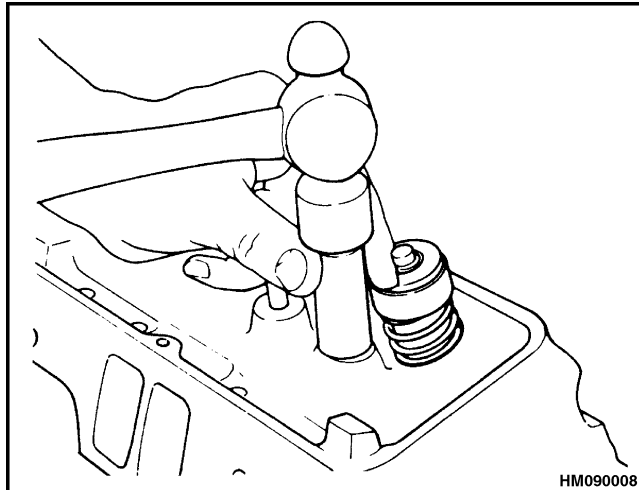

**Figure 8. Rocker Arm Stud Installation**

### HYDRAULIC VALVE LIFTERS, REPLACE

The hydraulic valve lifters normally do not need service unless they are dirty or damaged. The hydraulic valve lifters must be clean to operate correctly. If the lifters make noise or do not operate correctly, replace them. The lifters can be removed with a flexible magnet after the push rods are removed.

### HYDRAULIC VALVE LIFTERS, CLEAN AND INSPECT



#### WARNING

**Cleaning solvents can be flammable and toxic and can cause skin irritation. When using cleaning solvents, always follow the solvent manufacturer's recommended safety precautions.**

Clean all parts in a cleaning solvent and inspect them carefully. If any parts are damaged or worn, the complete hydraulic valve lifter must be replaced. If the body of the hydraulic valve lifter is worn, also inspect the bore in the engine block. If the bottom of the hydraulic valve lifter is worn or damaged, inspect the camshaft lobe for wear and damage. The bottom of the lifter must be convex for correct rotation during engine operation.

### CYLINDER HEAD, ASSEMBLE

1. Install the valves in their correct ports. See Figure 2. If a spring shim is used, install it on the valve stem. Install the valve spring, oil shield, and valve cap or rotator (exhaust valves) in position on each valve.
2. Use a valve spring compressor to compress the valve spring. Install a new oil seal on each valve stem. Make sure the oil seal is not twisted on the valve stem.
3. Install the retainers for the valve spring assembly. Make sure the retainers fit correctly in the upper groove of the valve stem. Release the spring compressor tool.

### CYLINDER HEAD, INSTALL

1. Clean the surface of the cylinder head and the top of the engine block. The surfaces for the gaskets must be clean. The threads for the head bolts must be clean so that the correct torque is applied during installation.
2. Install a new gasket for the cylinder head to the engine block. Do not use a sealant on the gasket.
3. Carefully install the cylinder head to the engine block. Use a sealant on the capscrews during installation. Tighten the head bolts evenly in a minimum of three steps. Tighten the head bolts evenly to a final torque of 122 N•m (90 lbf ft) in the sequence shown in Figure 9.

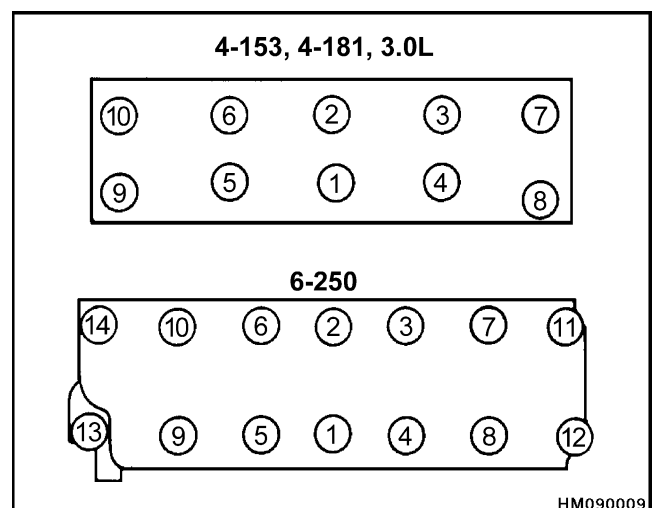

**Figure 9. Cylinder Head Tightening Sequence**

4. If the hydraulic valve lifters (cam followers) were removed, install them in their positions in the engine block. Install the side cover for the hydraulic valve lifters.
  5. Install the push rods in their positions in the engine. Make sure each push rod fits in its socket in its hydraulic valve lifter.
  6. Lubricate the rocker arms and rocker arm balls with engine oil during installation. Install the rocker arms, rocker arm balls, and rocker arm nuts. Tighten the rocker arm nuts until there is zero clearance.
  7. Install the intake manifold and exhaust manifold. Connect the exhaust pipe at the exhaust manifold.
  8. Install the carburetor. Connect the carburetor linkage, fuel line, and hoses.
  9. Install the alternator and bracket.
  10. Install the dipstick tube for engine oil.
  11. Connect the coolant hose to the housing for the thermostat.
  12. Adjust the clearance of the rocker arm assemblies as described in Valve Clearance, Adjust.
- NOTE:** If performing repair on the GM 3.0 liter engine, go to Step 14.
13. When the valve clearances are adjusted correctly, install the rocker arm cover. Use a new gasket between the cylinder head and the rocker arm cover. Install the retaining bolts and tighten them to 6 N•m (50 lbf in).
  14. Install the rocker arm cover as described in Rocker Arm Cover, Install.
  15. Install and connect the PCV valve.
  16. If the distributor cap was removed, install it. Connect the spark plug wires. Connect the wires and hoses fastened to brackets on the rocker arm cover.
  17. Install the air cleaner and component parts.
  18. Fill the cooling system with the correct coolant. See the **Periodic Maintenance** section for your unit.

19. Connect the battery cables at the battery.
20. When the engine can be operated, adjust the ignition timing and carburetor as necessary. See the **Periodic Maintenance** section for additional information.

## VALVE CLEARANCE, ADJUST

1. Remove the cover for the rocker arm assembly.
2. Adjust the valves for each cylinder when the piston is at top dead center on the compression stroke. Use the rotor in the distributor to find top dead center for each piston. Make an identification mark for each cylinder on the distributor housing. Make the marks directly under the connections of the spark plug wires.
3. Remove the distributor cap. Turn the crankshaft until the rotor is aligned over the mark for the number one cylinder. Now adjust both valves for the number one cylinder. Tighten the nut for the rocker arm while turning the push rod with your fingers as shown in Figure 10. Tighten the nut just until the movement of the push rod stops. This condition is zero clearance. Now tighten the nut one more turn.

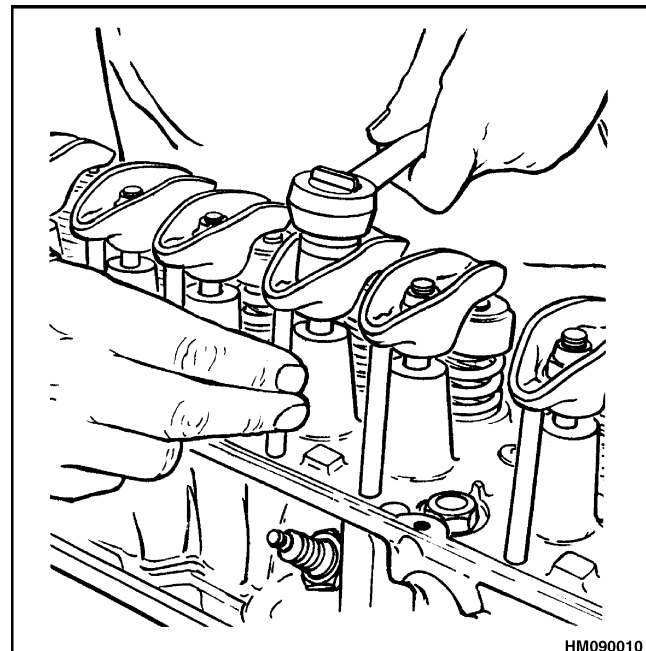

*Figure 10. Valve Clearance Adjustment*

4. Turn the crankshaft in the normal direction of rotation until the rotor aligns over the next mark. (For the six-cylinder engine, the valves for the number five cylinder can now be adjusted. For the four-cylinder engine, the valves for the number three cylinder can now be adjusted.) Adjust the valves as described in Step 3.
5. Follow the same procedure as described in Step 4 until all the valves are adjusted.
6. Install the distributor cap and the cover for the rocker arms.

### ROCKER ARM COVER, INSTALL

1. Remove all gasket material from the cylinder head and the rocker arm cover.
2. Coat the cylinder head rail with Loctite Flange Sealant.

3. Install a new gasket onto the cylinder head rail.
4. Apply Loctite Flange Sealant around the bolt holes of the gasket, and install the rocker arm cover.
5. Tighten the rocker arm cover bolts to 6 N•m (50 lbf in) in the sequence shown in Figure 11.

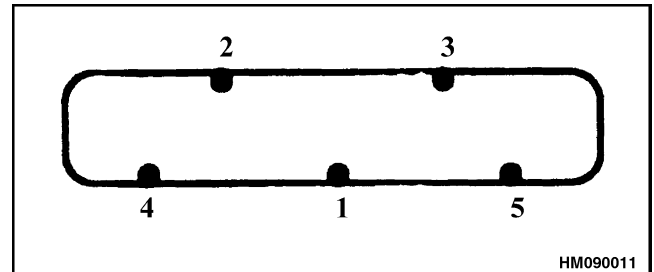

*Figure 11. Rocker Arm Cover Tightening Sequence*

## Timing Gear Cover Repair

### REMOVE

**NOTE:** The oil seal can be replaced without removing the timing gear cover. The crankshaft pulley and vibration dampener must be removed. The oil seal can be removed with a pry bar. Work carefully so that the sheet metal of the timing gear cover is not bent or damaged during removal or installation of the oil seal. The replacement of the oil seal is easier if the timing gear cover is removed from the engine.

1. Drain the coolant system. Remove the radiator.
2. Remove the drive belts. Remove the pulley from the vibration dampener. See Figure 12.

**NOTE:** The vibration dampener on the 3.0L engine is pressed onto the crankshaft. It must be pulled off with a puller.

3. Remove the vibration dampener. Use a tool that pulls on the center of the vibration dampener. (A special tool, GM Part No. J-23523, is available.) See Figure 13. Do not use a puller that pulls on the outside diameter of the vibration dampener.

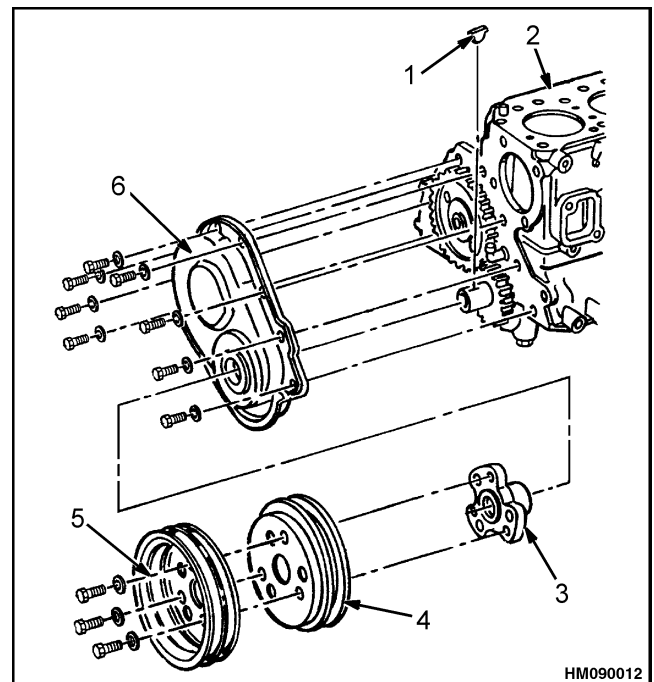

- |                 |                       |
|-----------------|-----------------------|
| 1. WOODRUFF KEY | 4. VIBRATION DAMPENER |
| 2. ENGINE BLOCK | 5. PULLEY             |
| 3. HUB          | 6. TIMING COVER       |

*Figure 12. Timing Gear Cover and Pulleys*

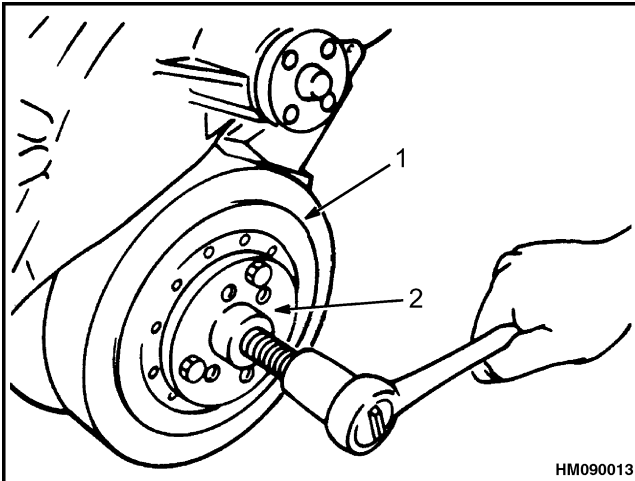

1. VIBRATION DAMPENER
2. TOOL FOR REMOVAL AND INSTALLATION OF VIBRATION DAMPENER

**Figure 13. Vibration Dampener**

4. Remove the screws that hold the oil sump to the timing gear cover. Remove the screws that hold the timing gear cover to the engine block.

**GM 4-153, 4-181 and 3.0L.** Remove the timing gear cover.

**GM 6-250.** Pull the timing gear away from the engine block only enough to cut the front gasket of the oil sump. Use a sharp knife and cut the gasket even with the edge of the engine block. Remove the timing gear cover.

5. Remove the oil seal from the timing gear cover. Do not bend or damage the sheet metal of the timing gear cover when removing the oil seal.

## INSTALL

1. Make sure the gasket surfaces on the engine block, timing gear cover, and oil sump are clean.
2. Install a new oil seal. Carefully press the oil seal into the timing gear cover. Make sure the lip of the oil seal is toward the engine.
3. Install a new gasket if your engine uses a gasket between the timing gear cover and engine block. Apply a thin coat of sealant to both sides of the gasket.
4. Install a centering tool in the oil seal. See Figure 14. (A special tool, GM Part No. J-34995,

is available for GM 4-153, 4-181, and 3.0L, and GM Part No. 23042 is available for GM 6-250.) The oil seal must be aligned so that it is evenly in position around the hub. An oil seal that is not correctly aligned with the hub will be damaged and will leak oil.

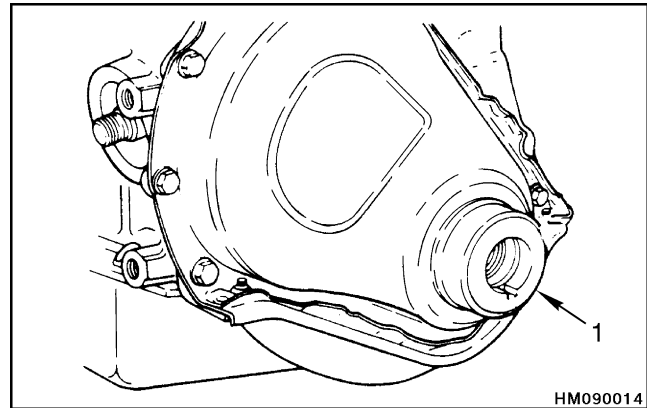

1. CENTERING TOOL

**Figure 14. Timing Gear Cover Centering Tool**

5. **GM 4-153, 4-181, and 3.0L.** Install the timing gear cover. Install the two screws for the oil sump and the screws for the timing gear cover and tighten the screws with your fingers. Make sure the oil seal is correctly aligned. Tighten the screws to 10 N•m (90 lbf in).

**GM 6-250.** Cut the tabs from the oil seal for the front of the oil sump as shown in Figure 15. Apply a thin coat of sealant to both sides of the gasket and put it in position. Apply a 3 mm (1/8 in.) bead of RTV sealant at the joint between the gaskets at the edge of the engine block. Install the timing gear cover. Install the screws for the oil sump and the screws for the timing gear cover and tighten the screws with your fingers. Make sure the oil seal is correctly aligned. Tighten the screws to 9 N•m (80 lbf in).

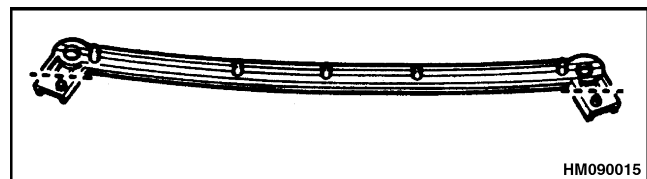

**Figure 15. Front Oil Sump Seal Modification, GM 6-250**



6. Remove the centering tool.

**NOTE:** The vibration dampener on the 3.0L engine is pressed on to the crankshaft and does not use a capscrew.

7. Install the vibration dampener. Use a tool that presses on the center of the vibration dampener. (A special tool, GM Part No. J-23523, is available.) See Figure 13. Do not use a tool that pushes on the outside diameter of the vibration dampener. Make sure the hub of the

vibration dampener is against the crankshaft gear. Tighten the capscrew for the vibration dampener. See Torque Specifications.

8. When used, install the pulley on the vibration dampener. Tighten the capscrews to 44 N•m (32 lbf ft). Install the drive belts.
9. If the coolant system is complete, fill the system with coolant and check for leaks.

## Camshaft Repair

### REMOVE

**NOTE:** The engine is removed from the lift truck for this procedure.

1. Remove the drive belts, fan, and pulley.
2. Remove the timing gear cover. See the procedure under Timing Gear Cover Repair, Remove.
3. Remove the rocker arms and push rods as described in Cylinder Head, Disassemble. Put the parts in a rack so that they will be installed again in the same position.
4. Remove the side cover for access to the hydraulic valve lifters. Remove the hydraulic valve lifters and put them in a rack so that they will be installed again in the same position in the engine block.
5. Remove the fuel pump.
6. Align the timing marks on the timing gears as shown in Figure 16. On engines with holes in the timing gear, remove the two capscrews that hold the thrust plate to the engine block. On engines with a capscrew for the timing gear, remove the capscrew and the gear. Remove the two capscrews for the thrust plate.
7. Carefully pull the camshaft from the engine block. Give enough support to the camshaft so that the bearings are not damaged.

### INSPECT

Measure the amount of clearance between the thrust plate and the camshaft as shown in Figure 17. If the clearance is greater than 0.203 mm (0.008 in.), replace the thrust plate.

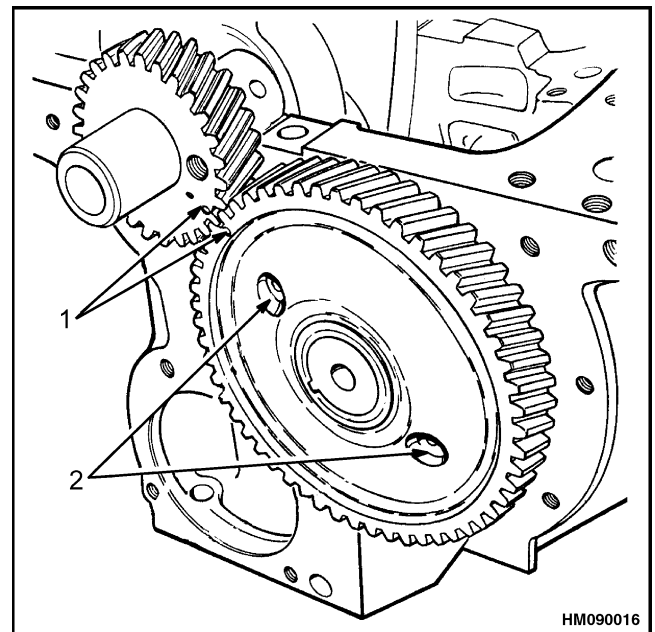

1. TIMING MARKS
2. CAPSCREWS FOR THRUST PLATE

**Figure 16. Timing Gears**

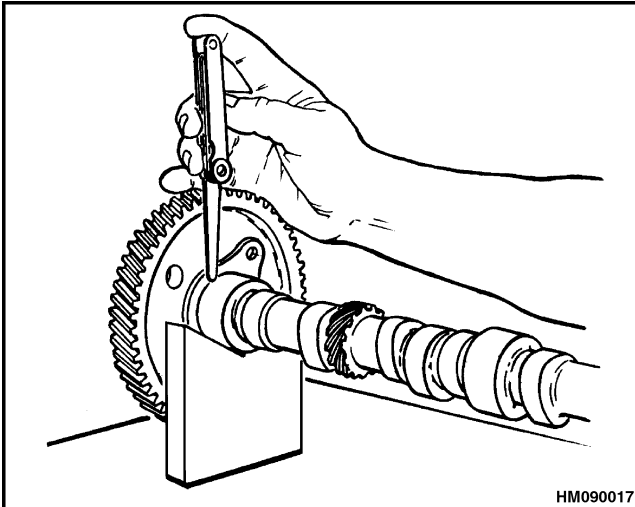

**Figure 17. Thrust Plate and Camshaft Clearance Check**

If the camshaft gear or the thrust plate must be replaced, the camshaft gear must be removed. A press must be used to remove and install the camshaft gear on the camshaft.

**CAUTION**

Make sure the force is applied to the hub of the camshaft gear or the camshaft gear will be damaged. Make sure the Woodruff key does not damage the thrust plate during removal or installation.

Check the surfaces of the camshaft for wear and damage. See the Engine Specifications, Camshaft.

## CAMSHAFT BEARING

### Remove

Special tools are required to remove and install the camshaft bearings. See Figure 18. Remove the front and rear bearings last.

1. Remove the plug in the bore for the camshaft at the rear of the engine block.
2. Install the removal and installation tool as shown in Figure 18. Remove the intermediate bearings.
3. Install the head of the special tool on the end of a driver. Remove the front and rear bearings by pushing them toward the center of the engine block. See Figure 19.

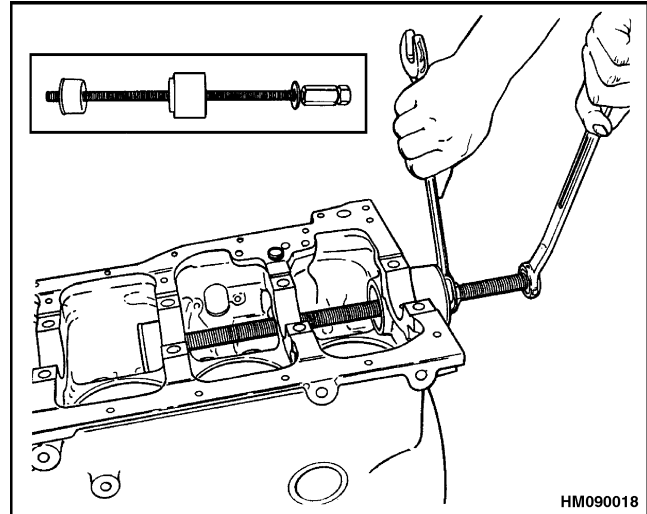

**Figure 18. Camshaft Bearings Replacement**

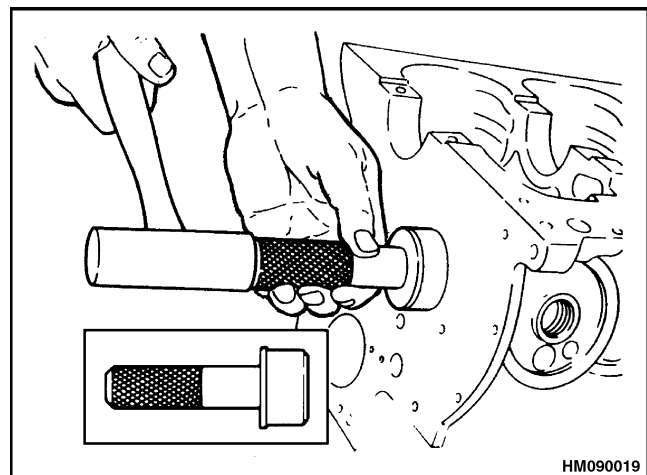

**Figure 19. Camshaft Bearings Replacement**

### Install

**CAUTION**

The holes for the oil passages in the camshaft bearings must be aligned with the oil passages in the bore of the engine block. If the oil passages are not aligned correctly, the loss of lubrication will cause a failure of the camshaft bearings or other parts of the engine.

1. Install the front and rear camshaft bearings first. These bearings will be guides for installation of the intermediate bearings. See Figure 19. Use the special tool to install the front and rear camshaft bearings.

**GM 4-153, 4-181 and 3.0L.** The front camshaft bearing must be 3.0 mm (0.12 in.) below the surface of the engine block so that the oil passage to the nozzle for the timing gears is open.

2. Install the intermediate camshaft bearings. Use the special tool as shown in Figure 18.

3. Install a new plug in the bore in the rear end of the engine block. The surface of the plug must be even with the surface of the engine block or not greater than 0.80 mm (0.03 in.) below the surface.

## Distributor Repair

### REMOVE

**NOTE:** This section has only removal and installation procedures for the distributor. The service procedures for the ignition system are found in the following sections:

- **High Energy Ignition System** 2200 SRM 107
- **Microprocessor Spark Timing System (MSTS)** 2200 SRM 463



### CAUTION

**Carefully lift and release the lock tabs on the connectors to the distributor. The lock tabs can be easily broken if too much force is applied with a screwdriver or other tool.**

**Never let the TACH CONN. terminal touch a ground. The HEI module or the ignition coil will be damaged.**

1. Disconnect the battery negative (ground) cable.
2. If removal of the spark plug wires are not required for the repairs, leave them connected to the distributor cap. Remove the two capscrews that fasten the distributor cap to the distributor. Move the distributor cap away from the work area.
3. Disconnect the distributor 4-terminal connector.
4. Disconnect the ignition coil connector.
5. Remove the bolt and clamp that hold the distributor in the engine. Make a note of the positions of the rotor to distributor housing and the distributor to the engine. Slowly pull the distributor from the engine until the rotor just stops turning counterclockwise and make a note of the position of the rotor. This position must be used when the distributor is installed again.

If the engine has been rotated after the distributor was removed, the following procedure must be used before the distributor is installed again:

- a. Remove the No. 1 spark plug.
- b. Put a finger over the No. 1 spark plug hole and slowly rotate the engine until pressure is felt on the compression stroke.
- c. Align the timing mark on the crankshaft pulley to 0° (TDC) on the engine timing indicator.
- d. Turn the distributor rotor to point between the positions on the distributor cap for No. 1 and No. 4 (or No. 1 and No. 6 for six cylinders) spark plug wires.
- e. Install the distributor in the engine. The rotor and shaft will rotate a few degrees when the gear on the distributor shaft engages the drive gear on the engine cam. The timing is correct if the rotor points at the position on the distributor cap for the No. 1 spark plug wire.
- f. Continue with the installation of the distributor as described in Install.

### INSTALL

1. Put the rotor and distributor in the same position as it was removed from the engine.
2. Install the clamp and bolt. Tighten the bolt with your hand.
3. Install the distributor connector(s) at the distributor.
4. Install the ignition coil connector.
5. Install the distributor cap and the two capscrews. If the spark plug wires were removed, install them in the correct sequence.
6. Connect the battery negative cable.

7. Start the engine and check the engine timing. See the section for **Periodic Maintenance** for your lift truck for procedures on Ignition Timing.
8. Tighten the bolt for the distributor clamp. See Torque Specifications.

## Lubrication System Repair

### OIL SUMP

#### Remove

1. Disconnect the battery negative (ground) cable.
2. Remove the dipstick. Drain the engine oil.
3. Remove the starter.
4. Remove the bolts that fasten the oil sump to the engine block. Remove the oil sump.

#### Install

1. Clean the sealing surfaces on the oil sump and the engine block. Remove old gasket material or sealant.

**NOTE:** Some engines use a gasket to seal the joint between the oil sump and the engine block. Earlier production engines use a two-piece gasket and separate rear oil seal for the crankshaft. Some later production engines use a one-piece gasket. If a gasket is used in your engine, apply a thin coat of liquid sealant to the gasket surfaces to hold it in position on the oil sump during installation. Other later production engines use an RTV sealant between the oil sump and the engine block. If your engine uses only an RTV sealant, apply a 3.0 mm (0.12 in.) bead of sealant around the sealing surfaces of the oil sump.

2. Apply RTV sealant or install the gasket on the oil sump.
3. Install the capscrews that fasten the oil sump to the engine block. Tighten the 1/4 - 20 capscrews to 10 N•m (7 lbf ft). Tighten the 5/16 - 18 capscrews to 19 N•m (14 lbf ft).

### OIL PUMP

#### Remove

1. Remove the oil sump.
2. Remove the mount bolts and remove the oil pump and screen assembly.

#### Disassemble and Repair

1. Disassemble the oil pump as necessary for cleaning and inspection. Remove the four screws that fasten the cover to the pump body. Remove the cover and gasket. See Figure 20.

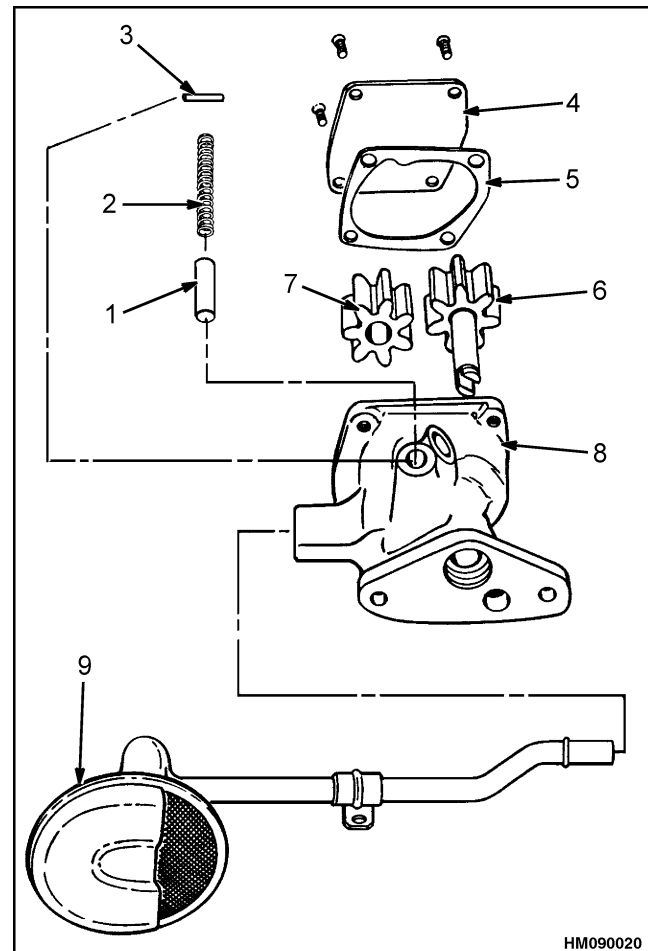

- |                 |               |
|-----------------|---------------|
| 1. RELIEF VALVE | 6. DRIVE      |
| 2. SPRING       | 7. IDLER GEAR |
| 3. PIN          | 8. PUMP BODY  |
| 4. COVER        | 9. SCREEN AND |
| 5. GASKET       | TUBE ASSEMBLY |

*Figure 20. Oil Pump*

2. Make an index mark on the gears so that they can be installed again in the same position to each other. Remove the gears. Do not remove the screen and tube assembly unless it is damaged.



### WARNING

**The relief valve has a compressed spring. When the pin is removed, do not permit a sudden release of the spring and cause an injury.**

3. Remove the pin, spring, and the relief valve.
4. Inspect the gears and the pump body for wear and damage. If the parts are worn or damaged, replace the oil pump. Parts are not available for repairs.

### Assemble

**NOTE:** Use a sealant when replacement of the screen and tube assembly is necessary. Do not damage the tube during installation. Make sure that the surface

## Piston and Connecting Rod Assemblies Repair

of the screen assembly is parallel to the bottom surface of the engine block.

1. If the relief valve was disassembled, install the relief valve, spring, and pin. See Figure 20.
2. Install the gears in the pump body. Align the identification marks. Make sure that the smooth side of the idler gear is toward the cover.
3. Use a new gasket and install the cover. Tighten the screws to 8 N•m (71 lbf in). Turn the drive shaft with your hand to check for a smooth operation.

### Install

1. Install the oil pump and screen assembly. Make sure the screen is parallel to the bottom of the oil sump when the oil pump is installed.
2. Install the oil sump.

## Piston and Connecting Rod Assemblies Repair

### CONNECTING ROD BEARINGS, REPLACE

**NOTE:** The connecting rod bearings are available in a standard size and several undersizes. See the Parts Manual for bearing sizes. If a bearing on a journal is worn, both the upper and lower half of the bearing must be replaced.

1. Remove the oil sump and the oil pump.
2. Before the cap for the connecting rod is removed, mark the connecting rod and cap with the cylinder number so that the parts will be installed again in their original positions. Remove the cap for the connecting rod bearing and the lower bearing half.
3. Push the connecting rod away from the crankshaft and remove the upper bearing half. Wipe the oil from the bearing halves and the bearing journal.
4. Use a micrometer to measure the bearing journal. The bearing journal must be within the following specifications:  
Four-cylinder engines:

Out-of-round less than 0.0127 mm  
(0.0005 in.)

Taper less than 0.0127 mm (0.0005 in.)

Six-cylinder engines

Out-of-round less than 0.0254 mm  
(0.001 in.)

Taper less than 0.0254 mm (0.001 in.)

If the bearing journals are not within specifications, the crankshaft must be removed and the bearing journal ground to an undersize. If the bearing journal cannot be repaired so that the bearing journal is a correct undersize, the crankshaft must be replaced. See Engine Specifications, Crankshaft.

5. If the bearing journal is within specifications, measure the clearance between the new bearing and the crankshaft. Use Plastigage® or equivalent to check the clearance.
  - a. Put a piece of Plastigage across the full width of the bearing journal as shown in Figure 21. Do not rotate the crankshaft when the Plastigage is between the bearing and its journal.