

1. Trim along dashed line.
2. Slide into pocket on Binder Spine.

TYPE 1-4

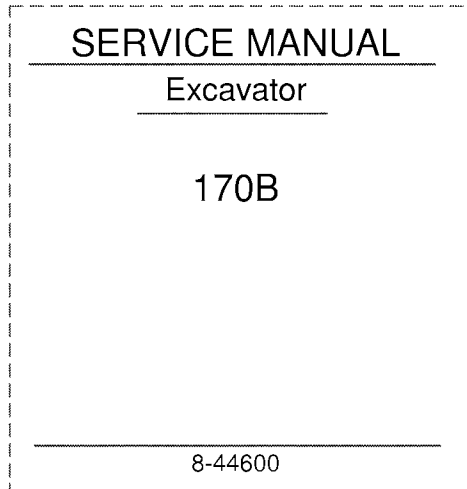

1. Trim along dashed line.
2. Slide into pocket on Binder Spine.

TYPE 1-4

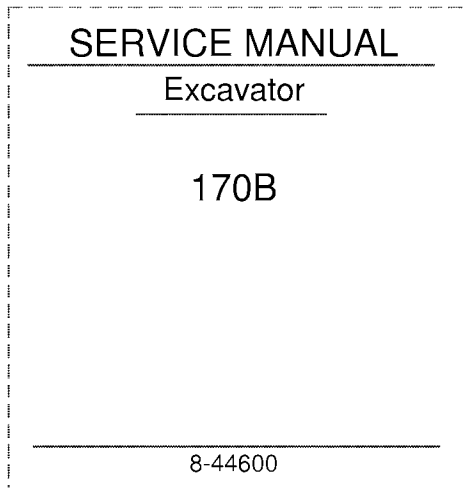

1. Trim along dashed line.
2. Slide into pocket on Binder Spine.

TYPE 1-4

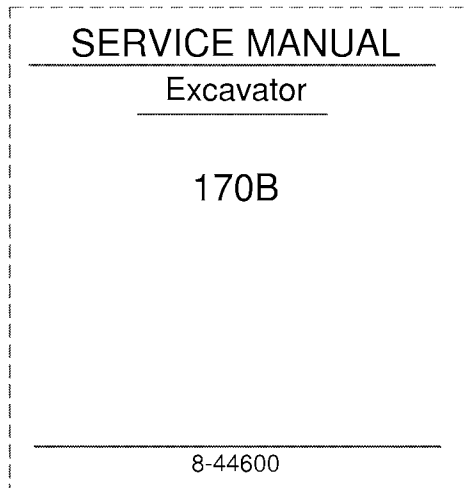

1. Trim along dashed line.
2. Slide into pocket on Binder Spine.

TYPE 1-4

170B EXCAVATOR TABLE OF CONTENTS

DIVISION/SECTION	SECTION NO.	FORM NO.
1 GENERAL		
Safety Rules, Service Manual Introduction, and Torque		
Specifications	1001	8-43910
Maintenance and Lubrication	1002	8-44600
2 ENGINES		
Engine Removal and Installation	2000	8-44600
Engine Accessories	2001	8-44600
Deutz Engine Service Manual		291-1842
3 FUEL SYSTEM		
Fuel Lines, Fuel Tank, and Engine Controls	3001	8-44600
4 ELECTRICAL		
Electrical System Specifications and Troubleshooting	4002	8-44600
Wiring Schematics	4003	8-44600
Batteries	4005	8-43910
Starter	4006	8-43910
Alternator	4007	8-43910
5 TRACK AND SUSPENSION		
Removal and Installation of Track Components	5501	8-44600
Troubleshooting	5502	8-43910
Track Chain and Shoes	5503	8-44600
Track Rollers, Carrier Rollers, Idlers, and Sprockets	5506	8-44600
6 POWER TRAIN		
Removal and Installation of Power Train Components	6301	8-44600
Drive Motor	6312	8-44600
Final Drive Transmission	6317	8-44600
8 HYDRAULICS		
Removal and Installation of Hydraulic Components	8200	8-44600
Maintenance and Service	8201	8-44600
Specifications and Troubleshooting	8202	8-44600
Low Pressure Hydraulic Pump	8204	8-44600
Main Hydraulic Pump	8205	8-44600
Attachment Control Valve	8206	8-43910
Swing and Drive Control Valve	8207	8-43911
Control Valve for Options	8208	8-43910
Hand Control Valves and Foot Control Valves	8209	8-43910
Solenoid Control Valves	8210	8-44600
Parallel Supply Control Valve for the Arm Circuit	8211	8-43910
Power Sensing Valve	8212	8-43910
Pressure Regulator Valves	8213	8-44600
Swing Motor	8215	8-43911
Oil Cooler Motor	8217	8-43910
Hydraulic Swivel	8218	8-43910
Cylinders	8290	8-44600

DIVISION/SECTION

SECTION NO.

FORM NO

9 MOUNTED EQUIPMENT

Boom, Arm, and Tool	9211	8-44600
Turntable Bearing and Related Parts	9216	8-44600

REAR POCKET

Electrical Schematic		850451A
Location Schematic		850450A
Hydraulic Schematic		851904

1001

SAFETY RULES, SERVICE MANUAL INTRODUCTION, AND TORQUE SPECIFICATIONS

TABLE OF CONTENTS

Safety Rules	1001-2
Service Manual Introduction	1001-4
Torque Specifications - Metric Hardware	1001-5
Torques for Hydraulic Fittings	1001-6

Written In *Clear
And
Simple
English*

**Thanks very much for your reading,
Want to get more information,
Please click here, Then get the complete
manual**

JustClickHere 

NOTE:

**If there is no response to click on the link above,
please download the PDF document first, and then
click on it.**

**Have any questions please write to me:
admin@servicemanualperfect.com**

SAFETY RULES

 This symbol means **ATTENTION! BECOME ALERT! YOUR SAFETY IS INVOLVED.** The message that follows the symbol contains important information about safety. Carefully read the message. Make sure you fully understand the causes of possible injury or death. 1-1-C

NOTE: To prevent injury on job, follow the Warning, Caution, and Danger notes in this section and other sections throughout this manual. Follow the instructions carefully.

The procedures recommended and shown in this manual are good, effective service methods. However, all possible procedures and service hazards may not be covered. Therefore, if you use a tool or procedure not recommended, you must make sure that the method you select is a safe method.

Put the warning tag shown below on the key for the key switch when you are servicing or repairing this machine. One warning tag is on every new machine. You can buy additional warning tags, part number 331-4614, from Service Parts Supply.



 **WARNING:** This is a one man machine, no riders allowed. 35-8

 **WARNING:** Before starting engine, study operator's manual safety messages. Read all safety signs on machine. Clear the area of other persons. Learn and practice safe use of controls before operating.

It is your responsibility to understand and follow manufacturer's instructions on machine operation, service, and to observe pertinent laws and regulations. Operator's and service manuals may be obtained from your J I Case dealer.

45-2

 **WARNING:** If you wear clothing that is too loose or do not use the correct safety equipment for your job, you can be injured. Always wear clothing that will not catch on objects. Extra safety equipment that can be required includes hard hat, safety shoes, ear protection, eye or face protection, heavy gloves and reflector clothing.

45-3-A

 **WARNING:** Read operator's manual to familiarize yourself with control lever functions.

46-27

 **WARNING:** Operate tractor and equipment controls from the seat position only. Any other method could result in serious injury.

48-55

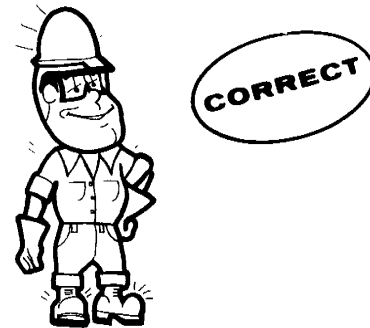

 **WARNING:** When working in the area of the fan belt with the engine running, avoid loose clothing if possible, and use extreme caution.

35-4



WARNING: When doing checks and tests on the equipment hydraulics, follow the procedures as they are written. **DO NOT** change the procedure. 47-44



WARNING: When putting the hydraulic cylinders on this machine through the necessary cycles to check operation or to remove air from a circuit, make sure all people are out of the way. 47-45



WARNING: Use insulated gloves or mittens when working with hot parts. 47-41A



CAUTION: Lower all attachments to the ground or use stands to safely support the attachments before you do any maintenance or service. 49-11



CAUTION: Pin sized and smaller streams of hydraulic oil under pressure can penetrate the skin and result in serious infection. If hydraulic oil under pressure does penetrate the skin, seek medical treatment immediately. Maintain all hoses and tubes in good condition. Make sure all connections are tight. Make a replacement of any tube or hose that is damaged or thought to be damaged. **DO NOT** use your hand to check for leaks; use a piece of cardboard or wood. 40-6-A



CAUTION: When removing hardened pins such as a pivot pin, or a hardened shaft, use a soft head (brass or bronze) hammer or use a driver made from brass or bronze and a steel head hammer. 46-17



CAUTION: When using a hammer to remove and install pivot pins or separate parts, using compressed air or using a grinder, wear eye protection that completely encloses the eyes (approved goggles or other approved eye protectors). 46-13



CAUTION: When servicing or repairing the machine, keep the shop floor and operator's compartment and steps free of oil, water, grease, tools, etc. Use an oil absorbing material and/or shop cloths as required. Use safe practices at all times. 40-8



CAUTION: Use suitable floor (service) jacks or chain hoists to raise wheels or track off the floor. Always block machine in place with suitable safety stands. 40-7-A



CAUTION: Some components of this machine are very heavy. Use suitable lifting equipment or additional help as instructed in this service manual. 40-10



DANGER: Engine exhaust fumes can cause death. If it is necessary to start the engine in a closed place, remove the exhaust fumes from the area with an exhaust pipe extension. If you do not have an exhaust pipe extension, open the doors and get outside air into the area. 48-56

SERVICE MANUAL INTRODUCTION

This service manual has been prepared with the latest service information available. Troubleshooting, removal, disassembly, inspection and installation procedures, and complete specifications and tightening references can be found in most sections. Some sections have drawings but no written procedure because the job is so easily done. This service manual is one of the most important tools available to the service technician.

Right, Left, Front, and Rear

The terms right-hand and left-hand and front and rear as used in this manual indicate the right and left sides, and front and rear of the machine as seen from the operator's seat for correct operation of the machine or attachment.

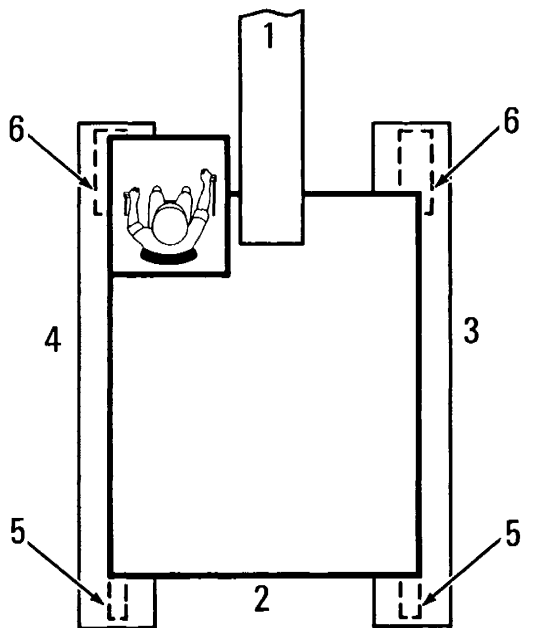

- | | |
|---------------|-------------------|
| 1. Front | 4. Left Side |
| 2. Rear | 5. Drive Sprocket |
| 3. Right Side | 6. Idler Wheel |

831128 A

Table of Contents

A Table of Contents is in the front of this manual. The Table of Contents shows the main divisions and the sections that are in each division. The individual sections, also have a Table of Contents.

Page Numbers

All page numbers are made of two numbers separated by a dash, such as 4002-9. The number before the dash is the section number. The number following the dash is the page number in that section. Page numbers will be found at the upper right or left of each page.

Illustrations

Illustrations are put as near as possible to the text and are to be used as part of the text.

Clear and Simple English

This manual is written in C.A.S.E. (Clear and Simple English). C.A.S.E. is easier to read than "regular" English because C.A.S.E. uses a small number of common words and has special rules for writing.

All sections written in C.A.S.E. are indicated by the symbol below.

Written In <i>Clear And Simple English</i>
--

Special Tools

Special tools are needed to remove and install, disassemble and assemble, check and adjust some component parts of this machine. Some special tools can be easily made locally and the necessary information to make the tool is in this service manual. Other special tools are more difficult to make locally and are available from Service Tools in the U.S. and from Jobborn Manufacturing in Canada. Use these tools according to the instructions in this service manual for your personal safety and to do the job correctly.

Order special tools from either of the following companies.

Service Tools
P.O. Box 314
Owatonna, Minnesota 55060

Jobborn Manufacturing Co.
97 Frid Street
Hamilton, Ontario L8P 4M3
Canada

TORQUE SPECIFICATIONS - METRIC HARDWARE

Use the following torques when special torques are not given.

These values apply to fasteners with coarse threads as received from supplier, plated or unplated, or when lubricated with engine oil. These values do not apply if graphite or moly-disulfide grease or oil is used.

Grade 8.8 Bolts, Nuts, and Studs			
			
Size	Pound-Feet	Newton metres	Kilogram metres
M4 0.15 in	2-3	3-4	0.3-0.4
M5 0.19 in	5-6	6.5-8	0.7-0.8
M6 0.23 in	8-9	10.5-12	1.1-1.2
M8 0.31 in	19-23	26-31	2.6-3.2
M10 0.39 in	38-45	52-61	5.3-6.2
M12 0.46 in	66-79	90-107	9.1-10.9
M14 0.55 in	106-127	144-172	14.7-17.6
M16 0.62 in	160-200	217-271	22.1-27.7
M20 0.78 in	320-380	434-515	44.2-52.5
M24 0.94 in	500-600	675-815	69.1-83.0
M30 1.17 in	920-1100	1250-1500	127-152
M36 1.40 in	1600-1950	2175-2600	221-270

Grade 10.9 Bolts, Nuts, and Studs			
			
Size	Pound-Feet	Newton metres	Kilogram metres
M4 0.15 in	3-4	4-5	0.4-0.5
M5 0.19 in	7-8	9.5-11	1.0-1.1
M6 0.23 in	11-13	15-17.5	1.5-1.8
M8 0.31 in	27-32	37-43	3.7-4.4
M10 0.39 in	54-64	73-87	7.5-8.8
M12 0.46 in	93-112	125-150	12.9-15.5
M14 0.55 in	149-179	200-245	20.6-24.7
M16 0.62 in	230-280	310-380	31.8-38.7
M20 0.78 in	450-540	610-730	62.2-74.7
M24 0.94 in	780-940	1050-1275	108-130
M30 1.17 in	1470-1770	2000-2400	203-245
M36 1.40 in	2580-3090	3500-4200	357-427

Grade 12.9 Bolts, Nuts, and Studs



Usually the torque values specified for grade 10.9 fasteners can be used satisfactorily on grade 12.9 fasteners.

TORQUES FOR HYDRAULIC FITTINGS

Unions and Connections (Hoses)	Torque
13 mm	22 pound-feet (30 N m, 3 kg/m)
17 mm	40 pound-feet (55 N m, 5.5 kg/m)
21 mm	72 pound-feet (100 N m, 10 kg/m)
27 mm	144 pound-feet (200 N m, 20 kg/m)
34 mm	202 pound-feet (280 N m, 28 kg/m)
42 mm	275 pound-feet (380 N m, 38 kg/m)
49 mm	108 pound-feet (150 N m, 15 kg/m)

Tube Nuts		Torque	
ID	OD	High Pressure	Low Pressure
5 mm	10 mm	32 pound-feet (45 N m, 4.5 kg/m)	22 pound-feet (30 N m, 3 kg/m)
12 mm	17 mm	61 pound-feet (85 N m, 8.5 kg/m)	51 pound-feet (70 N m, 7 kg/m)
15 mm	21 mm	116 pound-feet (160 N m, 16 kg/m)	87 pound-feet (120 N m, 12 kg/m)
20 mm	27 mm	206 pound-feet (285 N m, 28.5 kg/m)	108 pound-feet (150 N m, 15 kg/m)
26 mm	34 mm	333 pound-feet (460 N m, 46 kg/m)	108 pound-feet (150 N m, 15 kg/m)

Flanges	Torque
17 mm	13 pound-feet (18 N m, 1.8 kg/m)
21 mm	20 pound-feet (28 N m, 2.8 kg/m)
27 mm	40 pound-feet (55 N m, 5.5 kg/m)
34 mm	64 pound-feet (88 N m, 8.8 kg/m)
42 mm	101 pound-feet (140 N m, 14 kg/m)
49 mm	64 pound-feet (88 N m, 8.8 kg/m)
(low pressure)	
50 mm	152 pound-feet (210 N m, 21 kg/m)

1002

MAINTENANCE AND LUBRICATION

TABLE OF CONTENTS

Systemgard™ Testing Schedule	1002-2	Maintenance Schedule	1002-3
Run-In Period	1002-2	Fluids and Lubricants Chart	1002-5
Run-In Maintenance Schedule	1002-2		

SYSTEMGARD™ TESTING SCHEDULE

Get samples of lubricants for Systemgard™ analysis at the intervals shown below. Follow the instructions with the Systemgard™ kits.

	Every 100 hours of operation	Every 500 hours of operation (at least three times yearly)
Engine	X	
Hydraulic System		X
Final Drive Transmission		X

RUN-IN PERIOD

During the first 20 hours of operation for a new machine, or a machine with a rebuilt engine, make sure you do the following:

1. Operate the machine with normal loads for the first 8 hours.
2. Keep the engine at normal operating temperatures.
3. Do not run the engine at idle speeds for long periods of times.
4. See the Run-In Maintenance Schedule on this page for additional information.

RUN-IN MAINTENANCE SCHEDULE

The following items are to be done during the Run-In Period and are in addition to the items in the Maintenance Schedule on the following page.

————— **After First 20 Hours of Operation** —————

Do the After Delivery Check See the Operators Manual

————— **After First 100 Hours of Operation** —————

Tighten track shoe bolts See Section 5503

Tighten all high pressure fittings See Section 1001



WARNING: *When you adjust or service the machine, always follow the instructions in the operator's or service manual. If the engine must be running, always have an extra person help you. Do not leave the operator's seat while the engine is running. Failure to follow these instructions can cause injury.*

47-51-A

MAINTENANCE SCHEDULE

The items in this maintenance schedule are at maximum intervals. If you are operating the machine under severe conditions (high temperatures, mud, dust, water, etc.), shorten the intervals.

AS REQUIRED

Check track tension	See Section 5503
Service air cleaner if restriction indicator lamp illuminates	See Section 2001
Replace hydraulic filter elements if warning lamp illuminates	See Section 8201

Every 10 Hours of Operation or Each Day, Whichever Occurs First

Check the engine oil level	See Operators Manual
Check hydraulic reservoir fluid level	See Section 8201
Clean air cleaner dust valve	See Section 2001
Check the condition of the drive belts	See Operators Manual
Check and clean safety decals	See Operators Manual
Lubricate turntable ring gear	See Operators Manual
Lubricate boom, arm, and tool pivot points	See Operators Manual
Drain water and sediment from fuel tank	See Operators Manual
Fill fuel tank	See Operators Manual

Every 50 Hours of Operation

Lubricate turntable bearing race (4 fittings)	See Operators Manual
Lubricate starter ring gear and pinion	See Operators Manual

Every 100 Hours of Operation

Systemgard™ testing schedule	See Page 1002-2
Clean sediment bowl screen	See Operators Manual
Clean hydraulic cooler	See Section 8201
Check track tension	See Section 5503
Check alternator drive belt tension	See Operators Manual
Clean swing system ring gear	See Operators Manual
Clean engine, oil cooler, and cooling fins	See Operators Manual
Change engine oil	See Operators Manual
Check fluid level for batteries	See Section 4005

Every 200 Hours of Operation

- Check final drive transmission oil level See Operators Manual
- Clean batteries See Operators Manual
- Replace engine fuel filter element See Operators Manual
- Check engine valve clearance See Deutz Engine Manual
- Check track pad mounting bolts torque See Section 5503
- Tighten all loose hydraulic fittings See Section 1001

Every 500 Hours of Operation

- Systemgard™ testing schedule See Section 8201
- Replace hydraulic filter elements See Section 8201

Every 1000 Hours of Operation

- Check injectors See Deutz Engine Manual
- Replace hydraulic fluid reservoir breather filter element See Section 8201
- Check alternator See Section 4002
- Check starter See Section 4002

Every 2000 Hours of Operation or Each Year, Whichever Occurs First

- Check injection pump See Deutz Engine Manual
- Replace cooling fan drive belts See Operators Manual
- Drain the hydraulic system and fill with new fluid See Section 8201
- Change oil for final drive transmission See Operators Manual

FLUIDS AND LUBRICANTS CHART

Fuel tank

Capacity 108 U.S. gallons (410 litres)
 Specifications See Operators Manual

Engine crankcase

Capacity - Without filter change 18 U.S. quarts (17 litres)
 With filter change 19.1 U.S. quarts (18 litres)
 Specifications Case HDM

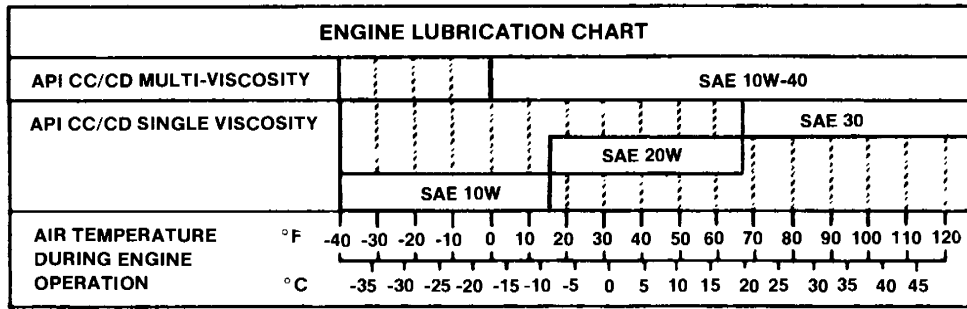

850983

Hydraulic system

Capacity - Reservoir 79 U.S. gallons (300 litres)
 Complete system 105.6 U.S. gallons (400 litres)
 Specifications Tennco EX 745
 Case part number S118631
 (55 U.S. gallons, 208 litres)

Final drive transmission

Capacity - each 5.3 U.S. quarts (5 litres)
 Specifications Case FDL Gear Lubricant
 Alternate SAE 85/140 API GL-5

Turntable ring gear

Specifications See Operators Manual

Starter ring gear teeth and pinion

Specifications See Operators Manual

Batteries

Specifications Drinking or distilled water

Grease fittings

Specifications Case molydisulfide grease

2000

ENGINE REMOVAL AND INSTALLATION

TABLE OF CONTENTS

Engine Removal	2000-2
Engine Installation	2000-3

ENGINE REMOVAL

Before you disconnect any hoses, put identification tags on the hoses. Install plugs and caps in the hoses and fittings to keep dirt out of the engine.

1. Put the battery disconnect switch in the OFF position.

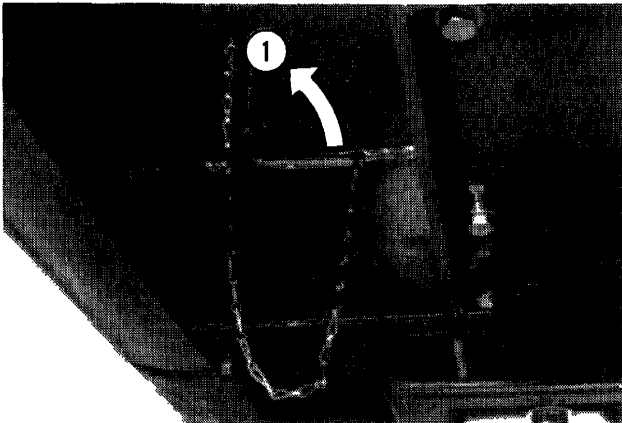

1. OFF Position

856683

2. Loosen and remove the cap screws, flat washers, and spacers that fasten the cowling to the upper structure.
3. Close the doors on the cowling.
4. Connect lifting equipment to the cowling.
5. Remove the cowling from the machine.

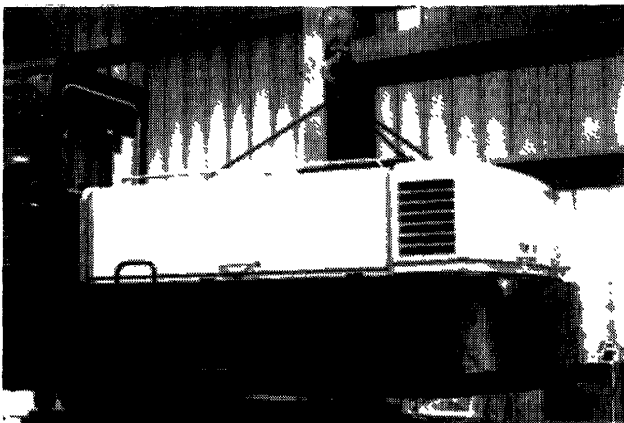

A855026

6. Loosen the two screws that fasten the coupling to the low pressure hydraulic pump.

7. Loosen and remove the self-locking nuts, washers, and bolts that fasten the low pressure hydraulic pump to the mounting plate.

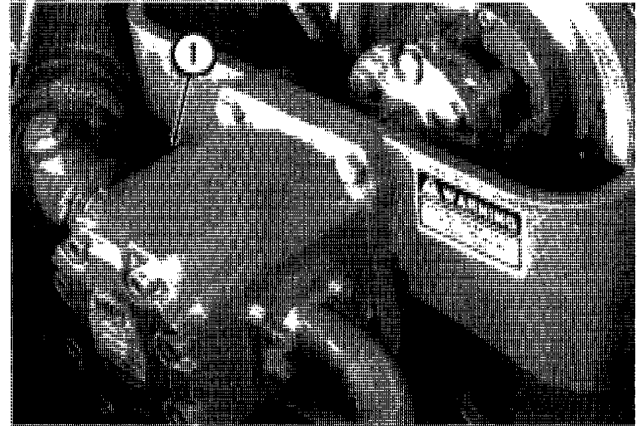

1. Low Pressure Hydraulic Pump

856696

8. Pull the low pressure hydraulic pump away from the mounting plate until the shaft is clear of the mounting plate.
9. Disconnect the air cleaner hose from the turbocharger.
10. Loosen and remove the cap screws and flat washers from the rear engine mounts.
11. Put identification tags on all the electrical wires connected to the engine.
12. Disconnect the wires from all the switches and senders on the engine.
13. Cut the tie straps that fasten the wires to the engine. Move the wires out of the way.
14. Disconnect the battery cable and ground strap from the starter.
15. Disconnect the fuel lines from the engine.
16. Disconnect the hoses for the cab heater from the housing for the engine oil filter.
17. Disconnect the throttle cable and fuel shutoff cable from the fuel injection pump.
18. Disconnect the throttle cable and fuel shutoff cable from the bracket on the engine.
19. Disconnect the heater control cable from the housing for the engine oil filter.

20. Close the shutoff valve on the hydraulic reservoir.

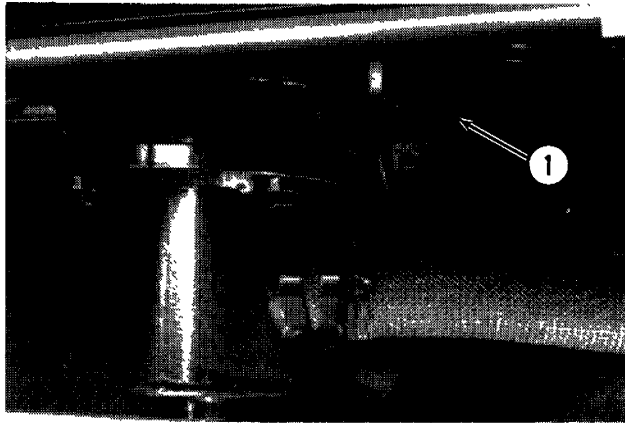

1. Closed

856666

21. Disconnect the hoses from the main hydraulic pump.

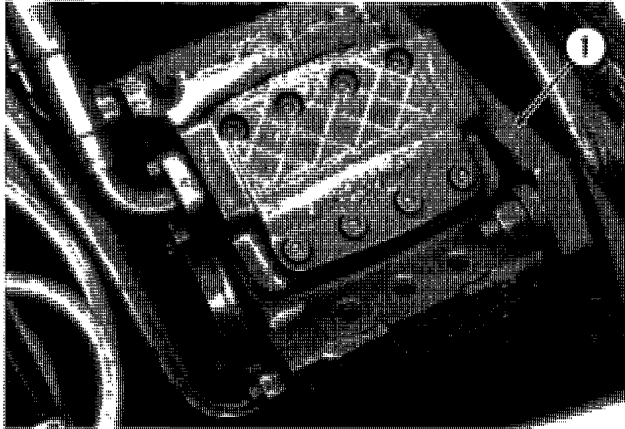

1. Main Hydraulic Pump

856671

22. Connect lifting equipment to the engine. The weight of the engine is approximately 1100 pounds (490 kg).

23. Loosen and remove the cap screws and flat washers from the front engine mount.

24. Slowly raise the engine and check to make sure that all wires and hoses are disconnected from the engine.

25. Remove the engine from the machine.

ENGINE INSTALLATION

1. Connect lifting equipment to the engine.
2. Move the engine into position in the machine.
3. Align the front engine mounts. Install the cap screws and flat washers.
4. Align the rear engine mounts. Install the cap screws and flat washers.
5. Tighten the cap screws for the engine mounts to 44 pound-feet (60 N m, 6 kg/m).
6. Disconnect the lifting equipment from the engine.
7. Connect the hoses to the main hydraulic pump.

8. Open the shutoff valve on the hydraulic reservoir.

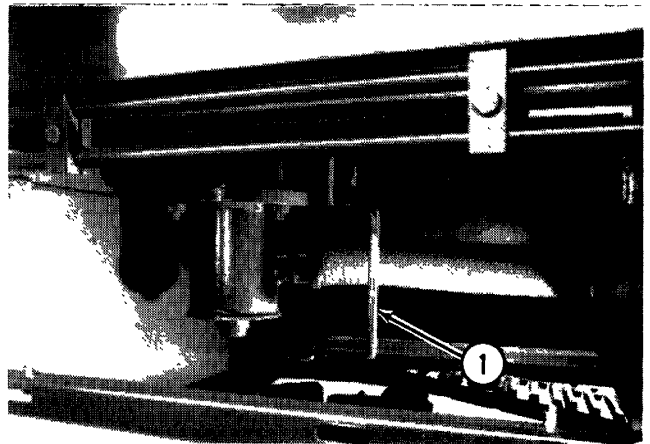

1. Open

856667

9. Connect the heater control cable to the housing for the engine oil filter.

2000-4

10. Connect the throttle cable and fuel shutoff cable to the bracket on the engine.
11. Connect the throttle cable and shutoff cable to the fuel injection pump.
12. Connect the hoses for the cab heater to the housing for the engine oil filter.
13. Connect the fuel lines to the engine.
14. Connect the ground strap and battery cable to the starter.
15. Connect the electrical wires to the switches and senders on the engine.
16. Install tie straps to fasten the wires to the engine.
17. Connect the air cleaner hose to the turbocharger.
18. Align the shaft of the low pressure hydraulic pump with the coupling. Push the low pressure hydraulic pump against the mounting bracket and install the bolts, flat washers, and self-locking nuts.
19. Tighten the screws to fasten the coupling to the shaft of the low pressure hydraulic pump.

20. Connect lifting equipment to the cowling. Install the cowling on the machine.

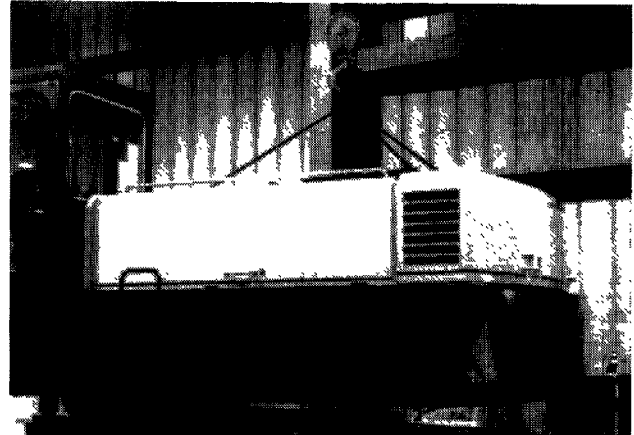

A855026

21. Install the cap screws, flat washers, and spacers to fasten the cowling to the machine.
22. Move the battery disconnect switch to the ON position.

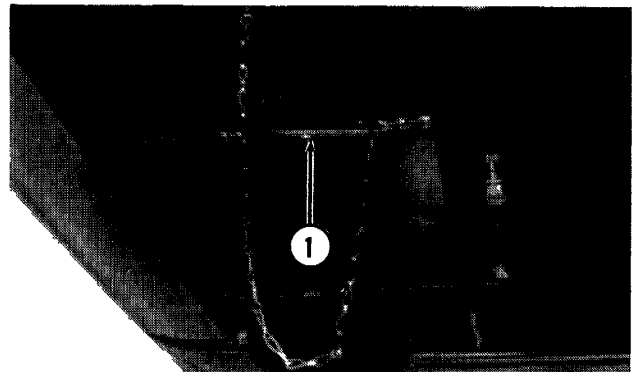

1. ON Position

856683

23. Start and run the engine at idle for two minutes. Stop the engine and check for oil leakage.

2001

ENGINE ACCESSORIES

TABLE OF CONTENTS

Air Cleaner	2001-2	Element Service	2001-2
Restriction Indicator Warning Lamp ...	2001-2	Illustration of Air Cleaner	2001-4
Dust Valve	2001-2	Exhaust System	2001-5
Precleaner Service	2001-2	Illustration of Muffler	2001-5

AIR CLEANER

Restriction Indicator Warning Lamp

You must service the air cleaner if the warning lamp for air cleaner illuminates when the engine is running. It is recommended that you do not run the engine until after you service the air cleaner.

Dust Valve

Clean the dust valve every 10 hours of operation or each day, whichever occurs first.

Remove the dust valve from the dust cup to clean.

Precleaner Service

When you service the air cleaner elements, remove and clean the precleaner.

1. Loosen the clamp and remove the dust cup.
2. Loosen the clamp for the precleaner and remove the precleaner.
3. Use a stiff brush to clean the tubes of the precleaner.
4. Use compressed air or warm water 160°F (70°C) to clean the precleaner.

NOTE: Do not steam clean the precleaner.

Element Service

1. Remove the air cleaner cover.
2. Remove and clean the primary element. See Cleaning Primary Element on page 2001-3. Replace the primary element after cleaning six times.

NOTE: The date of manufacture is on the end cap of the primary element. Do not install a primary element that is more than two years old.

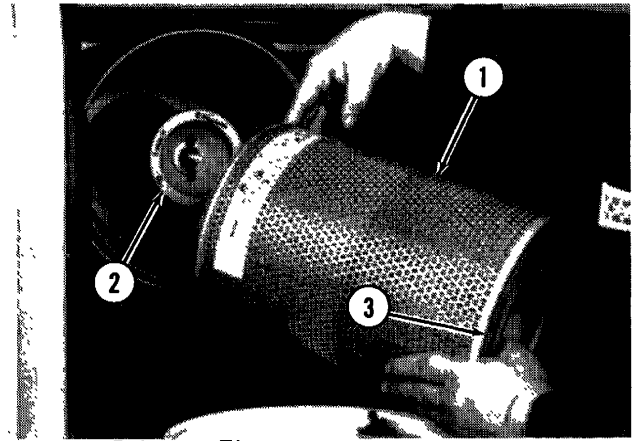

1. Primary Element
2. Secondary Element
3. Date of Manufacture

A846891

3. Check the condition of the secondary element. If the indicator in the wing nut is green, the secondary element is good. If the indicator is red, replace the secondary element. Then make the indicator ready for use again by doing the following steps:

- a. Cover the opening A with your finger.
- b. Blow air in B until the green point appears.

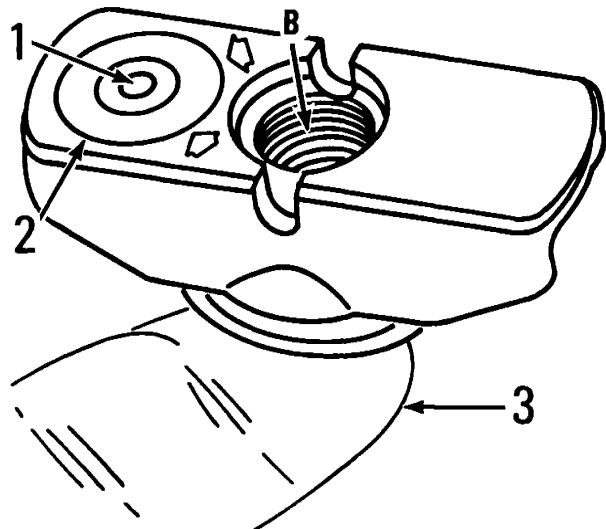

1. Green Point
2. Indicator
3. Finger

851603