

1816, 1816B, AND 1816C UNI-LOADERS

TABLE OF CONTENTS

DIVISION/SECTION	SECTION NO.	FORM NO.
1 GENERAL		
Safety Rules, Service Manual Introduction, and Torque Specifications	1001	8-41040
Maintenance and Lubrication	1002	8-41040
Engine Specifications - 1816C	1003	8-41040
2 ENGINES		
Troubleshooting a Hard Starting Engine and D61880 Starter (Square Housing) - 1816 and 1816B	2001	8-41040
Engine Troubleshooting	2002	8-41040
Engine Removal and Installation - 1816 and 1816B and Drive Belts - 1816	2003	8-41040
Engine Removal Installation, 1816C	2004	8-41040
Tecumseh Engines Mechanic's Handbook - 1816 and 1816B		691462A
Onan Engine - 1816C	2006	8-41040
Engine Accessories	2007	8-41040
3 FUEL SYSTEM		
Engine Controls, Fuel Lines, Fuel Filter, Electric Fuel Pump	3001	8-41040
Carburetor - 1816C	3002	8-41040
4 ELECTRICAL		
Electrical System Troubleshooting	4002	8-41040
Wiring Diagrams	4003	8-41040
Gauges	4004	8-41040
Battery	4005	8-41040
Starter	4006	8-41040
NOTE: Also see the following sections:		
Starter - 1816 and 1816B	Sections 2001 and 2005	
Alternator - 1816, 1816B	Sections 2001 and 2005	
Alternator - 1816C	Sections 2006 and 4002	
Spark Ignition System - 1816, 1816B	Sections 2001 and 2005	
Spark Ignition System - 1816C	Sections 2006 and 4002	
6 POWER TRAIN		
Hydrostatic Troubleshooting, Testing, and Adjustment for Machines with Vickers Piston Pumps	6001	8-41040
Hydrostatic Troubleshooting, Testing, and Adjustment for Machines with Sundstrand Piston Pumps	6002	8-41040
Hydrostatic System Diagrams and Operation for Machines with Vickers Piston Pumps	6003	8-41040
Hydrostatic System Diagrams and Operation for Machines with Sundstrand Piston Pumps	6004	8-41040
Vickers Piston Pump	6005	8-41040
Sundstrand Piston Pump	6006	8-41040
Hydrostatic Motor	6007	8-41040

Reprinted

DIVISION/SECTION	SECTION NO.	FORM NO.
6 POWER TRAIN (CONT'D)		
Hydrostatic Controls for Machines with Vickers Piston Pumps . . .	6008	8-41040
Hydrostatic Controls for Machines with Sunstrand Piston Pumps .	6009	8-41040
Centrifugal Clutch - 1816	6010	8-41040
Electric Clutch - 1816	6011	8-41040
Belt Clutch	6012	8-41040
Drive Chains, Drive Axles, and Hubs	6013	8-41040
Wheels and Tires	6014	8-41040
7 BRAKES		
Parking Brake	7001	8-41040
8 HYDRAULICS		
Hydraulic Diagrams, Maintenance, and Troubleshooting	8002	8-41040
Cleaning the Hydraulic System	8003	8-41040
Equipment Pump	8005	8-41040
Equipment Control Valve	8007	8-41040
Auxiliary Control Valve	8031	8-41040
Cylinders	8090	8-41040
9 MOUNTED EQUIPMENT/CHASSIS		
Loader	9001	8-41040
Pallet Fork, Manure Fork, and Grapple	9002	8-41040
ROPS	9003	8-41040
Decals and Painting	9004	8-41040
Noise Control	9005	8-41040

Section 1001

SAFETY RULES SERVICE MANUAL INTRODUCTION AND TORQUE SPECIFICATIONS

Written In *Clear
And
Simple
English*

SAFETY RULES

This Symbol Shows Important Information About Safety In This Manual. When You See This Symbol, Carefully Read The Information That Follows and Understand The Possible Causes of Injury Or Death. 1-1-A

IMPORTANT: *To prevent injury on the job, follow the Warning, Caution, and Danger notes in this section and other sections throughout this manual. Follow the instructions carefully.*

The procedures recommended and shown in this manual are good, effective service methods. However, all possible procedures and service hazards may not be covered. Therefore, if you use a tool or procedure not recommended, you must make sure that the method you select is a safe method.

Put the warning tag shown below on the key for the key switch when you are servicing or repairing this machine. One warning tag is on every new machine. You can buy additional warning tags, part number 331-4614, from Service Parts Supply.

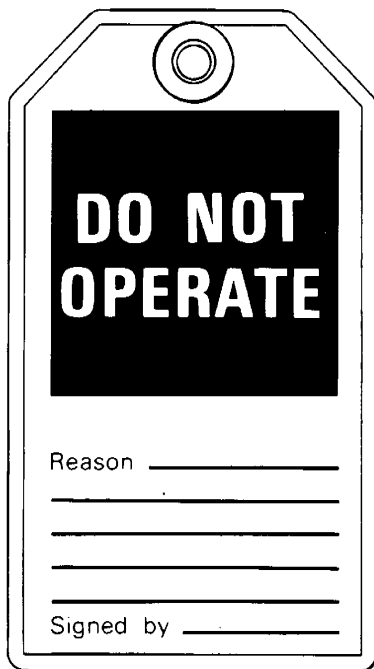

Figure 1

780449



DANGER: *Engine exhaust fumes can cause death. If it is necessary to start the engine in a closed place, remove the exhaust fumes from the area with an exhaust pipe extension. If you do not have an exhaust pipe extension, open the doors and get outside air into the area.*

48-56



WARNING: *Read operator's manual to familiarize yourself with control lever functions.*

46-27



WARNING: *Operate tractor and equipment controls from the seat position only. Any other method could result in serious injury.*

48-55



WARNING: *This is a one man machine, no riders allowed.*

35-8



WARNING: *If you wear clothing that is too loose or do not use the correct safety equipment for your job, you can be injured. Always wear clothing that will not catch on objects. Extra safety equipment that can be required includes hard hat, safety shoes, ear protection, eye or face protection, heavy gloves and reflector clothing.*

45-3-A



Figure 2



WARNING: *Operate controls from the operator's seat only.*

35-7



WARNING: *When working in the area of the fan belt with the engine running, avoid loose clothing if possible, and use extreme caution.*

35-4

**Thanks very much for your reading,
Want to get more information,
Please click here, Then get the complete
manual**

JustClickHere 

NOTE:

**If there is no response to click on the link above,
please download the PDF document first, and then
click on it.**

**Have any questions please write to me:
admin@servicemanualperfect.com**

WARNING: Whenever the bucket must be raised to aid in servicing, block the loader arms in place with lift cylinder support strut or a suitable safety stand. 23-7-B

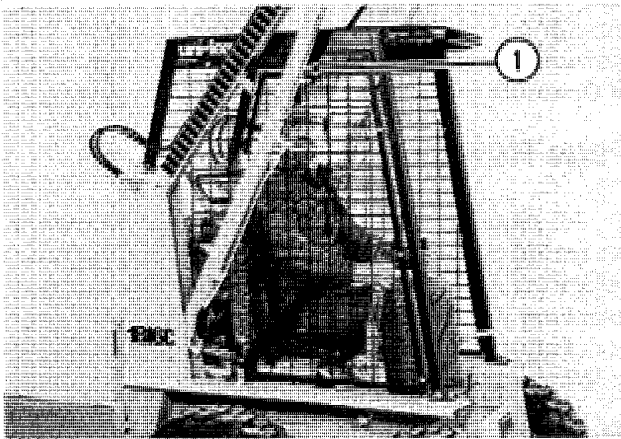

1. Lift Cylinder Support Strut

Figure 3

WARNING: When doing checks and tests on the equipment hydraulics, follow the procedures as they are written. DO NOT change the procedure. 47-44

WARNING: When putting the hydraulic cylinders on this machine through the necessary cycles to check operation or to remove air from a circuit, make sure all people are out of the way. 47-45

WARNING: Use insulated gloves or mittens when working with hot parts. 47-41A

CAUTION: Pin sized and smaller streams of hydraulic oil under pressure can penetrate the skin and result in serious infection. If hydraulic oil under pressure does penetrate the skin, seek medical treatment immediately. Maintain all hoses and tubes in good condition. Make sure all connections are tight. Make a replacement of any tube or hose that is damaged or thought to be damaged. DO NOT use your hand to check for leaks; use a piece of cardboard or wood. 40-6-A

CAUTION: When removing hardened pins such as a pivot pin, or a hardened shaft, use a soft head (brass or bronze) hammer or use a driver made from brass or bronze and a steel head hammer. 46-17

CAUTION: When using a hammer to remove and install pivot pins or separate parts, using compressed air or using a grinder, wear eye protection that completely encloses the eyes (approved goggles or other approved eye protectors). 46-13

CAUTION: When servicing or repairing the machine, keep the shop floor and operator's compartment and steps free of oil, water, grease, tools, etc. Use an oil absorbing material and/or shop cloths as required. Use safe practices at all times. 40-8

CAUTION: Use suitable floor (service) jacks or chain hoists to raise wheels or track off the floor. Always block machine in place with suitable safety stands. 40-7-A

CAUTION: Some components of this machine are very heavy. Use suitable lifting equipment or additional help as instructed in this service manual. 40-10

SERVICE MANUAL INTRODUCTION

This service manual has been prepared with the latest service information available. Troubleshooting, removal, disassembly, inspection and installation procedures, and complete specifications and tightening references can be found in most sections. Some sections have drawings but no written procedure because the job is so easily done. This service manual is one of the most important tools available to the service technician.

Right, Left, Front, and Rear

The terms right-hand and left-hand and front and rear as used in this manual indicate the right and left sides, and front and rear of the machine as seen from the operator's seat for correct operation of the machine or attachment.

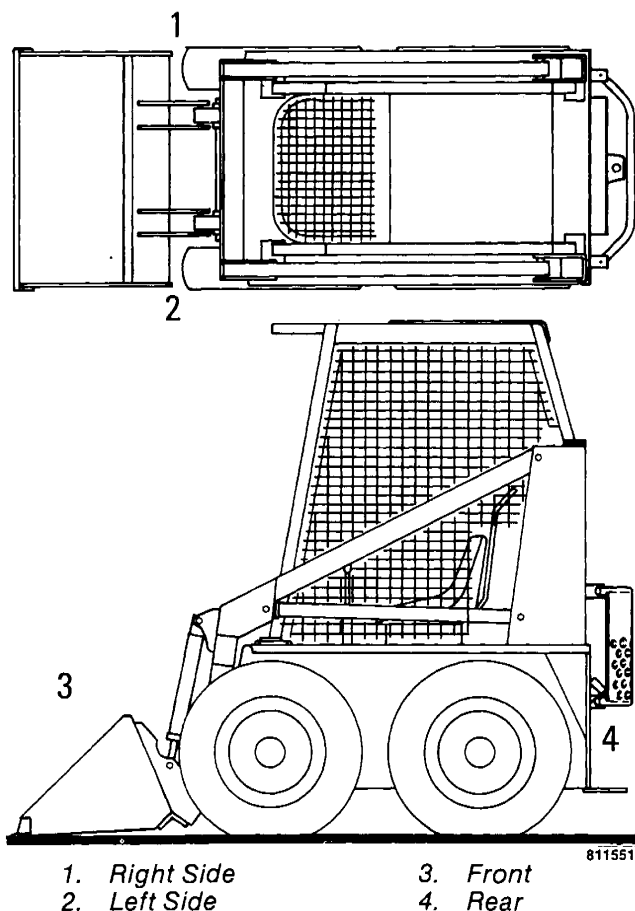

Figure 4

Text

If the service manual is for more than one machine or different models of components (planetary axles, gear boxes, control valves, etc.) the procedures have the steps necessary to service each model.

Table of Contents

A Table of Contents is in the front of this manual. The Table of Contents shows the main divisions and the sections that are in each division. The individual sections, where necessary, have a Table of Contents on the second page of that section.

Page Numbers

All page numbers are made of two numbers separated by a dash, such as 4002-9. The number before the dash is the section number. The number following the dash is the page number in that section. Page numbers will be found at the upper right or left of each page.

Illustrations

Illustrations are put as near as possible to the text and are to be used as part of the text.

Classification of Lubricants

The SAE number is the viscosity of engine oils; for example, SAE 30, a single viscosity oil. SAE 10W30 is a variable viscosity oil.

The API classification (SD, CD, etc.) is the oil performance in terms of engine usage. Only oils specified in Section 1002 can be used. These oils have the needed chemical additives to give maximum engine protection. Both the SAE grade and API classification must be found on the container.

Special Tools

Special tools are needed to remove and install, disassemble and assemble, check and adjust some component parts of this machine. Some special tools can be easily made locally and the necessary information to make the tool is in this service manual. Other special tools are more difficult to make locally and are available from Service Tools in the U.S. and from Jobborn Manufacturing in Canada. Use these tools according to the instructions in this service manual for your personal safety and to do the job correctly.

Order special tools from either of the following companies:

Service Tools
P.O. Box 314
Owatonna, Minnesota 55060

Jobborn Manufacturing Co.
97 Frid Street
Hamilton, Ontario L8P 4M3
Canada

Product Identification Number (PIN) and Serial Numbers

NOTE 1: 1816 and 1816B - Engine serial number is on carburetor side of blower housing. ROPS serial number is above operators head at front of the ROPS.

NOTE 2: All models - Bucket serial number is on the back of the spillguard.

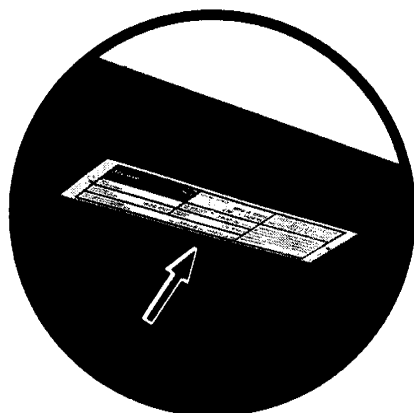

SN OF ROPS
CANOPY

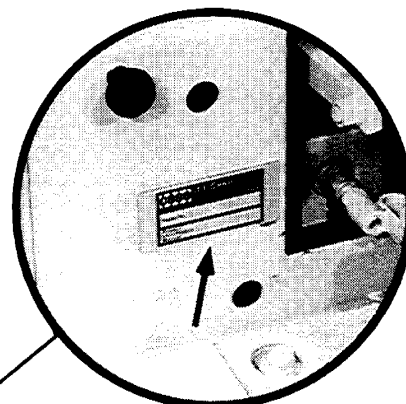

PRODUCT
IDENTIFICATION NUMBER

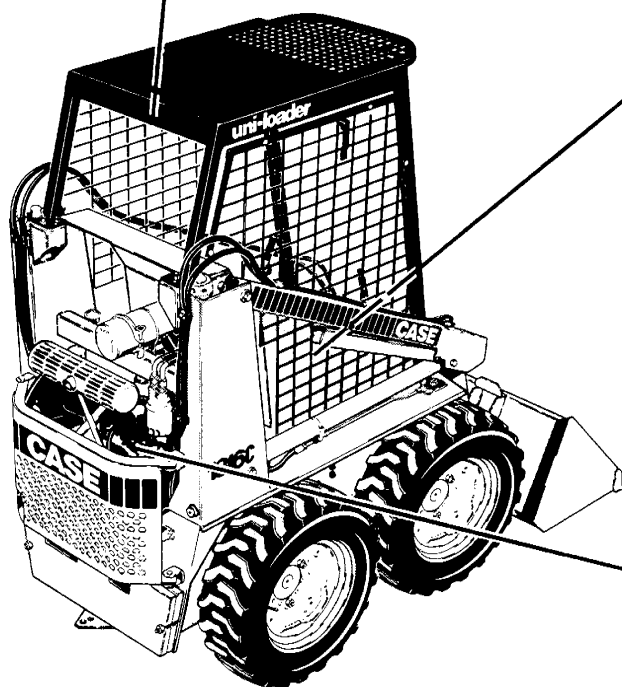

SN OF ENGINE







810225

Figure 5 - 1816C Illustrated





TORQUE SPECIFICATIONS

(Use the following torques when special torques are not given.)

Grade 5 Bolts, Nuts and Studs (Dry Threads)

Thread size	Pound-Feet	Newton metres	Kilogram metres		Thread size	Pound-Feet	Newton metres	Kilogram metres
1/4-20 NC	5-10	7-14	0.7-1.4		3/4-10 NC	235-285	319-386	32.5-39.4
1/4-28 NF	10-15	14-20	1.4-2.1		3/4-16 NF	270-330	366-447	37.3-45.6
5/16-18 NC	15-20	20-27	2.1-2.8		7/8-9 NC	360-440	488-597	49.8-60.8
5/16-24 NF	15-20	20-27	2.1-2.8		7/8-14 NF	395-490	536-664	54.6-67.7
3/8-16 NC	25-35	34-47	3.5-4.8		1-8 NC	520-640	705-868	71.9-88.5
3/8-24 NF	30-40	41-54	4.1-5.5		1-12 NF	575-705	780-955	79.5-97.5
7/16-14 NC	45-55	61-75	6.2-7.6		1-1/8-7 NC	720-820	966-1112	99.5-113
7/16-20 NF	50-60	68-81	6.9-8.3		1-1/8-12 NF	790-970	1071-1315	109-134
1/2-13 NC	65-85	88-115	9.0-11.8		1-1/4-7 NC	1010-1240	1370-1681	140-171
1/2-20 NF	80-100	108-136	11.1-13.8		1-1/4-12 NF	1115-1365	1512-1851	154-189
9/16-12 NC	100-120	136-163	13.8-16.6		1-3/8-6 NC	1315-1610	1783-2183	182-223
9/16-18 NF	110-130	149-176	15.2-18.0		1-3/8-12 NF	1510-1850	2048-2509	209-256
5/8-11 NC	135-165	183-224	18.7-22.8		1-1/2-6 NC	1745-2135	2366-2895	241-295
5/8-18 NF	160-200	216-271	22.1-27.7		1-1/2-12 NF	1880-2420	2549-3282	260-335

Grade 8 Bolts, Nuts and Studs (Dry Threads)

Thread size	Pound-Feet	Newton metres	Kilogram metres		Thread size	Pound-Feet	Newton metres	Kilogram metres
1/4-20 NC	10-15	14-20	1.4-2.1		3/4-10 NC	340-420	461-570	47.0-58.1
1/4-28 NF	15-20	20-27	2.1-2.8		3/4-16 NF	380-460	515-623	52.5-63.6
5/16-18 NC	20-30	27-41	2.8-4.1		7/8-9 NC	540-660	732-895	74.7-91.2
5/16-24 NF	25-30	34-41	3.5-4.1		7/8-14 NF	595-725	807-983	82.3-100
3/8-16 NC	40-50	54-68	5.5-6.9		1-8 NC	810-990	1098-1342	112-137
3/8-24 NF	45-55	61-75	6.2-7.6		1-12 NF	900-1100	1220-1491	124-152
7/16-14 NC	60-80	81-108	8.3-11.1		1-1/8-7 NC	1150-1400	1559-1898	159-194
7/16-20 NF	70-90	95-122	9.7-12.4		1-1/8-12 NF	1295-1585	1756-2149	179-219
1/2-13 NC	100-120	136-163	13.8-16.6		1-1/4-7 NC	1640-2000	2224-2712	227-277
1/2-20 NF	110-130	149-176	15.2-18.0		1-1/4-12 NF	1800-2200	2441-2983	249-304
9/16-12 NC	135-165	183-224	18.7-22.8		1-3/8-6 NC	2140-2620	2902-3553	296-362
9/16-18 NF	155-190	210-258	21.4-26.3		1-3/8-12 NF	2450-3000	3322-4068	339-415
5/8-11 NC	200-240	271-325	27.7-33.2		1-1/2-6 NC	2845-3475	3858-4712	393-480
5/8-18 NF	215-265	292-359	29.7-36.6		1-1/2-12 NF	3200-3900	4339-5288	442-539

TORQUE SPECIFICATIONS FOR STEEL HYDRAULIC FITTINGS

Dash Size	Tube O.D. Hose I.D.	Thread Size	37 Degree Flare			Straight Thread With O-ring		
			Pound-Feet	Newton metres	Kilogram metres	Pound-Feet	Newton metres	Kilogram metres
4	1/4 in (6.4 mm)	7/16-20	6-12	8-16	0.8-1.6	12-19	16-26	1.6-2.6
5	5/16 in (7.9 mm)	1/2-20	8-16	11-22	1.1-2.2	16-25	22-34	2.2-3.4
6	3/8 in (9.5 mm)	9/16-18	10-25	14-34	1.4-3.4	25-40	34-54	3.4-5.5
8	1/2 in (12.7 mm)	3/4-16	15-42	20-57	2.1-5.8	42-67	57-91	5.8-9.3
10	5/8 in (15.9 mm)	7/8-14	25-58	34-79	3.4-8.0	58-92	79-125	8.0-12.7
12	3/4 in (19.0 mm)	1-1/16-12	40-80	54-108	5.5-11.0	80-128	108-174	11.0-17.7
14	7/8 in (22.2 mm)	1-3/16-12	60-100	81-136	8.3-13.8	100-160	136-217	13.8-22.1
16	1.0 in (25.4 mm)	1-5/16-12	75-117	102-159	10.4-16.2	117-187	159-254	16.2-25.9
20	1-1/4 in (31.8 mm)	1-5/8-12	125-165	169-224	17.3-22.8	165-264	224-358	22.8-36.4
24	1-1/2 in (38.1 mm)	1-7/8-12	210-250	285-339	29.0-34.6	250-400	339-542	34.6-55.3

Split Flange Mounting Bolts (Grade 5, Dry Threads)

Thread Size	Pound-Feet	Newton metres	Kilogram metres
5/16-18 NC	15-20	20-27	2.1-2.8
3/8-16 NC	20-25	27-34	2.8-3.5
7/16-14 NC	34-45	46-61	4.7-6.2
1/2-13 NC	55-65	75-88	7.6-9.0
5/8-11 NC	140-150	190-203	19.4-20.7

NOTES

Section 1002

MAINTENANCE AND LUBRICATION

Written In *Clear
And
Simple
English*

FLUIDS AND LUBRICANTS

COMPONENT	CAPACITY		SPECIFICATIONS
	U.S.	Metric	
Fuel tank	8.5 gallons	32.2 litres	See the Operators Manual
Engine crankcase			Engine oil with API service classification of SE or SE/CC.
With filter change	2.3 quarts	2.2 litres	Above 32° F (0°) SAE 30 or SAE 40
Without filter change	1.75 quarts	1.6 litres	Below 32° F (0°) SAE 10W-30 or SAE 10W-40
			Below 0° F (-18°) SAE 5W-30 or SAE 5W-20
Hydraulic reservoir			SAE 10W-40 engine oil with API classification of SD or SE
With filter change	15 quarts	14.2 litres	
Without filter change	14 quarts	13.2 litres	
Grease fittings	As required		Case molydisulfide multipurpose grease
Battery	As required		Clean water or distilled water
Hydrostatic motor shaft splines	As required		Molykote, Type G grease, Case part number D60210

MAINTENANCE CHART

This chart shows maximum service intervals for the correct maintenance of the machine. Some working conditions will make it necessary to shorten the service intervals.

INTERVAL	SERVICE	INSTRUCTIONS
After the first two hours of operation, new machine only	<p>Check the drive belt tensions.</p> <p>Tighten wheel nuts every two hours until the wheel nuts stay tight.</p>	<p>1816 - See Section 2003. 1816B and 1816C - See Section 6012.</p> <p>See Section 6014.</p>
After the first 20 hours of operation, new machine only	Do the After Delivery Check.	See the Operators Manual.
After the first 50 hours of operation, new machine only	Check the engine valve clearance.	1816 and 1816B - See the Tecumseh manual. 1816C - See Section 2006.
Every five hours of operation or two times each day	Check the engine oil level.	
Every 10 hours of operation or each day, whichever occurs first	<p>Clean the dust cup in the air cleaner.</p> <p>Make sure that the hydraulic oil cooler is clean. Check for damage.</p> <p>Check the hydraulic filter condition indicator.</p> <p>Lubricate the pivot points on the loader and the grapple.</p> <p>Clean or replace all safety and instruction decals that cannot be read.</p> <p>Check the tires for deep cuts and other damage.</p> <p>Visually check the machine for loose, broken, or missing parts. Check for oil leaks.</p>	<p>See Section 2007.</p> <p>See Section 8002.</p> <p>See Section 9004.</p>
Every 25 hours or operation or two times each week	<p>Change the engine oil.</p> <p>Tighten all hose clamps.</p>	

(Continued on next page)

INTERVAL	SERVICE	INSTRUCTIONS
Every 50 hours of operation or each week, whichever occurs first	Check the electrolyte level in the battery. Check the pressure in the tires. Lubricate the control lever linkage. Change the engine oil filter. Check the hydraulic oil level. Clean the engine cooling fins. Check the drive belt tensions.	See Section 4005. See Section 6014. See Section 8002. 1816 - See Section 2003. 1816B and 1816C - See Section 6012.
After every 100 hours of operation	Replace the spark plugs. Check the condition of the breaker contact points. Clean the spark arrester muffler (if equipped).	1816 and 1816B - See the Tecumseh manual. 1816C - See Section 2006. 1816 and 1816B - See the Tecumseh manual. 1816C - See Section 2006. See Section 2007.
After every 200 hours of operation	Check the engine valve clearance. Check the tension of the drive chains. Clean the engine breather mechanism. Check the engine compression.	1816 and 1816B - See the Tecumseh manual. 1816C - See Section 2006. See Section 6013. 1816 and 1816B - See the Tecumseh manual. 1816C - See Section 2006. 1816 and 1816B - See the Tecumseh manual. 1816C - See Section 2002.
Every 500 hours of operation of two times each year	Inspect the ROPS	See Section 9003.
Every 1000 hours of operation or one time each year	Lubricate the shaft splines on the hydrostatic motors. Replace the fuel filter and drain the fuel tank. Change the hydraulic oil. Clean the hydraulic reservoir breathers. Replace the air cleaner element.	See Section 6007. See Section 3001. See Section 8002. See Section 8002. See Section 2007.

INTERVAL	SERVICE	INSTRUCTIONS
As required	<p>Replace the air cleaner element.</p> <p>Replace the fuel filter.</p> <p>Replace the hydraulic oil filter.</p> <p>Check the operation of the steering controls and adjust as required.</p> <p>Clean the drive chains with a stiff brush and lubricate with SAE 30 engine oil.</p> <p>When you operate the machine in sand or severe dust conditions, check and clean the chain compartments each day.</p> <p>Clean the machine.</p>	<p>See Section 2007.</p> <p>See Section 3001.</p> <p>See Section 8002.</p> <p>See Section 6008 or Section 6009.</p> <p>See Section 6013.</p>

NOTES

Section 1003

ENGINE SPECIFICATIONS - 1816C

Written In *Clear
And
Simple
English*

TABLE OF CONTENTS

Specifications	1003-3
General	1003-3
Cylinder Sleeve	1003-3
Piston	1003-4
Piston Rings	1003-4
Piston Pin	1003-4
Connecting Rod	1003-4
Crankshaft	1003-5
Main Bearing	1003-5
Camshaft	1003-5
Camshaft Bearing	1003-5
Lubrication System	1003-6
Valve Tappets	1003-6
Exhaust Valve	1003-6
Intake Valve	1003-7
Valve Springs	1003-7
Ignition	1003-7
Fuel System	1003-7
Special Torques	1003-8

SPECIFICATIONS

General

Engine Manufacturer	Onan
Type	2 cylinder, 4 cycle, L-head
Bore	3.249 - 3.250 inches (82.53 - 82.55 mm)
Stroke	2.62 inches (66.5 mm)
Compression Ratio	6.6:1
Piston Displacement	43.3 cubic inches (709.6 cm ³)
Engine Speeds	
Full Throttle - No Load	3700 - 3800 rpm (r/min)
Full Throttle - Full Load	3600 rpm (r/min)
Low Idle	950 - 1050 rpm (r/min)
Valve Tappet Clearance (Cold)	
Intake008 inch (0.20 mm)
Exhaust013 inch (0.33 mm)
Valve Rotators	positive type
Starter Gear to Ring Gear Backlash010 - .030 inch (0.25 - 0.76 mm)

Cylinder Sleeve

Type	cast into cylinder block
Material	pearlitic iron
ID of Cylinder Sleeve (Standard Size)	3.249 to 3.250 inches (82.53 to 82.55 mm)
Maximum Permitted Out of Round002 inch (0.05 mm)
Maximum Permitted Taper005 inch (0.13 mm)
Piston Clearance (Measured .10 Inch (2.5 mm) Below Oil Control Ring, 90 Degrees From Piston Pin)004 to .006 inch (0.10 to 0.15 mm)

Piston

Type	die cast, wave ground
Material	eutectic aluminum alloy
Diameter	3.243 - 3.244 inches (82.37 - 82.40 mm)
Ring Groove Width	
Number One Compression080 - .081 inch (2.03 - 2.06 mm)
Number Two Compression080 - .081 inch (2.03 - 2.06 mm)
Number Three Oil Control188 - .189 inch (4.78 - 4.80 mm)

Piston Rings

Number Per Piston	three
Number of Compression Rings	two
Number of Oil Control Rings	one
Number One Compression	
Type	molybdenum filled
End Gap010 - .020 inch (0.25 - 0.51 mm)
Side Clearance002 - .008 inch (0.051 - 0.203 mm)
Number Two Compression	
End Gap010 - .020 inch (0.25 - 0.51 mm)
Number Three Oil Control	
Type	two piece
End Gap010 - .020 inch (0.25 - 0.51 mm)

Piston Pin

Type	full floating
Diameter687 - .688 inch (17.45 - 17.48 mm)
Fit in Piston0002 - .0004 inch (0.005 - 0.010 mm)
Fit in Connecting Rod0002 - .0007 inch (0.005 - 0.018 mm)

Connecting Rod

Material	aluminum alloy
Crankshaft to Connecting Rod Clearance002 - .003 inch (0.05 - 0.08 mm)
Side Clearance002 - .016 inch (0.05 - 0.41 mm)

Crankshaft

Type	balanced
Material	ductile iron, induction hardened main bearing journals
Main Bearing Journal (Standard Size)	1.999 - 2.000 inches (50.78 - 50.80 mm)
Connecting Rod Journal (Standard Size)	1.625 - 1.626 inch (41.28 - 41.30 mm)
Crankshaft to Main Bearing Clearance002 - .004 inch (0.05 - 0.10 mm)
Crankshaft End Play006 - .012 inch (0.15 - 0.30 mm)
Crankshaft Gear to Camshaft Gear Backlash002 - .003 inch (0.05 - 0.08 mm)

Main Bearing

Type	replaceable precision with thrust washer
Material	steel back aluminum
Length	one inch (25.4 mm)
Diameter (Standard Size)	2.001 - 2.004 inches (50.83 - 50.90 mm)

Camshaft

Material	cast iron alloy
Camshaft Lift300 inch (7.62 mm)
Camshaft End Play (Minimum)003 inch (0.08 mm)
Camshaft Journal Diameter	1.374 inch (34.90 mm)
Camshaft to Camshaft Bearing Clearance001 - .003 inch (0.04 - 0.08 mm)
Length of Center Pin Extension From Camshaft Gear	25/32 inch (19.8 mm)
Governor Cup Travel on Center Pin	7/32 inch (5.6 mm)

Camshaft Bearing

Number	two
Type	replaceable precision
Material	lead babbitt
Diameter	1.376 - 1.377 inch (34.95 - 34.98 mm)