



# Service Manual

## Three-Point Rotary Cutter

---

(3RC60) S/N A7RR00101 & Above  
(3RC70) S/N A7RS00101 & Above

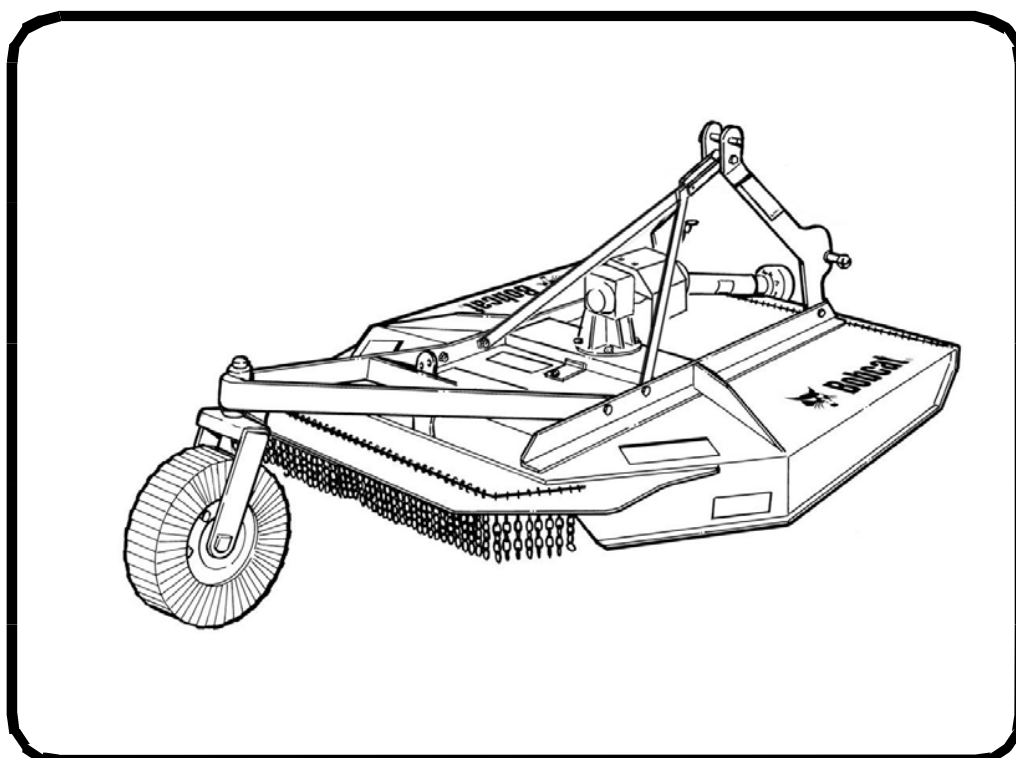



# MAINTENANCE SAFETY



## WARNING







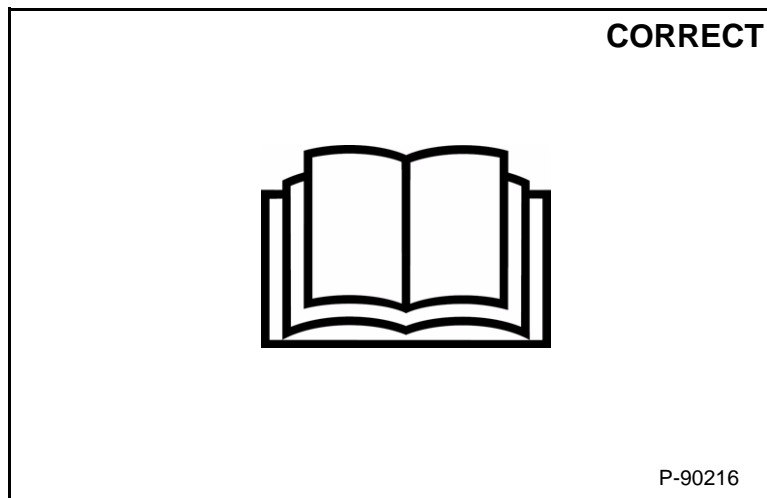

Instructions are necessary before operating or servicing machine. Read and understand the Operation & Maintenance Manual, Operator's Handbook and signs (decals) on machine. Follow warnings and instructions in the manuals when making repairs, adjustments or servicing. Check for correct function after adjustments, repairs or service. Untrained operators and failure to follow instructions can cause injury or death.

W-2003-0807



**Safety Alert Symbol:** This symbol with a warning statement, means: "Warning, be alert! Your safety is involved!" Carefully read the message that follows.



-  Never service attachments / implements without instructions. See Operation & Maintenance Manual and Attachment / Implement Service Manual.
-  Cleaning and maintenance are required daily.
-  Never service or adjust attachment / implement with the engine running unless instructed to do so in manual.
-  Always lower the attachment / implement to the ground before lubricating or servicing.
-  Avoid contact with leaking hydraulic fluid or diesel fuel under pressure. It can penetrate skin or eyes.
-  Stop, cool and clean engine of flammable materials before checking fluids.
-  Keep body, loose objects and clothing away from moving parts, electrical contacts, hot parts and exhaust.
-  Safety glasses are needed for eye protection from electrical arcs, battery acid, compressed springs, fluids under pressure and flying debris or when tools are used. Use eye protection approved for type of welding.



**Bobcat®**

## ALPHABETICAL INDEX

(3RC60, 3RC70) SPECIFICATIONS.....	SPEC-10-1
ATTACHMENT STORAGE AND RETURN TO SERVICE .....	10-60-1
CASTER WHEEL .....	20-20-1
CUTTING BLADES .....	20-10-1
DELIVERY REPORT.....	III
GEARBOX.....	20-40-1
IDENTIFICATION AND MACHINE SIGNS (DECALS) .....	IV
LUBRICATING THE ATTACHMENT.....	10-30-1
MANUAL STORAGE.....	III
PTO DRIVELINE.....	20-30-1
REGULAR MAINTENANCE ITEMS .....	10-70-1
REMOVAL AND INSTALLATION OF CHAIN GUARDS .....	10-40-1
REMOVAL AND INSTALLATION OF SHEAR BOLT (GRADE 2) ..	10-50-1
SERIAL NUMBER LOCATION .....	III
SERVICE SCHEDULE .....	10-20-1
TROUBLESHOOTING .....	10-10-1



**Bobcat®**

# CONTENTS

**SAFETY &  
MAINTENANCE**

**MAIN  
FRAME**

**SPECIFICATIONS  
AND  
SCHEMATICS**

SERIAL NUMBER LOCATION ..... III  
MANUAL STORAGE ..... III  
DELIVERY REPORT ..... III  
IDENTIFICATION AND MACHINE SIGNS (DECALS) ..... IV  
SAFETY & MAINTENANCE ..... 10-01  
MAIN FRAME ..... 20-01  
SPECIFICATIONS AND SCHEMATICS ..... SPEC-01

## REFERENCE INFORMATION

Write the correct information for YOUR three-point rotary cutter in the spaces below. Always use these numbers when referring to your three-point rotary cutter.

Three-Point Rotary Cutter  
Serial Number

---

---

---

---

NOTES:

---

---

---

---

YOUR BOBCAT® DEALER:

ADDRESS:

PHONE:

Bobcat Company  
P.O. Box 128  
Gwinner, ND 58040-0128

Bobcat Company Europe  
Drève Richelle 167  
B-1410 WATERLOO  
Belgium



**Bobcat®**



## SERIAL NUMBER LOCATION

Figure 1

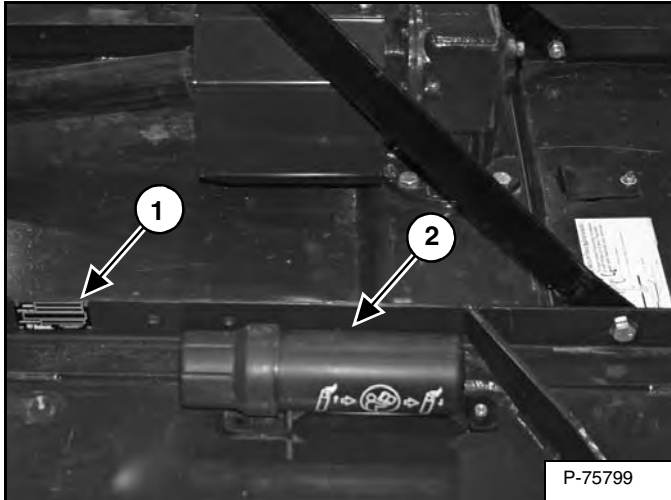

Always use the serial number (Item 1) **[Figure 1]** of the three-point rotary cutter when requesting service information or when ordering parts. Early or later models (identification made by serial number) may use different parts, or it may be necessary to use a different procedure in doing a specific service operation.

## MANUAL STORAGE

The manual storage container (Item 2) **[Figure 1]** is located just to the rear of the serial number plate.

## DELIVERY REPORT

Figure 2

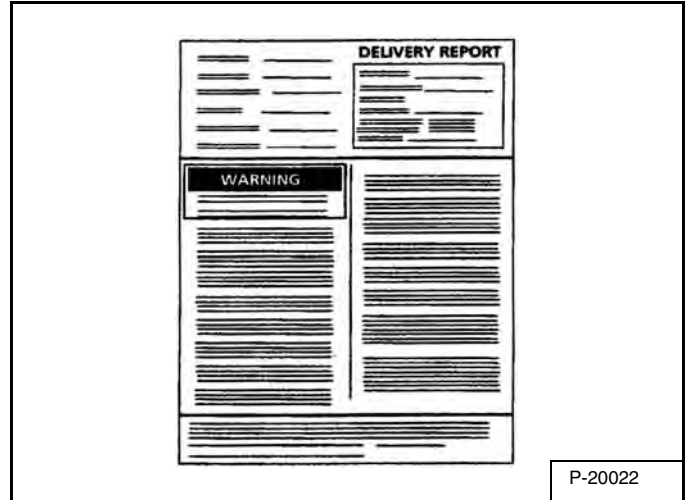

The delivery report must be filled out by the dealer and signed by the owner or operator when the three-point rotary cutter is delivered. An explanation of the form must be given to the owner. Make sure it is filled out completely **[Figure 2]**.

**IDENTIFICATION AND MACHINE SIGNS (DECALS)**

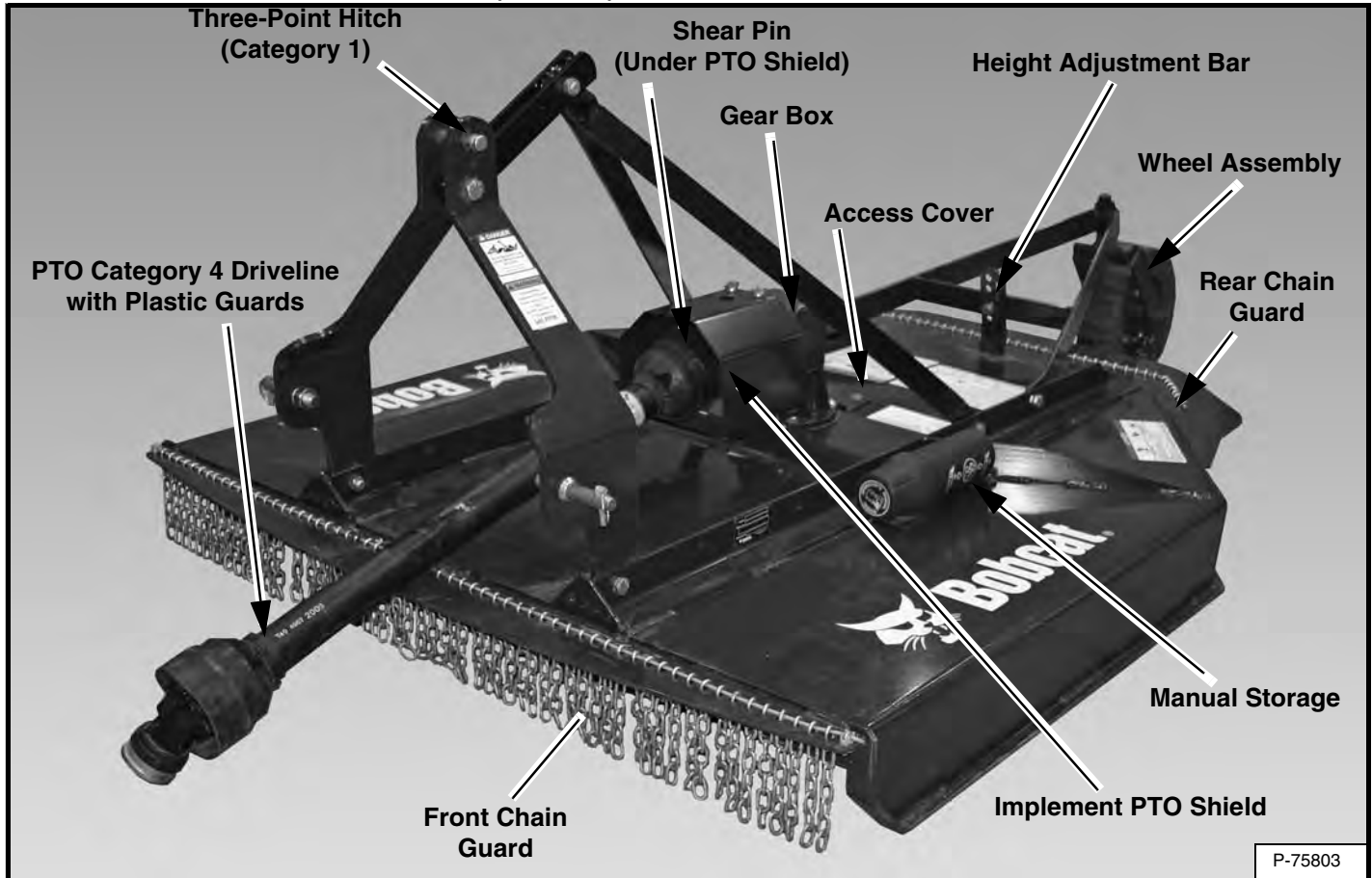

P-75803

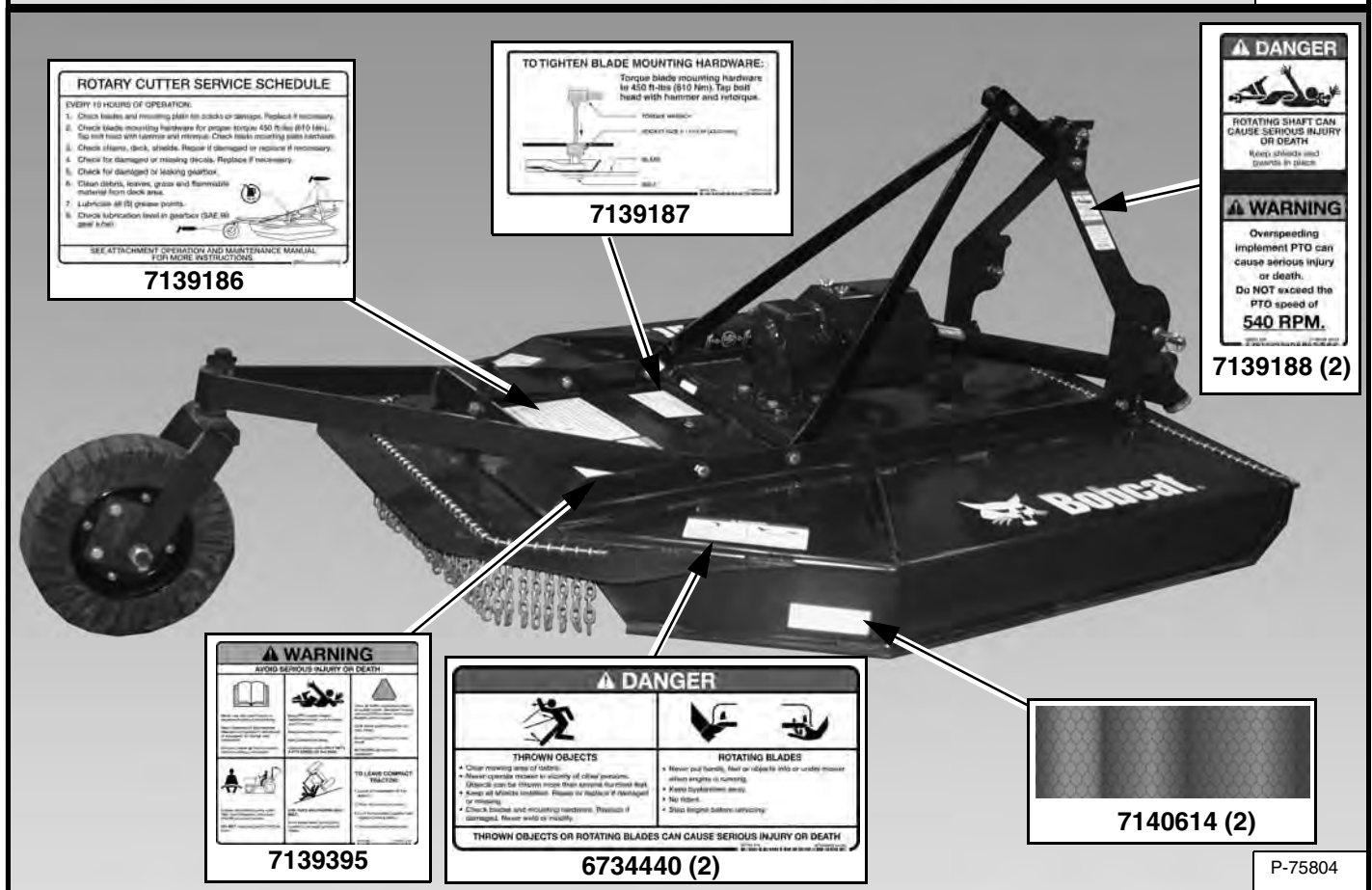

P-75804

**SAFETY & MAINTENANCE**

ATTACHMENT STORAGE AND RETURN TO SERVICE ..... 10-60-1  
    Return to Service ..... 10-60-1  
    Storage ..... 10-60-1

LUBRICATING THE ATTACHMENT ..... 10-30-1  
    Lubrication Locations ..... 10-30-1

REGULAR MAINTENANCE ITEMS ..... 10-70-1  
    Cleaning The Three-Point Rotary Cutter ..... 10-70-1  
    Gearbox Fluid ..... 10-70-1

REMOVAL AND INSTALLATION OF CHAIN GUARDS ..... 10-40-1  
    Procedure ..... 10-40-1

REMOVAL AND INSTALLATION OF SHEAR BOLT (GRADE 2) ..... 10-50-1  
    Procedure ..... 10-50-1

SERVICE SCHEDULE ..... 10-20-1  
    Chart ..... 10-20-1

TROUBLESHOOTING ..... 10-10-1  
    Chart ..... 10-10-1



**Bobcat®**

## TROUBLESHOOTING

### Chart

<b>PROBLEM</b>	<b>CAUSE</b>	<b>CORRECTION</b>
Poor Cutting.	Travel speed too fast.	Reduce travel speed.
	Debris on blade mounting plate.	Clean mounting plate.
	Blades worn or damaged.	Replace blades.
Blades will not rotate.	Debris between blades and mounting plate.	Remove debris.
	Broken shear bolt.	Replace shear bolt.



**Bobcat®**

# ROTARY CUTTER SERVICE SCHEDULE

## EVERY 10 HOURS OF OPERATION:

1. Check blades and mounting plate for cracks or damage. Replace if necessary.
2. Check blade mounting hardware for proper torque 450 ft-lbs (610 Nm). Tap bolt head with hammer and retorque. Check blade mounting plate hardware.
3. Check chains, deck, shields. Repair if damaged or replace if necessary.
4. Check for damaged or missing decals. Replace if necessary.
5. Check for damaged or leaking gearbox.
6. Clean debris, leaves, grass and flammable material from deck area.
7. Lubricate all (5) grease points.
8. Check lubrication level in gearbox (SAE 90 gear lube).

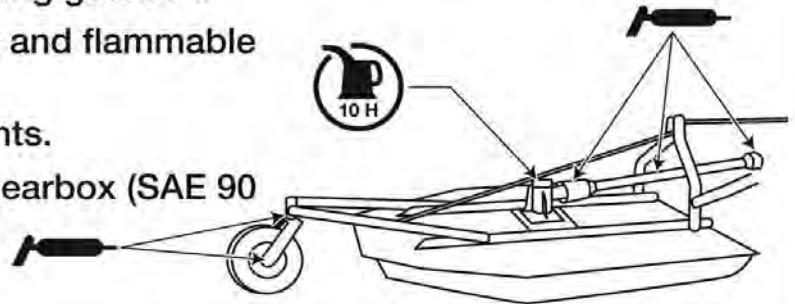

SEE ATTACHMENT OPERATION AND MAINTENANCE MANUAL FOR MORE INSTRUCTIONS.

68916 SW 7139186 enUS  
© 2014 John Deere LLC. All rights reserved. John Deere, the John Deere logo and "L" logo are trademarks of John Deere LLC.

7139186



**Bobcat®**



## LUBRICATING THE ATTACHMENT

### Lubrication Locations

Always use a good quality lithium base multi-purpose grease when lubricating the attachment. Apply lubricant until extra grease shows.

# IMPORTANT

Fluid such as engine oil, hydraulic fluid, coolants, grease, etc. must be disposed of in an environmentally safe manner. Some regulations require that certain spills and leaks on the ground must be cleaned in a specific manner. See local, state and federal regulations for the correct disposal.

I-2067-0499

Figure 10-30-1

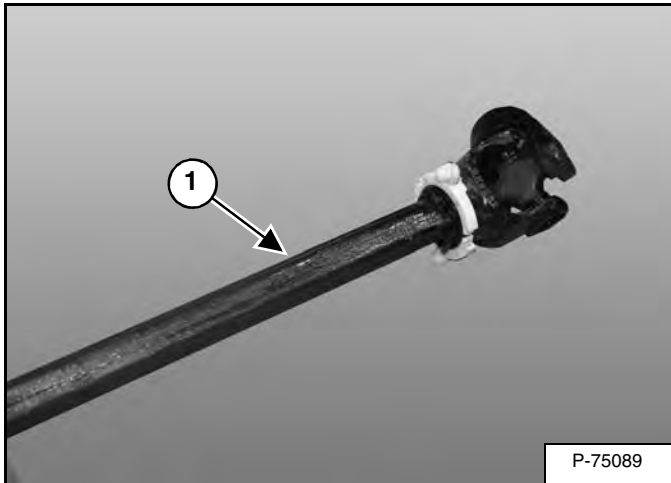

Lubricate the following every 10 hours of operation.

Apply grease to the PTO driveline (Item 1) [Figure 10-30-1].

Figure 10-30-2

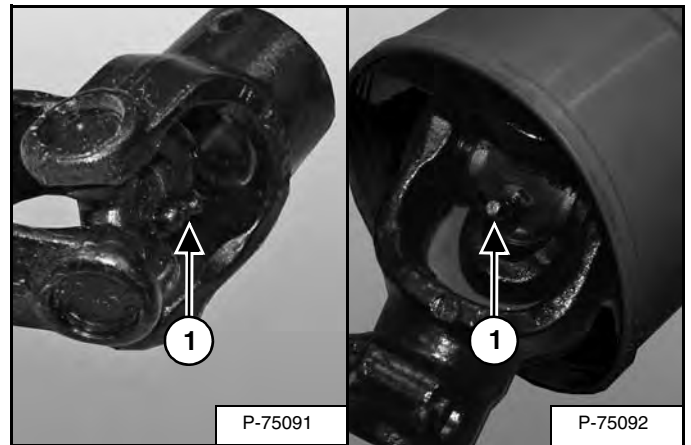

Lubricate the u-joints (Item 1) [Figure 10-30-2] on both ends of the PTO driveline.

Figure 10-30-3

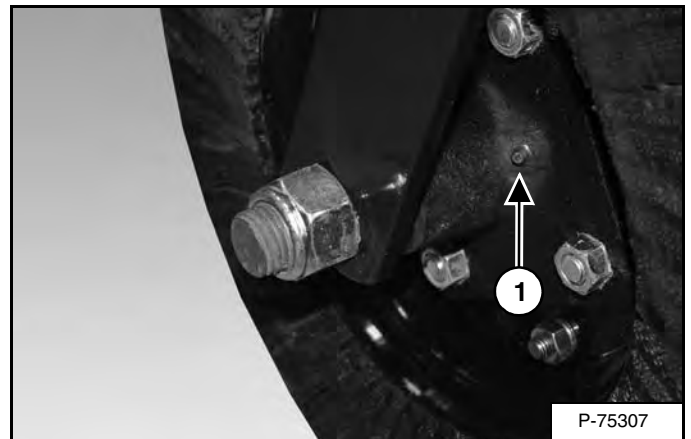

Lubricate the fitting (Item 1) [Figure 10-30-3] on the wheel hub.

Figure 10-30-4

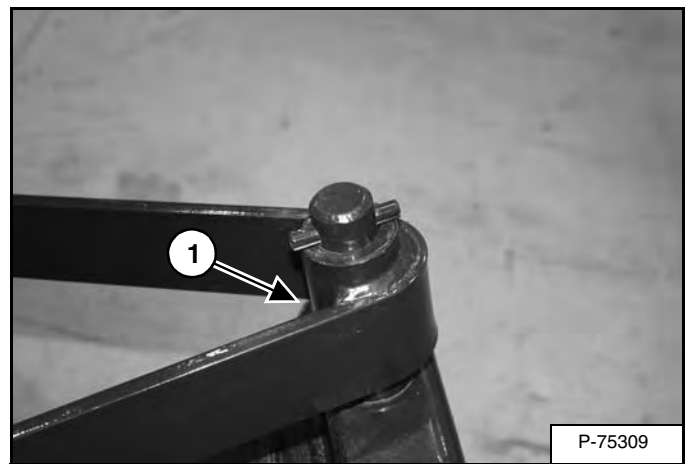

Lubricate the fitting (Item 1) [Figure 10-30-4] on the pivot shaft.



**Bobcat®**

**Dear**

**Thanks very much for your visiting and  
patience.**

**Want to get more information,**

**Please click here, Go back to the page.**

**After your payment, you will have instant access to  
your download.**

**The Download Link will also be sent to your e-mail.**

**You will get the complete manual**

**Have any questions**

**please write to me**

**[admin@servicemanualperfect.com](mailto:admin@servicemanualperfect.com)**