

2

0

0

0



# Service Manual

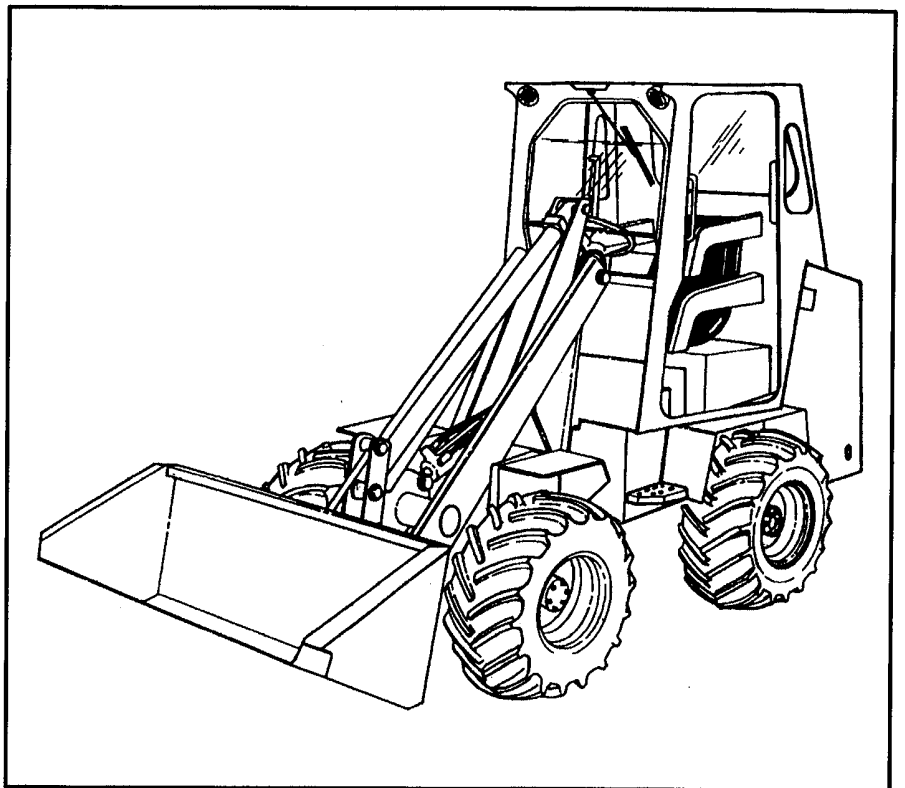

**MELROE**  
**INGERSOLL-RAND**

6566180(4-85)

Printed in U.S.A.



© Melroe Company 1985



# MAINTENANCE SAFETY



## WARNING

Instructions are necessary before operating or servicing machine. Read and understand the Operation & Maintenance Manual, Operator's Handbook and signs (decals) on machine. Follow warnings and instructions in the manuals when making repairs, adjustments or servicing. Check for correct function after adjustments, repairs or service. Untrained operators and failure to follow instructions can cause injury or death.

W-2003-0903



**Safety Alert Symbol:** This symbol with a warning statement, means: "Warning, be alert! Your safety is involved!" Carefully read the message that follows.

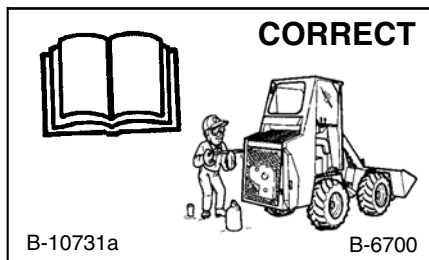

⚠ Never service the Bobcat Loader without instructions. See Service Manual.

⚠ Check engine and hydraulic fluids daily.

⚠ Use recommended fluids.

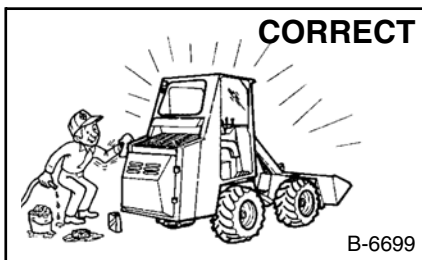

⚠ Cleaning and maintenance are required daily.

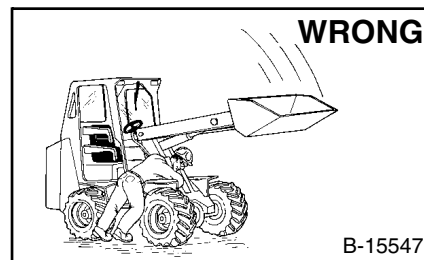

⚠ Disconnecting or loosening any hydraulic tubeline, hose, fitting, component or a part failure can cause lift arms to drop. Do not go under lift arms when raised unless supported by an approved lift arm support device. Replace it if damaged.

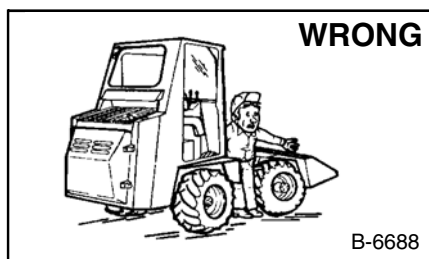

⚠ Always connect steering frame lock before working on the loader.

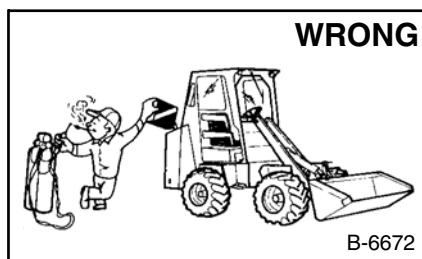

⚠ Do not fill the fuel tank with engine running, while smoking or when near an open flame.



⚠ Never work on loader with lift arms up unless lift arms are held by an approved lift arm support device.

⚠ Never modify equipment or add attachments not approved by Bobcat Company.

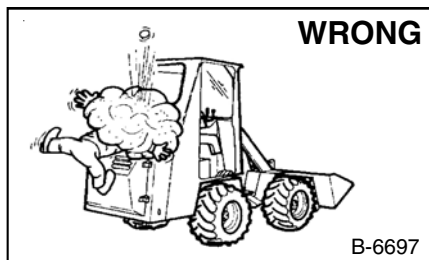

⚠ Stop, cool and clean engine of flammable materials before checking fluids.

⚠ Never service or adjust loader with the engine running unless instructed to do so in the manual.

⚠ Avoid contact with leaking hydraulic fluid or diesel fuel under pressure. It can penetrate the skin or eyes.

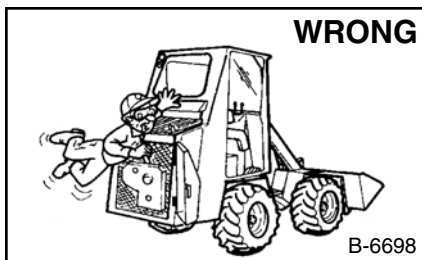

⚠ Keep body, jewelry and clothing away from moving parts, electrical contact, hot parts and exhaust.

⚠ Wear eye protection to guard from battery acid, compressed springs, fluids under pressure and flying debris when engines are running or tools are used. Use eye protection approved for type of welding.

⚠ Keep rear door closed except for service. Close and latch door before operating the loader.

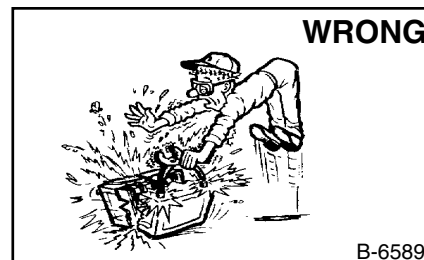

⚠ Lead-acid batteries produce flammable and explosive gases.

⚠ Keep arcs, sparks, flames and lighted tobacco away from batteries.

⚠ Batteries contain acid which burns eyes or skin on contact. Wear protective clothing. If acid contacts body, flush well with water. For eye contact flush well and get immediate medical attention.

Maintenance procedures which are given in the Operation & Maintenance Manual can be performed by the owner/operator without any specific technical training. Maintenance procedures which are **not** in the Operation & Maintenance Manual must be performed **ONLY BY QUALIFIED BOBCAT SERVICE PERSONNEL**. Always use genuine Bobcat replacement parts. The Service Safety Training Course is available from your Bobcat dealer.

MSW04-0805



**Bobcat®**

# FOREWORD

This manual gives instruction for correct servicing and adjustment of the Bobcat loader and overhaul instructions of the drive system, loader hydraulic/hydrostatic system and general main frame parts.

Refer to the Operator's Manual for operating instructions (Starting Procedure, Daily Checks, Bucket Operation, etc.).

A general inspection of the following items must be made whenever the loader has had service or repair:

1. Check hydraulic fluid level, engine oil level and fuel supply.
2. Inspect for any sign of fuel, oil or hydraulic fluid leaks.
3. Lubricate the loader.
4. Check battery condition and cables.
5. Inspect air cleaner for damage or leaks. Check element and replace as needed.
6. Check electrical charging system.
7. Check the warning lights.
8. Check tires for wear and pressure.
9. Check the Bob-Tach attachment for condition. Inspect the wedges for damage or wear.
10. Inspect Operator Cab, Seat Belt, Seat Bar, Safety Treads, Lights, Horn, Safety Signs (Decals), Brake, etc.
11. Inspect for loose or broken parts or connections.
12. Operate the loader and check all functions.
13. Inform the Owner/Operator of any items that need service.

PREVENTIVE  
MAINTENANCE

HYDRAULIC  
SYSTEM

HYDROSTATIC  
SYSTEM

DRIVE  
SYSTEM

MAIN  
FRAME

ELECTRICAL  
SYSTEM

ENGINE  
SERVICE

TECHNICAL  
DATA

## CONTENTS

SAFETY INSTRUCTIONS . . . . .	i
FIRE PREVENTION . . . . .	ii
SERIAL NUMBER LOCATIONS . . . . .	iii
ARRIVAL CONDITION REPORT . . . . .	iii
DELIVERY REPORT . . . . .	iii
BOBCAT LOADER IDENTIFICATION . . . . .	iv
PREVENTIVE MAINTENANCE . . . . .	1
HYDRAULIC SYSTEM . . . . .	2
HYDROSTATIC SYSTEM . . . . .	3
DRIVE SYSTEM . . . . .	4
MAIN FRAME . . . . .	5
ELECTRICAL SYSTEM . . . . .	6
ENGINE SERVICE . . . . .	7
SPECIFICATIONS . . . . .	8
TECHNICAL DATA . . . . .	9



## I. SAFETY INSTRUCTIONS

### A. SAFETY IS YOUR RESPONSIBILITY

The Bobcat Loader is a highly maneuverable and compact machine. In operation, it is rugged and useful under a wide variety of conditions. This presents an operator with hazards which are common for off highway, rough terrain applications but are not unique for use of Bobcat loaders. The loader has an internal combustion engine with resultant heat and exhaust. All exhaust gases can kill so the loader must be used with adequate ventilation. The loader must not be used in an area with explosive dusts or gases or so that the engine exhaust can contact flammable material. The loader has a spark arrestor muffler which is required for operation in certain areas.

The dealer recommends the capabilities and restrictions of the loader and attachments for each application. The dealer demonstrates the safe operation of the loader according to the manufacturer's instructional materials which are also available to all operators. The dealer can also identify unsafe modifications or use of unapproved attachments. The attachments and buckets are designed for rated capacity and secure fastening to the loader. For each model loader, the user must check with the dealer or manufacturer's literature to identify each bucket or attachment for safe loads of materials of specified densities.

The following publications provide information on the safe use of the loader and attachments:

1. The Delivery Report is used to check whether complete instructions have been given to the new owner.
2. The Operator's Manual delivered with every loader gives operating information as well as routine maintenance and service.
3. Every loader has machine signs (or decals) which instruct on the safe care and operation of the loader. The complete signs and their location are shown in the Operator's Manual. All signs are available from your Bobcat dealer.
4. The loader has a plastic Operator Handbook fastened to the operator cab. It has brief instructions always available to the operator. The handbook is available from your Bobcat dealer.
5. The Service Manual and Parts Manual are optional manuals from your Bobcat dealer for use by mechanics to do shop-type service and repair work.

The dealer and owner/operator review the recommended uses of the loader and attachments at the time of delivery of the loader. If change of the use of the loader occurs, the owner/operator must remember to ask the dealer for recommendations on the new use of the loader.

### B. BEFORE OPERATING THE BOBCAT LOADER



B-7023



This Service Manual was written to give the service personnel instructions on the safe service of the Bobcat loader. **READ AND UNDERSTAND THIS SERVICE MANUAL BEFORE SERVICE YOUR BOBCAT.**

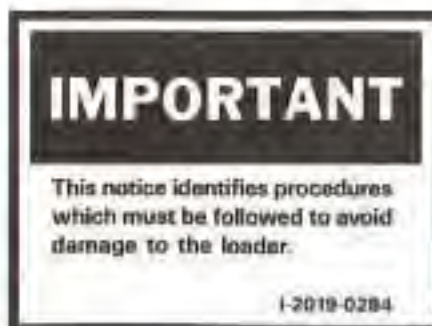



## C. SAFE OPERATION NEEDS A QUALIFIED OPERATOR

A QUALIFIED OPERATOR\* MUST DO THE FOLLOWING:

### 1. UNDERSTAND THE WRITTEN INSTRUCTIONS, RULES AND REGULATIONS

- a. The written instructions from Melroe Company include the delivery report, loader operator's handbook and manual, attachment manual and machine signs (decals).
- b. Check the rules and regulations at your location. The rules may include an employer's work safety requirements. Regulations may identify a hazard such as utility supply line.

### 2. HAVE TRAINING WITH ACTUAL OPERATION

- a. Operator training must consist of a demonstration and verbal instruction. This training is given by the Bobcat dealer before the loader is delivered.
- b. The new operator should start in an area without bystanders and use all the controls until he can control the loader at full use under the conditions for his work area.

### 3. KNOW THE WORK CONDITIONS

- a. For each material to be handled, the operator must know how to avoid exceeding the rated operating capacity of the loader. For example, he must know whether he can safely take a full load or just part of a bucket load when handling certain loose material with a given bucket.
- b. The operator must know any prohibited uses or work areas for the loader. For example, he needs to know about excessive slopes.

- \* For an operator to be qualified, he must not use drugs or alcoholic drinks which change his alertness or coordination while working. An operator who is taking prescription drugs must get medical advice on whether or not he can safely operate a machine.

## II. FIRE PREVENTION

The loader has several components which are at high temperature under normal operating conditions. The primary source of high temperatures is the engine and exhaust system. The electrical system, if damaged or incorrectly maintained, can be a source of arcs or sparks. These conditions make it necessary to avoid applications where explosive dust or gases can be ignited by arcs, sparks or heat.

Flammable debris (leaves, straw, etc.) must be removed regularly. If flammable debris is allowed to accumulate, it will increase the condition for fire hazard. The loader must be cleaned as often as necessary to avoid this accumulation. This flammable debris in the engine compartment can be a fire hazard when the loader is parked with a hot engine.

The spark arrester muffler is designed to control the emission of hot particles from the engine and exhaust system, but the muffler and the exhaust gases are still hot. This spark arrester muffler does not change the need to avoid use of the loader in an atmosphere with explosive dust or gases or where the exhaust can contact flammable material.

1. Do not use the Bobcat loader in applications where explosive dust or gases can be ignited by arcs, sparks, hot components or exhaust gases.
2. The operator cab, engine compartment and engine cooling system must be inspected every day and cleaned if necessary to prevent overheating. Remove all flammable material.
3. Check all electrical wiring and connections for damage. Keep the battery terminals clean and tight. Repair or replace any damaged part.
4. Check for damage and leakage at all the fuel, oil and hydraulic tubes, hoses and fittings. Tighten or replace any that show leakage. Always clean fluid spills.
5. Use ether or starting fluids only when approved by the engine manufacturer. Do not use ether or starting fluids on any engine which has glow plugs. These starting aids can cause an explosion and injure bystanders.
6. Always clean the loader before doing any welding. Cover rubber hoses, battery and all other flammable parts. Keep a fire extinguisher near the loader when welding.
7. Stop the engine and let it cool before adding fuel. No smoking.
8. Use the procedure in Operator's Manual for connecting and charging batteries.
9. Use the procedure in Operator's Manual for servicing the spark arrester muffler.





## V. BOBCAT LOADER IDENTIFICATION

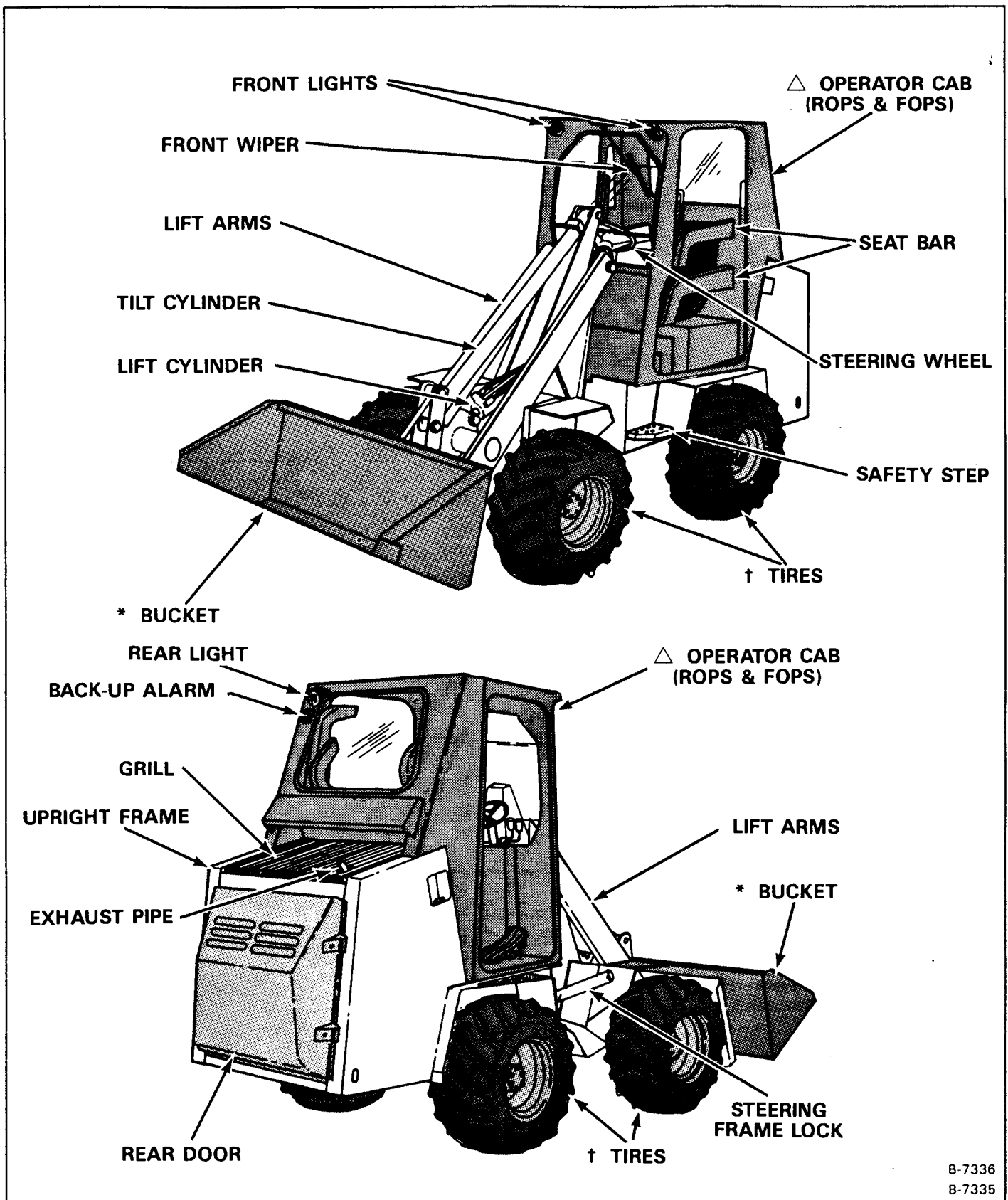

\* BUCKET — Several different buckets and other attachments are available for the Bobcat loader.

† TIRES — Tires shown are optional flotation tires which are not standard for this loader.

△ ROPS, FOPS — Roll Over Protective Structure, Falling Object Protective Structure.

B-7336

B-7335

## PREVENTIVE MAINTENANCE

## PREVENTIVE MAINTENANCE

	Paragraph Number	Page Number
AIR CLEANER . . . . .	1-6	1-3
ALTERNATOR BELT ADJUSTMENT . . . . .	1-10	1-8
AXLES, Front and Rear . . . . .	1-14	1-14
BACK-UP ALARM . . . . .	1-18	1-17
ELECTRICAL SYSTEM . . . . .	1-11	1-8
Battery Replacement . . . . .	1-11.3	1-11
Electrical System Service . . . . .	1-11.1	1-9
Using an Extra Battery . . . . .	1-11.2	1-9
ENGINE COOLING SYSTEM . . . . .	1-9	1-8
Coolant Level . . . . .	1-9.1	1-8
Coolant Replacement . . . . .	1-9.2	1-8
ENGINE LUBRICATION SYSTEM . . . . .	1-8	1-6
Engine Oil and Filter Replacement . . . . .	1-8.1	1-7
FRAME LOCK . . . . .	1-3	1-2
FUEL SYSTEM . . . . .	1-7	1-4
Filling the Fuel Tank . . . . .	1-7.1	1-4
Fuel Filter . . . . .	1-7.2	1-5
Removing Air From the Fuel System . . . . .	1-7.3	1-6
HYDRAULIC/HYDROSTATIC SYSTEM . . . . .	1-12	1-11
Checking and Adding Fluid . . . . .	1-12.1	1-11
Hydraulic Fluid Replacement . . . . .	1-12.4	1-12
Hydraulic/Hydrostatic Filter Replacement . . . . .	1-12.3	1-12
Hydraulic/Hydrostatic Fluid Reservoir . . . . .	1-12.2	1-11
LIFT ARM STOP . . . . .	1-2	1-2
LIFTING AND BLOCKING THE LOADER . . . . .	1-4	1-2
LOADER LUBRICATION . . . . .	1-17	1-16
OPERATOR CAB . . . . .	1-19	1-17
REAR DOOR . . . . .	1-5	1-3
Door Latch Adjustment . . . . .	1-5.1	1-3
SERVICE SCHEDULE . . . . .	1-1	1-1
SPARK ARRESTOR MUFFLER . . . . .	1-13	1-13
TIRE MAINTENANCE . . . . .	1-16	1-15
Wheel Nuts . . . . .	1-16.1	1-15
U-JOINTS . . . . .	1-15	1-15



## 1-1 SERVICE SCHEDULE

The service schedule is a guide for correct maintenance of the Bobcat loader that must be done regularly. Always use these service intervals unless very hot, cold, dusty or corrosive conditions operating conditions make it necessary to increase the frequency of service. Failure to do so will cause damage to the loader or the engine.

### WARNING

Instructions are necessary before doing service on loader. See warnings and instructions both at beginning and throughout this manual. After doing service or making repair or adjustment, always check function of loader. Failure to obey warnings can cause injury or death.

W-2048-0284

SERVICE SCHEDULE		HOURS					
ITEM	SERVICE REQUIRED	8-10	50	100	250	500	1000
Engine Oil	Check the oil and add as needed.	■					
Engine Air Cleaner	Check the condition indicator. Make inspection of the air cleaner system. Replace the outer element when the red ring shows in the indicator window.	■					
Tires	Check tires for damage and correct air pressure.	■					
Seat Belt & Seat Bar	Check the condition and correct operation.	■					
All Pivot Points	Add lubricant to all fittings (See Page 1-16).	■					
Engine Coolant System	Check coolant level and add as needed. Remove any debris from cooling fins, shrouds and grills.	■					
Safety Signs (Decals)	Check for damaged decals. Replace any decals that are not in correct location or are damaged.	■					
Hydraulic Fluid	Check the fluid level and add the recommended fluid as needed.	■					
Wheel Nuts	▲ Check for loose wheel nuts. Tighten to correct torque if loose.		■				
Steering Cylinder and Articulation Link	Lubricate rear fittings (2) with approved grease.		■				
Fuel Filter	Remove any trapped water.		■				
Batteries	Check the battery cables and the water level of the batteries.		■				
Hydraulic Control Levers	Check both levers for correct operation. Make repairs and adjustments as needed.		■				
Bob-Tach	Check the locking levers and wedges for condition and correct operation.		■				
Brake and Control Pedals	Check for correct operation. Make adjustment as necessary.		■				
Head Bolts	* Tighten to correct torque.		■				
Alternator Drive Belt	Check condition and tension of the belt.		■				
Engine Oil & Filter	Replace oil and filter.		■				
Spark Arrestor Muffler	Empty spark chamber.			■			
U-Joints (Drive Shaft)	Lubricate with a good quality grease.			■			
Hydraulic Filter	Replace the right hand filter (S/N 12999 & Below).			■			
Fuel Filter	Replace the filter element.				■		
Front & Rear Differentials	Check oil level and add oil as needed.				■		
U-Joint (Engine to Hydrostatic Pump)	Add grease to fittings.				■		
Hydraulic/Hydrostatic System	● Replace the reservoir breather and oil filters				■		
Bronze Filter (40 Micron)	Change the 40 micron filter in the hydrostatic port block.					■	
Hydraulic/Hydrostatic System	Replace the fluid and filters. Clean the cap and vent (S/N 13126 & Below). Replace the fluid and filters. Drain the reservoir (S/N 13127 & Above).						■

▲ Check the wheel nut torque every 8 hours for the first 24 hours of operation.

\* Tighten after first 50 hours of operation only (re-adjust valves). This procedure must be done by qualified service personnel.

● Also replace the lefthand filter when the transmission warning light stays on for five (5) minutes after the hydrostatic fluid is at operating temperature.

### 1-2 LIFT ARM STOP (Fig. 1-1)

**⚠ WARNING**

Never work on loader with lift arms up unless lift arms are held by a lift arm stop. Failure to obey warnings can cause injury or death.

W-2059-0284

**NOTE:** Lift arm stops are available from your local Bobcat dealer.

- (1) One person must stay in the operator's seat, with the seat belt fastened and the seat bar lowered, while another person installs the lift arm stop.
- (2) Start the engine and raise the lift arms all the way up.
- (3) Have a second person install the lift arm stop over the rod of the lift cylinder.

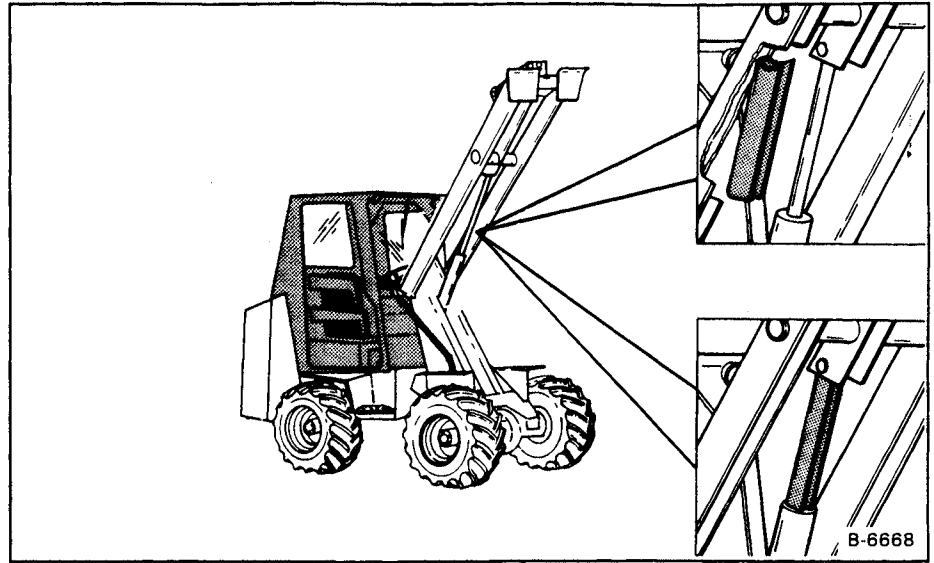

Fig. 1-1 Lift Arm Stop

### 1-3 FRAME LOCK

Before any service or repair work is done on the Bobcat loader, always connect the steering frame lock (Fig. 1-2).

**⚠ WARNING**

Keep everyone away from the pivot area when the steering frame lock is not in locked position. Failure to obey warnings can cause injury or death.

W-2022-0284

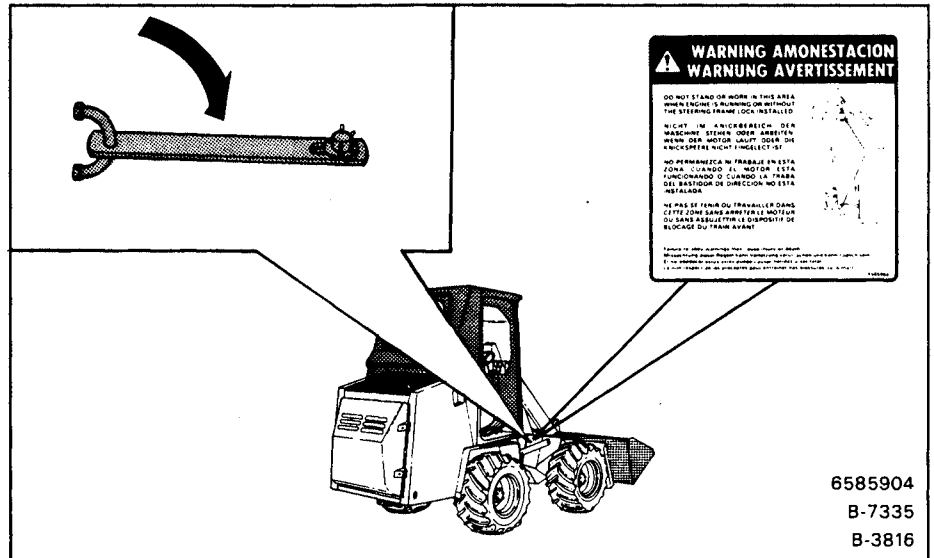

Fig. 1-2 Steering Frame Lock

### 1-4 LIFTING AND BLOCKING THE LOADER

**⚠ WARNING**

Loader can fall during some service. Put jackstands under both front axles and both rear corners of frame. Failure to obey warnings can cause injury or death.

W-2017-0284

Before performing service or maintenance procedures on the Bobcat loader, lift it up and block it.

- (1) Lower the lift arms. Stop the engine and install the frame lock.
- (2) Put a floor jack under the rear of the loader.



(3) Lift the loader with the floor jack and put a jackstand under each rear corner of the loader. The loader must be level.

(4) Put the floor jack under the center of the front axle.

(5) Lift the loader with the floor jack and put a jackstand under each side of the front axle. The loader must be level.

## **⚠ WARNING**

Do not stand on front wheels. Front wheels turn freely when loader is lifted. Failure to obey warnings can cause injury or death.

W-2028-0284

### 1-5 REAR DOOR

## **⚠ WARNING**

Stop, cool and clean engine of flammable material. Never service or adjust loader with engine running unless instructions in manual require engine running. Failure to obey warnings can cause injury or death.

W-2061-0284

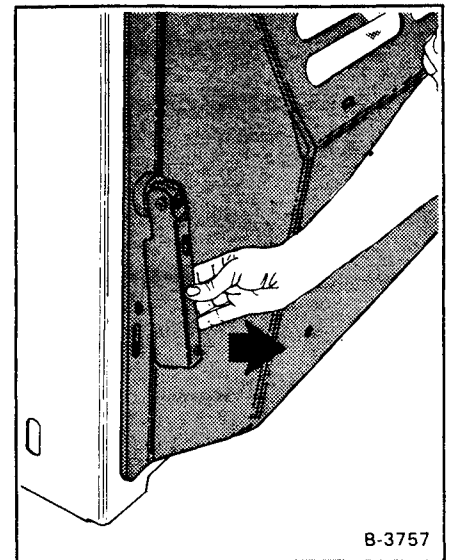

Fig. 1-3 Releasing Rear Door

Pull the door latch up and turn it to the left to open the rear door (Fig. 1-3).

## **⚠ WARNING**

Keep rear door closed except for service. Failure to obey warnings can cause injury or death.

W-2020-0284

### 1-5.1 Door Latch Adjustment

(1) Loosen the set screw (Fig. 1-4). Loosen the nut (Fig. 1-5, Item 1).

(2) Turn the bolt (Fig. 1-5, Item 2) in or out until the door contacts both the top and the bottom of the loader frame with the lever in the latched position (Fig. 1-6, Item 1).

**NOTE:** It take approximately 50 lbs. of force to push the lever down when the latch is correctly adjusted.

(3) Lubricate the wear surface of the latch (Fig. 1-6, Item 2).

**NOTE:** With the set screw up, the flanges on the bolt (Fig. 1-6, Item 3) must be to the side so that the set screw aligns with the flat surface at the end of the bolt.

(4) Tighten the set screw (Fig. 1-4). Tighten the nut (Fig. 1-5, Item 1) to 65 - 70 ft.-lbs. (88 - 95 Nm) torque.

### 1-6 AIR CLEANER

See the Service Schedule (Page 1-1) for the interval to service the air cleaner system.

(1) Empty the dust cup.

(2) Check the air intake hoses for wear. If the air cleaner is damaged, check all the connections. Replace all damaged components.

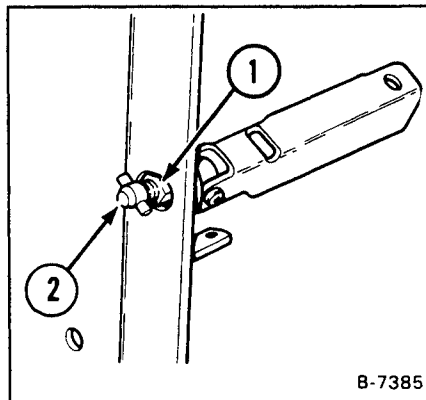

Fig. 1-5 Door Latch

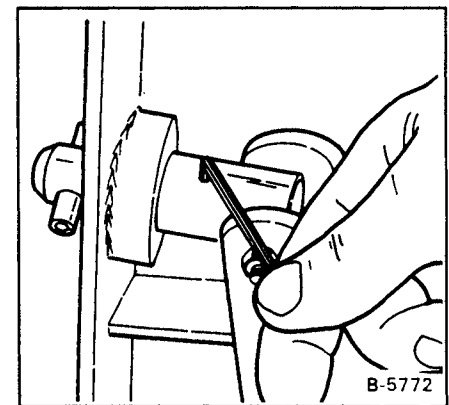

Fig. 1-4 Set Screw

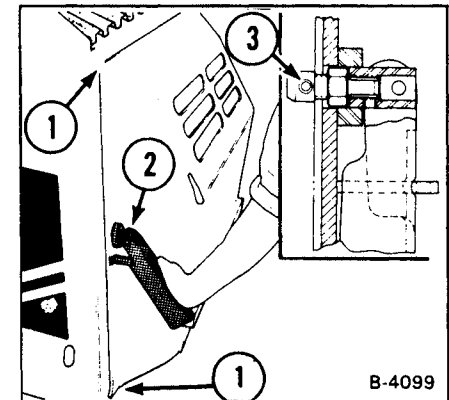

Fig. 1-6 Rear Door

(3) Replace the large (outer) filter element only when the red ring shows in the window of the condition indicator (Fig. 1-7).

(4) Replace the inner filter element every third time the outer filter is replaced or when the red ring still shows in the indicator window after the outer filter is replaced.

Use the following procedure to replace the filter element(s).

**NOTE:** Before replacing the filter element, push the button on the condition indicator (Fig. 1-7, Item 1) and start the engine. If the red ring does not show, do not replace the filter element.

(1) Stop the engine.

(2) Loosen the clamp on the dust cup (Fig. 1-8, Item 1). Remove the dust cup and the outer element (Fig. 1-8, Item 2). Do not remove the inner element (Fig. 1-8, Item 3) unless it must be replaced as indicated above.

(3) Remove the rubber boot (Fig. 1-8, Item 4) and empty the dust cup.

(4) Clean the inside of the filter housing so that the element has a smooth surface to contact at the seal (Fig. 1-8, Item 5). A tight seal is necessary to avoid corrosion, especially when the loader is operated in a highly corrosive application (Example: Fertilizer handling).

(5) Install the new filter element(s).

**NOTE:** The washer (Fig. 1-8, Item 6) must be under the wing nut.

(6) Install the dust cup and tighten the clamp. All hoses and clamps must be tight.

(7) Push the button at the indicator (Fig. 1-7, Item 1) to remove the red ring.

(8) Record the operating hours of the loader on the decal (Fig. 1-9, Item 1).

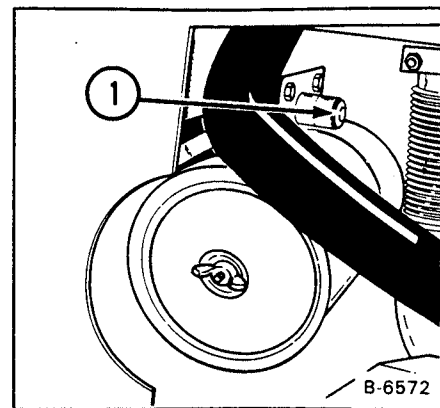

Fig. 1-7 Condition Indicator

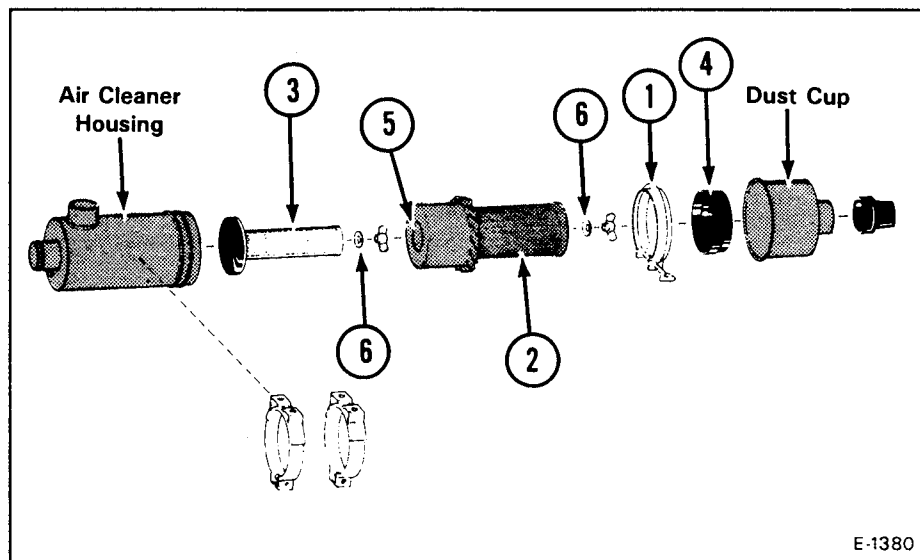

Fig. 1-8 Air Cleaner Assembly

## 1-7 FUEL SYSTEM

Use number 2 diesel fuel in the engine. During very cold temperatures, number 1 fuel can be used.

### 1-7.1 Filling the Fuel Tank

(1) Remove the filler cap (Fig. 1-10, Item 1). The key switch must be in the "OFF" position and the engine must be cool.

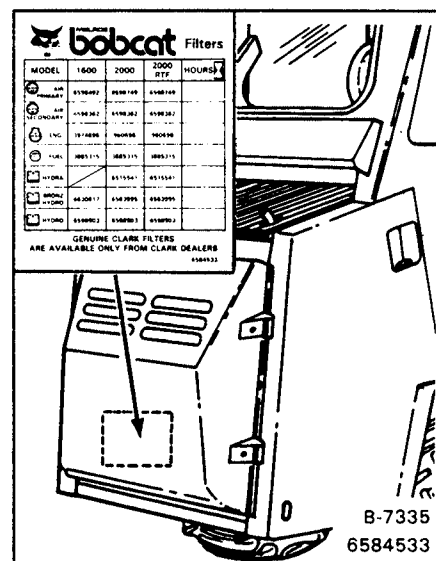

Fig. 1-9 Filter Decal

⚠
**WARNING**

Stop and cool engine before adding fuel.  
**NO SMOKING!** Failure to obey warnings  
 can cause injury or death.

W-2063-0284

(2) Use clean fuel of the correct specification from a clean, approved safety container. Fill the tank only in an area that has a free movement of air and no open flames or sparks (Fig. 1-11).

(3) The cap must be clean before it is installed on the fuel tank and tightened (Fig. 1-9, Item 1).

### 1-7.2 Fuel Filter

The fuel filter is at the front left of the engine (Fig. 1-12). See the Service Schedule (Page 1-1) for the service interval for the water trap and the fuel filter element.

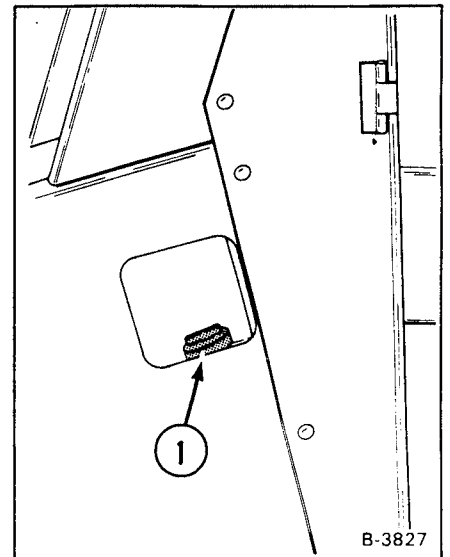

Fig. 1-10 Fuel Fill Location

Use the following procedure to check the water trap.

(1) If there is water in the trap at the bottom of the filter, loosen the thumb screw (Fig. 1-12, Item 1) to remove the adapter.

(2) Tighten the thumb screw after all the water is removed.

Use the following procedure to replace the fuel filter element.

(1) Clean the area around the fuel filter. Put a clamp on the fuel supply hose from the fuel tank.

(2) Remove the thumb screw at the bottom of the filter and drain the fuel from the filter.

(3) Remove the small bolt at the top of the filter head (Fig. 1-12, Item 2) while holding the nut below the filter bowl. Remove the filter bowl.

(4) Remove the filter element (Fig. 1-12, Item 3) and discard it.

(5) Check the condition of the seals. Replace as needed.

(6) Install a new filter element with the bowl, nut and thumb screw. Tighten the thumb screw finger tight only. Remove the clamp.

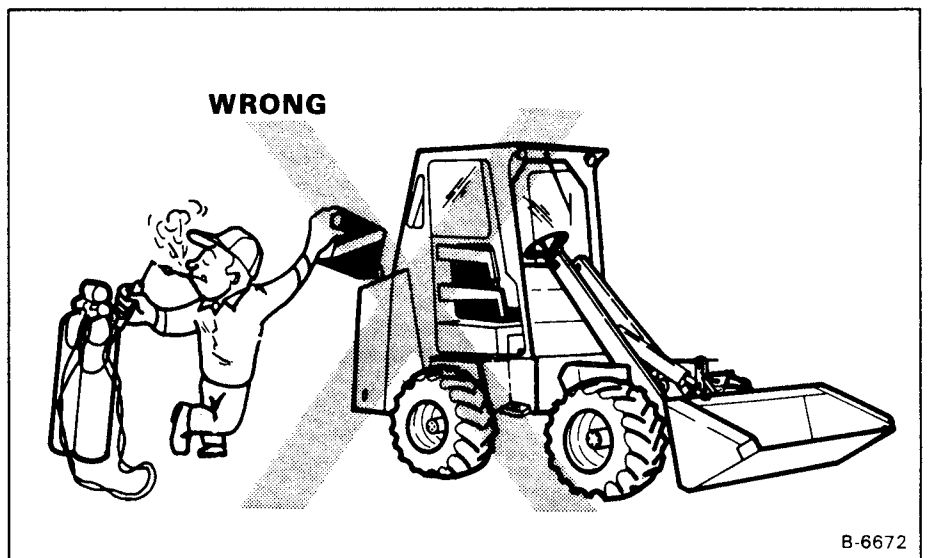

Fig. 1-11 Fuel Fill Warning

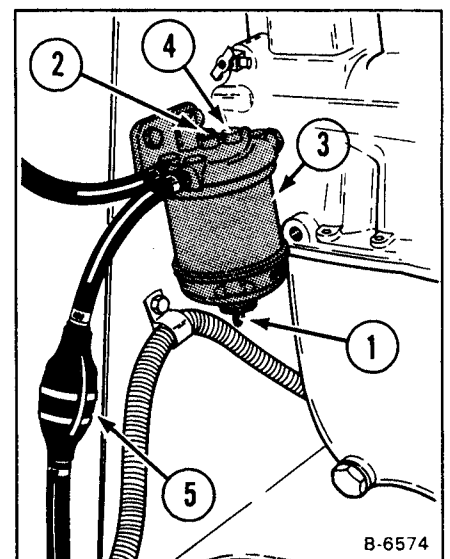

Fig. 1-12 Fuel Filter

**Dear**

**Thanks very much for your visiting and  
patience.**

**Want to get more information,**

**Please click here, Go back to the page.**

**After your payment, you will have instant access to  
your download.**

**The Download Link will also be sent to your e-mail.**

**You will get the complete manual**

**Have any questions**

**please write to me**

**[admin@servicemanualperfect.com](mailto:admin@servicemanualperfect.com)**