

773



Bobcat®

**G-SERIES
Parts
Manual**

S/N 500K11001 & Above

S/N 518011001 & Above

S/N 518111001 - 518114999

S/N 519011001 - 519027999

S/N 519211001 - 519214999

S/N 517611001 - 517624999

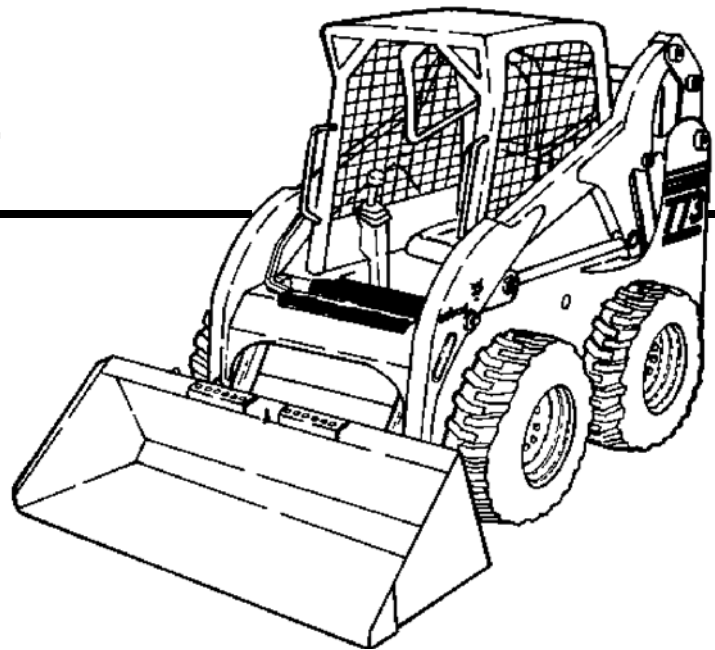

**EQUIPPED WITH
BOBCAT INTERLOCK
CONTROL SYSTEM (BICS)**

6900939 (5-05) Revised (7-09)

Printed in U.S.A.

© Bobcat Company 2009

GENERAL INFORMATION

Before ordering parts, ALWAYS provide dealer with your product model number and complete serial number information. Before ordering parts, verify correct part numbers and/or serial numbers with your dealer. When using the machine serial number, use the complete number.

Some serial number breaks are not available at time of printing. These are listed as & Bel or & Abv or - (thru)

The number shown in the quantity column in this manual is the number of parts needed for the illustration on the page. For some parts an “x” will be shown in the quantity column. This “x” indicates that the quantity to be used is “As Needed”.

When references LH (Left Hand) and RH (Right Hand) are used in this manual, it is done from the operator’s seat in the forward operating position.

When “See Illustration....” appears in the remarks column, refer to the contents page for the illustration title to find page number location.

Some of the illustrations and information found in this parts manual were supplied to Bobcat by machine component companies.

For additional information on the Bobcat website visit www.bobcat.com

ABBREVIATIONS

SALES = Order from Gwinner Sales Department	PM = Parts Manual
NSS = Not Serviced Separately	S/L = Service Letter
NAP = Not Available as Parts	W/ = With
BTI = Bobcat Technical Information Bulletin	W/ O= Without
OM = Operation & Maintenance Manual	ID = Inside Diameter
SM = Service Manual	OD = Outside Diameter
AHC = Advanced Hand Controls	“ = Inches
ACS = Advanced Control System	’ = Feet
SJC = Selectable Joystick Controls	MM = Millimeters

TRANSLATION KITS & DECAL KITS

AR = Argentina (Spanish) BR = Brazil (Portugese) JP = Japanese
(Translation Kit includes Safety Manual, Operators Manual & Decal Kit)

DISPOSITION

(Found in the Remarks Column)

[A]	=	Use Up
[B]	=	Use Up on Other Applications
[C]	=	File PDR Report with Bobcat Parts Sales
[D]	=	Part Number Error

NOTE D'INFORMATION

Pour toute référence au numéro de série de l'engin, toujours donner le numéro complet.

Le chiffré apparaissant dans la colonne des quantités de ce manuel représentent le nombre de pièces nécessaires pour l'illustration reprise sur la page. Dans certains cas, on lira un "x" dans la colonne des quantités. Cet "x" indique que la quantité nécessaire est "selon besoin".

Pour toute référence vers la GAUCHE ou la DROITE dans ce manuel, considérer que la personne se trouve assise dans le siège de l'opérateur, en position de fonctionnement en marche avant.

Certaines illustrations et informations reprises dans ce manuel de pièces de rechange ont été fournies à Bobcat/Ingersoll-Rand par des fabricants de composants.

ABREVIATIONS & SYMBOLES

SALES	= Commander au Service Ventes à Bruxelles
NSS	= Pas vendu séparément
NAP	= Non disponible comme pièce de rechange
*	= Chapitre, page ou numéro de pièce modifié ou supplémentaire
BTI	= Bobcat Technical Information Bulletin : voir à la fin de la microfiché du modèle concerné ou la microfiche générale reprenant l'ensemble des "BTI".
was 6535403	= était avant 6535403
adj. (adjustment)	= réglage
Assembly	= ensemble
available W/Ref.	= disponible avec réf.
bulk/sold per foot	= en vrac/vendu par pied
does not include	= ne comprend pas
included with	= compris dans
I.D.	= D.I. (diamètre intérieur)
O.D.	= D.E. (diamètre extérieur)
not in kit	= pas en kit
W/ - WO/	= inclus/ - non inclus/
Qty	= quantité requise
see page/ref.	= voir page/réf.
used with ref/	= utilisé avec réf.
0,05 inch thickness	= 0,05 pouce d'épaisseur (un pouce = 25.4 mm)
weld on	= à souder

ALLGEMEINE INFORMATIONEN

Bei Angabe der Maschinen-Seriennummer stets die komplette Nummer angeben.

Bei der in der Mengenspalte (Anzahl) in diesem Handbuch angegebenen Zahl handelt es sich um die Anzahl von Teilen, die für die Abbildung auf der betreffenden Seite benötigt werden. Bei manchen Teilen in der Mengenspalte ist ein "x" angegeben. Dieses "x" weist darauf hin, dass sich die Anzahl der verwendeten Teile auf den "Bedarf" bezieht.

Bei Verwendung der Seitenangaben links und rechts in diesem Handbuch gelten diese für die Blickrichtung vom Fahrersitz aus, und zwar in Vorwärts-Betriebsrichtung.

Einige der in diesem Ersatzteihandbuch aufgeführten Abbildungen und Informationen wurden der Bobcat/Ingersoll-Rand von den Herstellern von Maschinenbauteilen zur Verfügung gestellt.

ABKÜRZUNGEN UND SYMBOLE

SALES	= Bestellung bei der Verkaufsabteilung in Brüssel
NSS	= Nicht einzeln erhältlich
NAP	= Nicht als Ersatzteil erhältlich
*	= Geänderte oder hinzugefügte Abschnitte, Seiten oder Teilenummern
BTI	= Bobcat Technical Information Bulletin : Siehe am Ende der Mikrokarte des jeweiligen Modells oder der allgemeinen Mikrokarte der BTI.
was 6535403	= War 6535403
adj.	= Einstellung
Assembly	= Baugruppe
available W/Ref.	= erhältlich mit der Referenz
bulk/sold per foot	= Mengenabnahme / Verkauf pro Fuss
does not include	= beinhaltet nicht
included with	= enthalten in
I.D.	= Innendurchmesser
O.D.	= Aussendurchmesser
not in kit	= nicht in Bausatz
W/ - WO/	= mit/ - ohne/
Qty	= Anzahl
see page/ref.	= Siehe Seite / Referenz
used with ref.	= verwendet mit Referenz
0.05 inch thickness	= Dicke : 0.05 Zoll (ein Zoll = 25.4 mm)
weld on	= anschweißen

INFORMAZIONI GENERALI

Quando si usa il numero di serie della macchina usare il numero completo.

Il numero mostrato nella colonna della quantità di questo manuale corrisponde al numero di componenti necessari per l'illustrazione della pagina. Per alcuni componenti appare "X" nella colonna delle quantità. Questa "X" indica che la quantità da usare è "come necessario".

See in questo manuale si fa riferimento alla parte destra o sinistra, si intende dal sedile dell'operatore nella posizione in avanti di funzionamento.

Alcune delle illustrazioni e informazioni trovate in questo manuale di componenti sono state fornite alla Bobcat/Ingersoll-Rand da società di componenti di macchine.

SIMBOLI E ABBREVIAZIONI

SALES	= Ordinare al servizio vendite di Bruxelles
NSS	= Non vendute separatamente
NAP	= Non disponibile come componente
*	= Sezioni, pagine o numeri di componente cambiati o aggiunti
BTI	= (Bobcat Technical information) Ved. al termine del microfiche del modello relativo oppure microfiche generale
was 6535403	= era 6535403
adj. (adjustment)	= regol. (regolazione)
Assembly	= Complessivo
available W/Ref.	= disponibile con rif.
bulk/sold per foot	= alla rinfusa/venduto al piede
does not include	= non comprende
Included with	= compreso con
I.D.	= d. i.
O.D.	= d. e.
not in kit	= non fa parte del kit
W/ - WO/	= con - senza
Qty	= Qtà
see page/ref	= ved. pagina/rif.
used with ref.	= usato con il rif.
0,05 inch thickness	= spessore 0,05 pollici (un pollice = 25,4 mm)
weld on	= a saldare

INFORMACION GENERAL

Al utilizar el número de serie de la máquina, debe emplearse el número completo.

El número que figura en la columna de “Unidades” en este manual es el número de piezas que se necesitan para la ilustración que consta en la página. En algunas piezas aparece una “x” en la columna de “Unidades”. Esta “x” indica que las unidades a utilizar son “según sea necesario”.

Cuando se empleen las referencias izq. y dcha., éstas se entienden mirando desde el asiento del conductor, en posición de marcha adelante.

Algunas de las ilustraciones y la información que figuran en este manual de piezas han sido facilitadas a Bobcat/Ingersoll-Rand por empresas de componentes de máquinas.

ABREVIATURAS Y SIMBOLOS

VENTAS	= Pedido al Departamento de Ventas de Bruselas
NSS	= No se vende por separado
NAP	= No disponible como pieza de repuesto
*	= Secciones, páginas o referencias modificadas o añadidas
BTI	= (Bobcat Technical Information) Ver al final de la microficha del modelo afectado o en la microficha general “Boletín de Información Técnica Bobcat”.
was 6535403	= era anteriormente el 6535403
adj. (adjustment)	= ajuste
assembly	= conjunto
available W/Ref.	= disponible con la ref.
bulk/sold per foot	= a granel/vendido por pies
does not include	= no incluye
included with	= incluido en
I.D.	= diámetro interior
O.D.	= diámetro exterior
not in kit	= no en el kit
W/ - WO/	= con/ - sin
Qty	= Unidades
see page /ref.	= ver página/ref.
used with ref.	= empleado con la ref.
0,05 inch thickness	= 0,05 pulgadas de espesor (1 pulgada = 25,4 mm)
weld on	= debe ser soldado

ALGEMENE INFORMATIE

Als u het serienummer van de machine gebruikt, geef dan het gehele serienummer.

Het cijfer dat voorkomt in de kolom "Aantal", in deze handleiding, is het aantal onderdelen dat nodig is van de illustratie op de pagina. Voor sommige onderdelen staat er een "x" in de kolom "Aantal". Deze "x" betekent dat er een aantal "zoals nodig" vereist is.

Wanneer er in deze handleiding naar "links" en naar "rechts" gerefereerd wordt, moet dit verstaan worden voor een bestuurder die in de bestuurdersstoel zit in de voorwaartse bedrijfsstand.

Sommige van de illustraties en informatie in deze onderdelen-handleiding werden door firma's van machine-componenten geleverd aan Bobcat/Ingersoll-Rand.

AFKORTINGEN EN SYMBOLEN

SALES	= Bestellen bij de Verkoopafdeling te Brussel
NSS	= Niet afzonderlijk te verkrijgen
NAP	= Niet beschikbaar als onderdeel
*	= Gewijzigde of toegevoegde paragrafen, pagina's of onderdeelnummers
BTI	= Bobcat Technical Information Bulletin : Zie einde van de microfiche van het desbetreffende model of einde van de algemene microfiche die het geheel van alle "BTI" herneemt.
was 6535403	= was vroeger 6535403
adj. (adjustment)	= afstelling
Assembly	= geheel
available W/Ref.	= beschikbaar met ref.
bulk/sold per foot	= bulk/aan de meter verkocht
does not include	= bevat niet
includes with	= is bevat in
I.D.	= ϕ inw. (inwendige diameter)
O.D.	= ϕ uitw. (uitwendige diameter)
not in kit	= niet in de kit
W/ - WO/	= met/ - zonder/
Qty	= vereiste aantal
see page/ref.	= zie pagina/ref.
used with ref/	= gebruikt met ref.
0,05 inch thickness	= 0.05 inch dik (een inch = 25.4 mm)
weld on	= te lassen

**Use only Bobcat belts and hoses
to maintain maximum service life.**

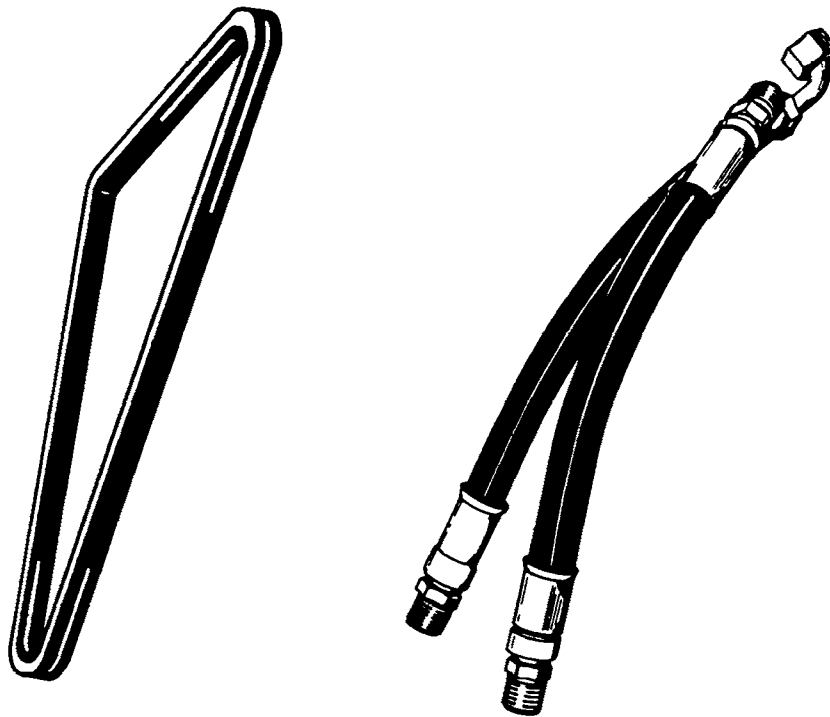

Available from Bobcat Parts.



CONTENTS

MAINTENANCE ITEMS	1-2
MAINTENANCE ITEMS	1
MAIN FRAME	3-32
SEAT & SEAT BAR	11
SEAT	13
PANELS	15
REAR DOOR	17-20
LIFT ARMS & BOB-TACH	21-26
BOB-TACH	27
FUEL SYSTEM	29-32
MAIN FRAME	3-6
OPERATOR CAB	7-10
DRIVE TRAIN	33-44
DRIVE TRAIN	33
AXLE	35
MOTOR CARRIER	37
DISC BRAKE	39-44
HYDRAULIC SYSTEM	45-146
BICS CONTROL VALVE	141
MANUAL LIFT RELEASE VALVE	143
PRESSURE RELEASE VALVE	145
HYDRAULIC CIRCUITRY	45-68
MANUAL LIFT RELEASE SYSTEM	69
AUXILIARY HYDRAULICS	71-80
TILT CYLINDER	81-86
LIFT CYLINDER	87-92
CONTROL PEDALS	93
HYDRAULIC CONTROL VALVE	95-140
HIGH FLOW HYDRAULICS	147-162
HIGH FLOW HYDRAULICS	147-162
HYDROSTATIC SYSTEM	163-206
HYDROSTATIC CIRCUITRY	163-178
HAND CONTROLS	179-182
HYDROSTATIC MOTOR	183-186
HYDROSTATIC PUMP	187-198
GEAR PUMP	199-202
HYDROSTATIC OIL FILTER	203-206
ELECTRICAL SYSTEM	207-250
CAB ELECTRICAL CIRCUITRY	207-210
ENGINE ELECTRICAL CIRCUITRY	211-218
CONTROLS ELECTRICAL	219-242
ALTERNATOR	243-246
STARTER	247-250
POWER UNIT	251-368
COOLING SYSTEM	251-254
ENGINE & ATTACHING PARTS	255-268
THROTTLE	269
COOLING FAN DRIVE ASSY.	271-274
ENGINE & GASKET KITS	275-320
GEARCASE	279-322
CRANKCASE	281-328
ROCKER ARM COVER	283-330

CONTENTS (Cont'd)

POWER UNIT

VALVE ROCKER ARM	285-332
CYLINDER HEAD	287-334
OIL PAN	289-336
PISTON & CRANKSHAFT	291-338
FUEL CAMSHAFT	293-340
CAMSHAFT	295-342
WATER PUMP	297-344
WATER FLANGE & THERMOSTAT	299-346
MANIFOLDS	301-348
ENGINE STOP LEVER	303-354
GOVERNOR	305-356
SPEED CONTROL PLATE	307-358
FUEL & INJECTION PUMPS	309-360
INJECTION PUMP	311-362
INJECTOR NOZZLES	313-364
INJECTOR HOLDER	315-366
OIL COOLER	323-326
TURBO CHARGER	349
OIL PIPE	351
AIR CLEANER	367

REPLACEMENT ENGINE 369-446

ENGINE & GASKET KITS	369-406
GEARCASE	371-408
OIL PAN	373-420
CRANKCASE	375-412
ROCKER ARM COVER	377-414
VALVE ROCKER ARM	379-416
CYLINDER HEAD	381-418
PISTON & CRANKSHAFT	383-422
FUEL CAMSHAFT	385-424
CAMSHAFT	387-426
WATER PUMP	389-428
WATER FLANGE & THERMOSTAT	391-430
MANIFOLDS	393-432
ENGINE STOP LEVER	395-438
GOVERNOR	397-440
SPEED CONTROL PLATE	399-442
FUEL & INJECTION PUMP	401
INJECTOR NOZZLES	403-446
OIL COOLER	409
TURBO CHARGER	433
OIL PIPE	435
FUEL & INJECTION PUMPS	443

ACCESSORIES & OPTIONS 447-666

ACCESS COVER	447
ACCESSORIES HARNESS	449
ACS CONVERSION KIT	451
AXLE SEAL KIT	453
BACK-UP ALARM	455
BEACON	457
BLOCK HEATER	459

CONTENTS (Cont'd)

ACCESSORIES & OPTIONS

BOB-TACH LEVERS	461
BUCKET POSITIONING VALVE KIT	463-468
BUCKET POSITIONING VALVE	469
CAB DOOR	471-490
CAB ENCLOSURE	491-494
CAB WINDOWS	495-502
COUNTERWEIGHT KIT	503-506
DECALS	507-510
DELUXE CAB	511-514
DUAL BATTERY KIT	515-518
ELECTRICAL CONNECTOR KIT	519
ELECTRICAL CONTROLS KIT	521-528
ENGINE MOUNT KIT	529
EUROPEAN ACCESSORIES	531-536
EUROPEAN ACCESSORIES	537-540
FIRE EXTINGUISHER	541
F.O.P.S. KIT	543
FLASHER LIGHTS	545
GAS SPRING KIT	547
FRONT AUXILIARY	549
HAND CONTROL KIT	551-554
HEATER & A/C	555-580
HEATER	573
HORN KIT	581
LIFT KIT	583-586
LIGHT KIT	587
MUFFLER/PURIFIER KIT	589
PEDAL EXTENDERS	591
POWER BOB-TACH KIT	593-600
POWER BOB-TACH	601-614
RADIATOR SCREEN KIT	615
REAR AUXILIARY	617-630
REAR AUXILIARY VALVE	631
REAR DOOR LOCK	633
SEAL ENCLOSURE KIT	635
REAR WIPER	637
SEAT	639-642
SEAT BELT	643-648
SOUND KIT	649
SOUND OPTION	651
SOUND REDUCTION HARDHAT	653
STROBE LIGHT	655
TIRES & RIMS	657-660
WHITE DECAL KIT	661
BULK ITEMS	663-666
NUMERICAL INDEX	668-731

MAINTENANCE ITEMS

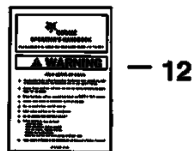
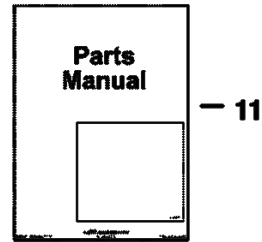
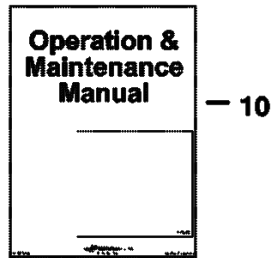
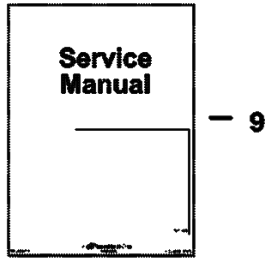
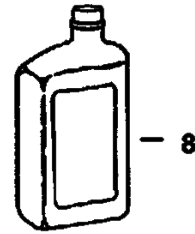
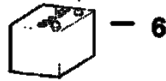
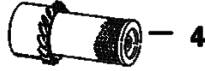
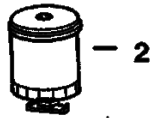
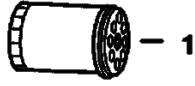

B-22668

MAINTENANCE ITEMS (Cont'd)

Ref No	Part Number	Description	Remarks	Serial Number	Qty
1	6675517	FILTER, OIL ENG	See Illustration GEARCASE/ B17146 See Illustration GEARCASE/ B13160		x
2	6667352	FILTER, FUEL W/SEPERATOR 12	See Illustration FUEL SYSTEM/ PE1627		x
3	6598362	ELEMENT	See Illustration AIR CLEANER/ B16478 - inner air cleaner		x
4	6598492	ELEMENT	See Illustration AIR CLEANER/ B16478 - outer air cleaner		x
5	6661248	FILTER, OIL HYD 12	See Illustration HYDROSTATIC OIL FILTER/ B17469 hydrostatic #3 media - 6" (152,4mm) long		x
5	6661807	FILTER, OIL HYD	See Illustration HYDROSTATIC OIL FILTER/ B13527 - in-line		x
6	6674687	BATTERY, DRY 600 AMP	See Illustration ENGINE ELECTRICAL CIRCUITRY/ PE1040R See Illustration ENGINE ELECTRICAL CIRCUITRY/ PE1104		x
7	6903117	FLUID, OIL HYD 2.5 GAL 2	Was 6563328 [A]		x
7	6903118	FLUID, OIL HYD 5 GAL	Was 6722344 [A]		x
7	6903119	FLUID, OIL HYD 55 GAL	Was 6563330 [A]		x
8	6903107	OIL, 10W30 QT. 12	Was 6657301 [A]		x
8	6903108	OIL, 10W30 GAL. 6	Was 6724557 [A]		x
8	6903112	OIL, 10W30 2.5 GAL 2	Was 6674205 [A]		x
8	6903105	OIL, 15W40 QT. 12	Was 6657299 [A]		x
8	6903106	OIL, 15W40 GAL. 6	Was 6724558 [A]		x
8	6903113	OIL, 15W40 2.5 GAL. 2	Was 6674204 [A]		x
8	6903109	OIL 30W QT. 12	Was 6657303 [A]		x
8	6903110	OIL, 30W GAL. 6	Was 6724559 [A]		x
8	6903111	OIL 30W 2.5 GAL 2	Was 6674206 [A]		x
9	6900834	MANUAL SERVICE 773 LOADER	Service Manual		1
10	6900842	MANUAL OPERATION 773/773H LOADER	Operation & Maintenance Manual		1
11	6900939	MANUAL PARTS 773 LOADER	printed		1
11	6900939-CD	MANUAL PARTS 773 LOADER CD			1
12	6718719	HANDBOOK, OPERATOR'S	See Illustration DECALS/ B17183 W/wire rope [A]		1

MAIN FRAME

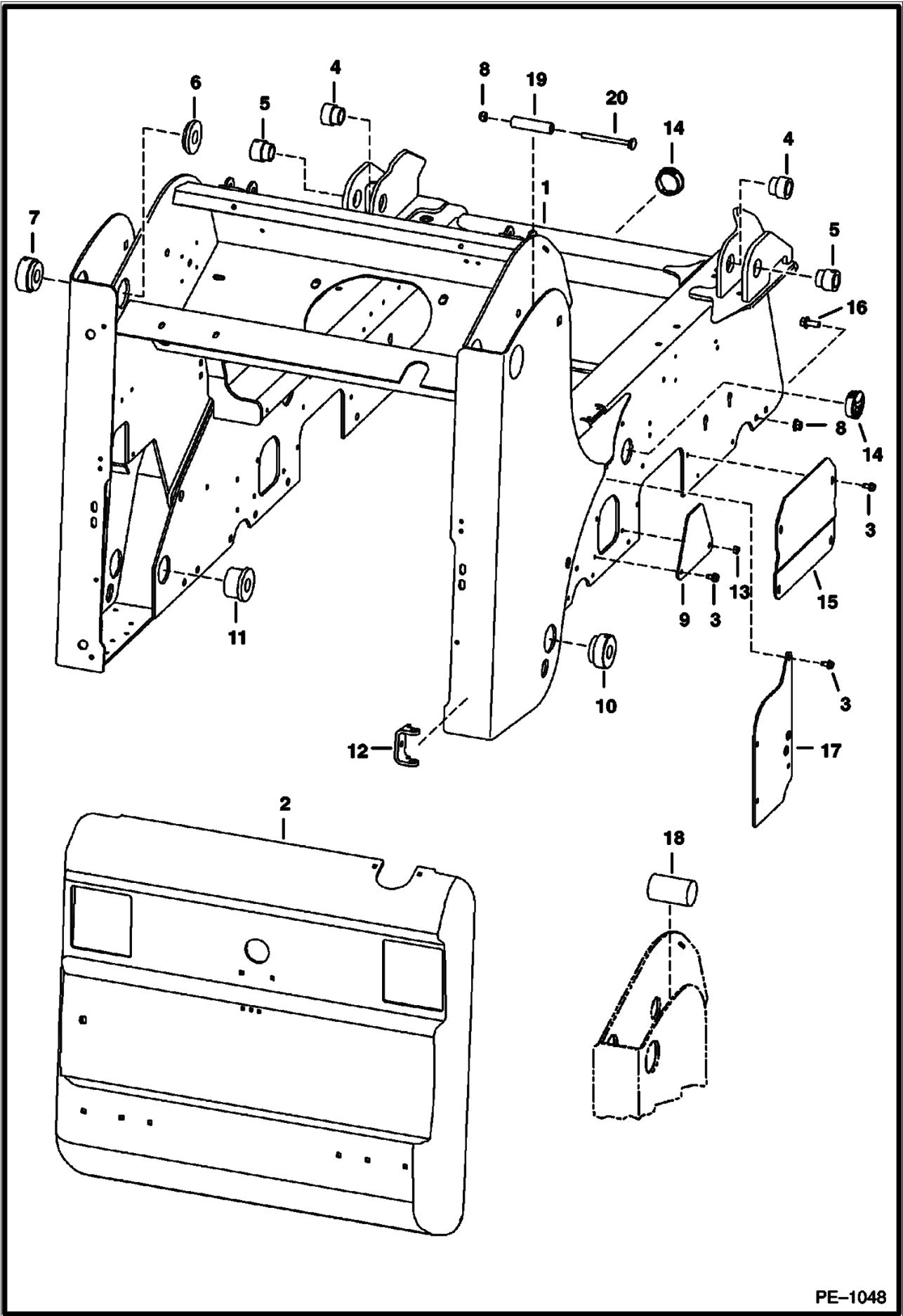

PE-1048

MAIN FRAME (Cont'd)

Ref No	Part Number	Description	Remarks	Serial Number	Qty
1	6717052	MAIN FRAME		5176 18740 & Bel	1
1	6717052	MAIN FRAME		5180 12130 & Bel	1
1	6717052	MAIN FRAME		5190 17712 & Bel	1
1	6717052	MAIN FRAME		5181 12066 & Bel	1
1	6717052	MAIN FRAME		5192 12070 & Bel	1
1		MAIN FRAME	NAP - Order 6733002 Main Frame & 2 of Ref. 15 (6719201 cover) - Was 6726150 [A]	500K 11001 & Abv	1
1		MAIN FRAME	NAP - Order 6733002 Main Frame & 2 of Ref. 15 (6719201 cover) - Was 6726150 [A]	5176 18741 & Abv	1
1		MAIN FRAME	NAP - Order 6733002 Main Frame & 2 of Ref. 15 (6719201 cover) - Was 6726150 [A]	5181 12067 & Abv	1
1		MAIN FRAME	NAP - Order 6733002 Main Frame & 2 of Ref. 15 (6719201 cover) - Was 6726150 [A]	5180 12131 & Abv	1
1		MAIN FRAME	NAP - Order 6733002 Main Frame & 2 of Ref. 15 (6719201 cover) - Was 6726150 [A]	5190 17713 & Abv	1
1		MAIN FRAME	NAP - Order 6733002 Main Frame & 2 of Ref. 15 (6719201 cover) - Was 6726150 [A]	5192 12071 & Abv	1
1	6733002	MAIN FRAME			1
2	6711524	REAR DOOR	See Illustration REAR DOOR/ TS1523		1
3	84G3712	BOLT		5176 18740 & Bel	11
3	84G3712	BOLT		5192 12070 & Bel	11
3	84G3712	BOLT		5180 12130 & Bel	11
3	84G3712	BOLT		5181 12066 & Bel	11
3	84G3712	BOLT		5190 17712 & Bel	11
3	84G3712	BOLT		500K 11001 & Abv	23
3	84G3712	BOLT		5180 12131 & Abv	23
3	84G3712	BOLT		5190 17713 & Abv	23
3	84G3712	BOLT		5192 12071 & Abv	23
3	84G3712	BOLT		5181 12067 & Abv	23
3	84G3712	BOLT		5176 18741 & Abv	23
4	6717278	BUSHING	weld on		2
5	6717277	BUSHING	weld on		2
6	6717356	BUSHING	weld on		2
7	6717357	BUSHING	weld on - flat edge		2
7	6731578	BUSHING	weld on - tapered edge		2
8	83D8	NUT 5		5176 18740 & Bel	28
8	83D8	NUT 5		5192 12070 & Bel	28
8	83D8	NUT 5		5180 12130 & Bel	28
8	83D8	NUT 5		5181 12066 & Bel	28
8	83D8	NUT 5		5190 17712 & Bel	28
8	83D8	NUT 5		500K 11001 & Abv	26
8	83D8	NUT 5		5180 12131 & Abv	26
8	83D8	NUT 5		5190 17713 & Abv	26
8	83D8	NUT 5		5192 12071 & Abv	26
8	83D8	NUT 5		5181 12067 & Abv	26
8	83D8	NUT 5		5176 18741 & Abv	26
9	6718791	COVER		5176 18740 & Bel	2
9	6718791	COVER		5180 12130 & Bel	2
9	6718791	COVER		5181 12066 & Bel	2
9	6718791	COVER		5192 12070 & Bel	2
9	6718791	COVER		5190 17712 & Bel	2
9	7136696	COVER	Was 6726069 [A]	500K 11001 & Abv	2
9	7136696	COVER	Was 6726069 [A]	5190 17713 & Abv	2
9	7136696	COVER	Was 6726069 [A]	5192 12071 & Abv	2
9	7136696	COVER	Was 6726069 [A]	5181 12067 & Abv	2
9	7136696	COVER	Was 6726069 [A]	5176 18741 & Abv	2
9	7136696	COVER	Was 6726069 [A]	5180 12131 & Abv	2

Dear

**Thanks very much for your visiting and
patience.**

Want to get more information,

Please click here, Go back to the page.

**After your payment, you will have instant access to
your download.**

The Download Link will also be sent to your e-mail.

You will get the complete manual

Have any questions

please write to me

admin@servicemanualperfect.com