

GS25, GS30, GS45, GS75 HD45, HD75, Commercial Walk-Behind Mowers

TECHNICAL MANUAL

**John Deere
Worldwide Commercial and
Consumer Equipment Division**

**TM1598 (01Nov97)
Replaces TM1598 (01Mar97)
And TM1598 (01Jul96)**

Litho in U.S.A



**GS75 Gear
54 in. Commercial
Walk-Behind Mower**



**GS45 Gear
48 in. Commercial
Walk-Behind Mower**



**GS30 Gear
36 in. Commercial
Walk-Behind Mower**



**GS25 Gear
36 in. Commercial
Walk-Behind Mower**



**HD45 Hydrostatic
36 in. Commercial
Walk-Behind Mower**



**HD75 Hydrostatic
54 in. Commercial
Walk-Behind Mower**

This technical manual is written for an experienced technician and contains sections that are specifically for this product. It is a part of a total product support program.

The manual is organized so that all the information on a particular system is kept together. The order of grouping is as follows:

- Table of Contents
- General Diagnostic Information
- Specifications
- Electrical Wiring Harness Legend
- Component Location
- System Schematic
- Electrical Wiring Harness
- Troubleshooting Chart
- Theory of Operation
- Diagnostics
- Tests & Adjustments
- Repair

Note: Depending on the particular section or system being covered, not all of the above groups may be used.

Each section will be identified with a symbol rather than a number. The groups and pages within a section will be consecutively numbered.

We appreciate your input on this manual. To help, there are postage paid post cards included at the back. If you find any errors or want to comment on the layout of the manual please fill out one of the cards and mail it back to us.

All information, illustrations, and specifications in this manual are based on the latest information available at the time of publication. The right is reserved to make changes at any time without notice.

COPYRIGHT® 1997
Deere & Co.
John Deere Worldwide Commercial and
Consumer Equipment Division
Horicon, WI

All rights reserved

Previous Editions
COPYRIGHT® 1996, 1997

Safety



Specifications and Information



Kawasaki Engines



Kohler Engine



Electrical



Gear Power Train



Hydrostatic Power Train



Attachments



Miscellaneous





RECOGNIZE SAFETY INFORMATION



This is the safety-alert symbol. When you see this symbol on your machine or in this manual, be alert to the potential for personal injury.

Follow recommended precautions and safe servicing practices.

Understand Signal Words

A signal word—DANGER, WARNING, or CAUTION—is used with the safety-alert symbol. DANGER identifies the most serious hazards.

DANGER or WARNING safety signs are located near specific hazards. General precautions are listed on CAUTION safety signs. CAUTION also calls attention to safety messages in this manual.

REPLACE SAFETY SIGNS



Replace missing or damaged safety signs. See the machine operator's manual for correct safety sign placement.

HANDLE FLUIDS SAFELY-AVOID FIRES

Be Prepared For Emergencies

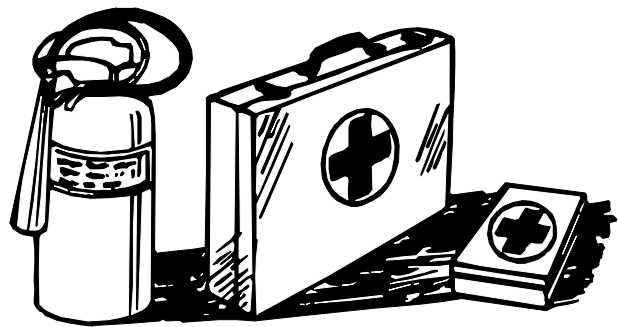

When you work around fuel, do not smoke or work near heaters or other fire hazards.

Store flammable fluids away from fire hazards. Do not incinerate or puncture pressurized containers.

Make sure machine is clean of trash, grease, and debris.

Do not store oily rags; they can ignite and burn spontaneously.

Be prepared if a fire starts.

Keep a first aid kit and fire extinguisher handy.

Keep emergency numbers for doctors, ambulance service, hospital, and fire department near your telephone.

USE CARE IN HANDLING AND SERVICING BATTERIES

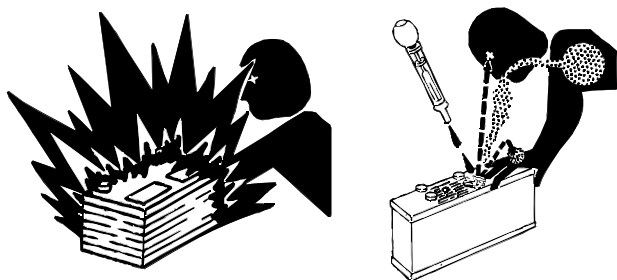

Prevent Battery Explosions

- Keep sparks, lighted matches, and open flame away from the top of battery. Battery gas can explode.
- Never check battery charge by placing a metal object across the posts. Use a volt-meter or hydrometer.
- Do not charge a frozen battery; it may explode. Warm battery to 16°C (60°F).

Prevent Acid Burns

- Sulfuric acid in battery electrolyte is poisonous. It is strong enough to burn skin, eat holes in clothing, and cause blindness if splashed into eyes.
- **Avoid acid burns by:**
 1. Filling batteries in a well-ventilated area.
 1. Wearing eye protection and rubber gloves.
 1. Avoiding breathing fumes when electrolyte is added.
 1. Avoiding spilling or dripping electrolyte.
 1. Use proper jump start procedure.
- **If you spill acid on yourself:**
 1. Flush your skin with water.
 1. Apply baking soda or lime to help neutralize the acid.
 1. Flush your eyes with water for 10_15 minutes.
 1. Get medical attention immediately.
- **If acid is swallowed:**
 1. Drink large amounts of water or milk.
 1. Then drink milk of magnesia, beaten eggs, or vegetable oil.
 1. Get medical attention immediately.

USE CARE AROUND HIGH-PRESSURE FLUID LINES

Avoid High-pressure Fluids

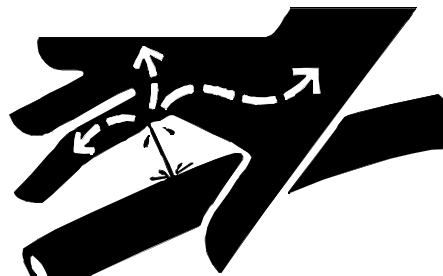

Escaping fluid under pressure can penetrate the skin causing serious injury.

Avoid injury from escaping fluid under pressure by stopping the engine and relieving pressure in the system before disconnecting or connecting hydraulic or other lines. Tighten all connections before applying pressure.

Search for leaks with a piece of cardboard. Protect hands and body from high pressure fluids.

If an accident occurs, see a doctor immediately. Any fluid injected into the skin must be surgically removed within a few hours or gangrene may result. Doctors unfamiliar with this type of injury should reference a knowledgeable medical source. Such information is available from Deere & Company Medical Department in Moline, Illinois, U.S.A.

Avoid Heating Near Pressurized Fluid Lines



Flammable spray can be generated by heating near pressurized fluid lines, resulting in severe burns to yourself and bystanders. Do not heat by welding, soldering, or using a torch near pressurized fluid lines or other flammable materials. Pressurized lines can be accidentally cut when heat goes beyond the immediate flame area.



**Thanks very much for your reading,
Want to get more information,
Please click here, Then get the complete
manual**

JustClickHere 

NOTE:

**If there is no response to click on the link above,
please download the PDF document first, and then
click on it.**

**Have any questions please write to me:
admin@servicemanualperfect.com**



USE SAFE SERVICE PROCEDURES

Wear Protective Clothing

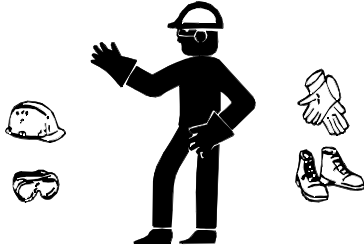

Wear close fitting clothing and safety equipment appropriate to the job.

Prolonged exposure to loud noise can cause impairment or loss of hearing. Wear a suitable hearing protective device such as earmuffs or earplugs to protect against objectionable or uncomfortable loud noises.

Operating equipment safely requires the full attention of the operator. Do not wear radio or music headphones while operating machine.

Service Machines Safely

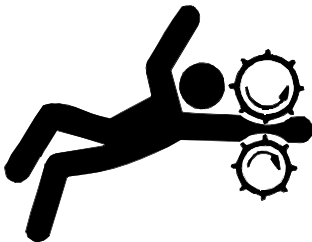

Tie long hair behind your head. Do not wear a necktie, scarf, loose clothing, or necklace when you work near machine tools or moving parts. If these items were to get caught, severe injury could result.

Remove rings and other jewelry to prevent electrical shorts and entanglement in moving parts.

Use Proper Tools

Use tools appropriate to the work. Makeshift tools and procedures can create safety hazards. Use power tools only to loosen threaded parts and fasteners. For loosening and tightening hardware, use the correct size tools. **DO NOT** use U.S. measurement tools on metric fasteners. Avoid bodily injury caused by slipping wrenches. Use only service parts meeting John Deere specifications.

Park Machine Safely

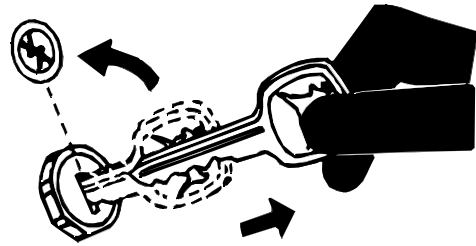

Before working on the machine:

1. Lower all equipment to the ground.
1. Stop the engine and remove the key.
1. Disconnect the battery ground strap.
1. Hang a "DO NOT OPERATE" tag in operator station.

Support Machine Properly And Use Proper Lifting Equipment

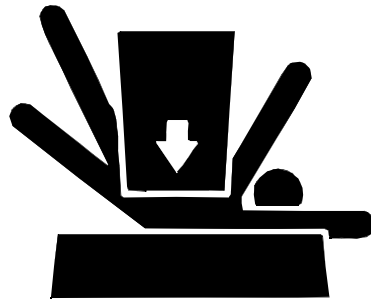

If you must work on a lifted machine or attachment, securely support the machine or attachment.

Do not support the machine on cinder blocks, hollow tiles, or props that may crumble under continuous load. Do not work under a machine that is supported solely by a jack. Follow recommended procedures in this manual.

Lifting heavy components incorrectly can cause severe injury or machine damage. Follow recommended procedure for removal and installation of components in the manual.

Work In Clean Area

Before starting a job:

1. Clean work area and machine.
1. Make sure you have all necessary tools to do your job.
1. Have the right parts on hand.
1. Read all instructions thoroughly; do not attempt shortcuts.

Using High Pressure Washers

Directing pressurized water at electronic/electrical components or connectors, bearings, hydraulic seals, fuel injection pumps or other sensitive parts and components may cause product malfunctions. Reduce pressure and spray at a 45 to 90 degree angle.

Illuminate Work Area Safely

Illuminate your work area adequately but safely. Use a portable safety light for working inside or under the machine. Make sure the bulb is enclosed by a wire cage. The hot filament of an accidentally broken bulb can ignite spilled fuel or oil.

Work In Ventilated Area

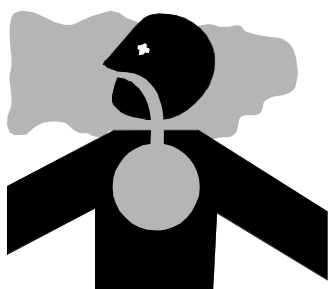

Engine exhaust fumes can cause sickness or death. If it is necessary to run an engine in an enclosed area, remove the exhaust fumes from the area with an exhaust pipe extension.

If you do not have an exhaust pipe extension, open the doors and get outside air into the area.

WARNING: California Proposition 65 Warning

Diesel engine exhaust and some of its constituents are known to the State of California to cause cancer, birth defects, and other reproductive harm.

Gasoline engine exhaust from this product contains chemicals known to the State of California to cause cancer, birth defects, or other reproductive harm.

Remove Paint Before Welding Or Heating

Avoid potentially toxic fumes and dust. Hazardous fumes can be generated when paint is heated by welding, soldering, or using a torch. Do all work outside or in a well ventilated area. Dispose of paint and solvent properly. Remove paint before welding or heating: If you sand or grind paint, avoid breathing the dust. Wear an approved respirator. If you use solvent or paint stripper, remove stripper with soap and water before welding. Remove solvent or paint stripper containers and other flammable material from area. Allow fumes to disperse at least 15 minutes before welding or heating.

Avoid Harmful Asbestos Dust

Avoid breathing dust that may be generated when handling components containing asbestos fibers. Inhaled asbestos fibers may cause lung cancer.

Components in products that may contain asbestos fibers are brake pads, brake band and lining assemblies, clutch plates, and some gaskets. The asbestos used in these components is usually found in a resin or sealed in some way. Normal handling is not hazardous as long as airborne dust containing asbestos is not generated.

Avoid creating dust. Never use compressed air for cleaning. Avoid brushing or grinding material containing asbestos. When servicing, wear an approved respirator. A special vacuum cleaner is recommended to clean asbestos. If not available, apply a mist of oil or water on the material containing asbestos. Keep bystanders away from the area.



SERVICE TIRES SAFELY



Explosive separation of a tire and rim parts can cause serious injury or death.

Do not attempt to mount a tire unless you have the proper equipment and experience to perform the job. Always maintain the correct tire pressure. Do not inflate the tires above the recommended pressure. Never weld or heat a wheel and tire assembly. The heat can cause an increase in air pressure resulting in a tire explosion. Welding can structurally weaken or deform the wheel.

When inflating tires, use a clip-on chuck and extension hose long enough to allow you to stand to one side and NOT in front of or over the tire assembly. Use a safety cage if available.

Check wheels for low pressure, cuts, bubbles, damaged rims or missing lug bolts and nuts.

SAFETY



AVOID INJURY FROM ROTATING BLADES, AUGERS AND PTO SHAFTS

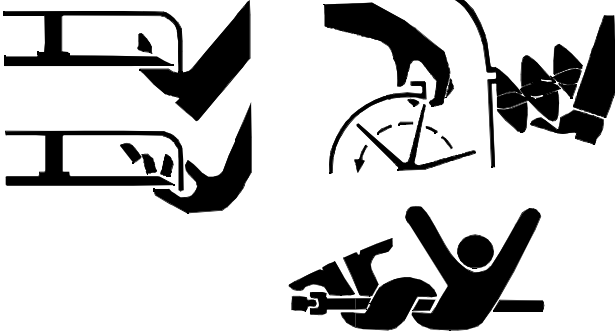

Keep hands and feet away while machine is running. Shut off power to service, lubricate or remove mower blades, augers or PTO shafts.

SERVICE COOLING SYSTEM SAFELY



Explosive release of fluids from pressurized cooling system can cause serious burns.

Shut off machine. Only remove filler cap when cool enough to touch with bare hands. Slowly loosen cap to first stop to relieve pressure before removing completely.

HANDLE CHEMICAL PRODUCTS SAFELY

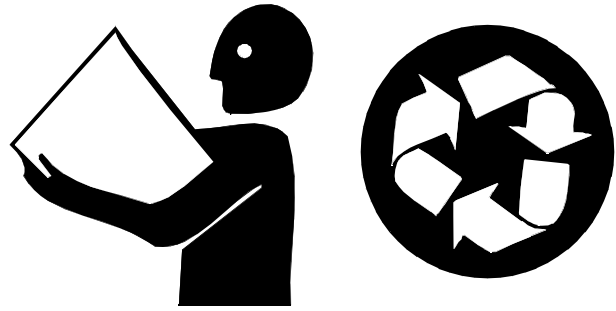

Direct exposure to hazardous chemicals can cause serious injury. Potentially hazardous chemicals used with John Deere equipment include such items as lubricants, coolants, paints, and adhesives.

A Material Safety Data Sheet (MSDS) provides specific details on chemical products: physical and health hazards, safety procedures, and emergency response techniques. Check the MSDS before you start any job using a hazardous chemical. That way you will know exactly what the risks are and how to do the job safely. Then follow procedures and recommended equipment.

Dispose of Waste Properly

Improperly disposing of waste can threaten the environment and ecology. Potentially harmful waste used with John Deere equipment include such items as oil, fuel, coolant, brake fluid, filters, and batteries. Use leakproof containers when draining fluids. Do not use food or beverage containers that may mislead someone into drinking from them. Do not pour waste onto the ground, down a drain, or into any water source. Inquire on the proper way to recycle or dispose of waste from your local environmental or recycling center, or from your John Deere dealer.

LIVE WITH SAFETY



Before returning machine to customer, make sure machine is functioning properly, especially the safety systems. Install all guards and shields.

CONTENTS

Page



SPECIFICATIONS & INFORMATION

SPECIFICATIONS

| | |
|-------------------------------|---|
| ENGINE | 2 |
| POWER TRAIN—GEAR | 2 |
| POWER TRAIN—HYDROSTATIC | 3 |
| MOWER DECKS | 3 |
| GENERAL | 3 |
| DIMENSIONS | 3 |

| | |
|--|----------|
| METRIC FASTENER TORQUE VALUES | 4 |
|--|----------|

| | |
|--|----------|
| INCH FASTENER TORQUE VALUES | 5 |
|--|----------|

GASOLINE

| | |
|---|----|
| GASOLINE—NORTH AMERICA | 6 |
| GASOLINE STORAGE | 6 |
| GASOLINE—EUROPE | 7 |
| ENGINE OIL—NORTH AMERICA | 8 |
| ENGINE OIL—EUROPE | 8 |
| BREAK-IN ENGINE OIL—NORTH AMERICA | 9 |
| BREAK-IN ENGINE OIL—EUROPE | 9 |
| TRANSMISSION GREASE—GEAR | 10 |
| HYDROSTATIC TRANSAXLE OIL—NORTH AMERICA | 10 |
| HYDROSTATIC TRANSAXLE OIL—EUROPE | 11 |
| ANTI-CORROSION GREASE SPECIFICATIONS | 11 |
| ALTERNATIVE LUBRICANTS | 12 |
| SYNTHETIC LUBRICANTS | 12 |
| LUBRICANT STORAGE | 12 |
| MIXING OF LUBRICANTS | 12 |
| OIL FILTERS | 12 |

IDENTIFICATION

| | |
|--|----|
| SERIAL NUMBER INFORMATION | 13 |
| PRODUCT IDENTIFICATION NUMBER LOCATION | 13 |
| ENGINE SERIAL NUMBER LOCATION - KAWASAKI ENGINES | 13 |
| ENGINE SERIAL NUMBER LOCATION - KOHLER ENGINE | 13 |
| GEAR TRANSMISSION SERIAL NUMBER LOCATION | 13 |
| HYDROSTATIC TRANSAXLE SERIAL NUMBER LOCATION | 14 |
| MOWER DECK SERIAL NUMBER LOCATION—36 INCH | 14 |
| MOWER DECK SERIAL NUMBER LOCATION—48/54 INCH | 14 |

SPECIFICATIONS

ENGINE



| | GS25 | GS30 | GS45, HD45 | GS75, HD75 |
|--|--------------------------------------|--------------------------------------|--------------------------------------|--------------------------------------|
| Horsepower | 9.3 Kw (12.5 hp) | 9.7 Kw (13 hp) | 10.5 Kw (14 hp) | 12.7 Kw (17 hp) |
| Model number | FC401V-BS05 | CV13S | FC420V-AS19 | FC540V-AS17 |
| Manufacturer | Kawasaki | Kohler | Kawasaki | Kawasaki |
| Displacement | 423 cc (25.8 cu. in.) | 398 cc (24.3 cu. in.) | 423 cc (25.8 cu. in.) | 535 cc (32.6 cu. in.) |
| No. of cylinders | One | One | One | One |
| Fast idle speed | 3350 ± 100 rpm | 3350 ± 100 rpm | 3350 ± 100 rpm | 3350 ± 100 rpm |
| Slow idle speed | 1450 ± 75 rpm | 1550 ± 75 rpm | 1450 ± 75 rpm | 1450 ± 75 rpm |
| Ignition | Solid state electronic | Solid state electronic | Solid state electronic | Solid state electronic |
| Crankcase capacity without oil filter | 1.3 L (2.8 U.S. pt.) | 1.9 L (4 U.S. pt.) | 1.3 L (2.8 U.S. pt.) | 1.6 L (3.4 U.S. pt.) |
| Crankcase capacity with oil filter | 1.5 L (3.17 U.S. pt.) | | 1.6 L (3.4 U.S. pt.) | 1.9 L (4.0 U.S. pt.) |
| Oil filter | Standard | Standard | Standard | Standard |
| Type of fuel | Regular grade leaded or lead-free | Regular grade leaded or lead-free | Regular grade leaded or lead-free | Regular grade leaded or lead-free |
| Air cleaner | Dual stage | Dual stage | Dual stage | Dual stage |
| Governor | Mechanical | Mechanical | Mechanical | Mechanical |
| Fuel tank capacity | 19 L (5.0 U.S. gal.) | 19 L (5.0 U.S. gal.) | 19 L (5.0 U.S. gal.) | 19 L (5.0 U.S. gal.) |

POWER TRAIN—GEAR

| | GS25 | GS30 | GS45 | GS75 |
|---------------------|--|-------------------------------------|-------------------------------------|-------------------------------------|
| Transmission | Dana, 5-speed with reverse | Dana, 5-speed with reverse | Dana, 5-speed with reverse | Dana, 5-speed with reverse |
| Shift mechanism | Enclosed gear with keys | Enclosed gear with keys | Enclosed gear with keys | Enclosed gear with keys |
| Brakes | Band | Band | Band | Band |
| Axle | Solid axle, 25 mm (1 in.) diameter, with grease lubricated roller bearings in wheels | | | |
| Drive wheels | 330 x 165 mm (13 x 6.5 in.) | 330 x 165 mm (13 x 6.5 in.) | 330 x 165 mm (13 x 6.5 in.) | 330 x 165 mm (13 x 6.5 in.) |
| Ground speeds: | | | | |
| Forward speeds | 5 | 5 | 5 | 5 |
| Reverse Speeds | 1 | 1 | 1 | 1 |
| Forward Speed range | 2.9 to 9.6 km/h (1.8 to 5.9 mph) | 2.9 to 9.6 km/h (1.8 to 5.9 mph) | 2.9 to 9.6 km/h (1.8 to 5.9 mph) | 2.9 to 9.6 km/h (1.8 to 5.9 mph) |
| Reverse Speed Range | 1.2 km/h (0.75 mph) | 1.2 km/h (0.75 mph) | 1.2 km/h (0.75 mph) | 1.2 km/h (0.75 mph) |

POWER TRAIN—HYDROSTATIC

| | HD45 | HD75 |
|---------------------|--|--------------------------------|
| Transmission | Eaton 778 | Eaton 778 |
| Shift mechanism | Unitized, Infinitely variable, dual hydrostatic transaxles with reverse, and brakes. | |
| Brakes | Hydrostatic lever for forward, individual turn levers for right, left, and reverse. | |
| Axle | Internal wet disk | Internal wet disk |
| Drive wheels | Individual left and right side axles with wheel flanges, roller bearings mounted inside transaxle and splash lubricated. | |
| Forward Speed range | 406 x 165 mm (16 x 6.5 in.) | 406 x 165 mm (16 x 6.5 in.) |
| Reverse Speed Range | 0 to 8.1 km/h (0 to 6 mph) | 0 to 8.1 km/h (0 to 6 mph) |
| | 0 to 1.6 km/h (0 to 1 mph) | 0 to 1.6 km/h (0 to 1 mph) |



MOWER DECKS

| | 914 mm (36 in.) | 914 mm (36 in.) | 1219 mm (48 in.) | 1372 mm (54 in.) |
|--------------------------|--------------------------------|--------------------------------|-----------------------------------|-----------------------------------|
| Deck material | 10-gauge steel, fabricated | 10-gauge steel, fabricated | 11-gauge steel, one-piece stamped | 11-gauge steel, one-piece stamped |
| Blades | Two, 472 mm (18.6 in.) | Two, 472 mm (18.6 in.) | Three, 422 mm (16.6 in.) | Three, 472 mm (18.6 in.) |
| Blade drive | V-belt and timed cogged belt | V-belt and timed cogged belt | V-belt with self-adjusting idler | V-belt with self-adjusting idler |
| Cutting heights | 19 to 114 mm (3/4 to 4-1/2in.) | 19 to 114 mm (3/4 to 4-1/2in.) | 25 to 127 mm (1 to 5 in.) | 25 to 127 mm (1 to 5 in.) |
| Weight (Mower deck only) | 83.9 Kg (185 lb) | 83.9 Kg (185 lb) | 83.5 Kg (184 lb) | 87.4 Kg (193 lb) |

GENERAL

| | | | | |
|---------------|---------------------------|---------------------------|---------------------------|---------------------------|
| Caster wheels | 228 x 89 mm (9 x 3.5 in.) | 228 x 89 mm (9 x 3.5 in.) | 228 x 89 mm (9 x 3.5 in.) | 228 x 89 mm (9 x 3.5 in.) |
|---------------|---------------------------|---------------------------|---------------------------|---------------------------|

DIMENSIONS

| | GS25 | GS30 | GS45 | GS75 |
|-------------------------------------|-------------------|-------------------|--------------------|--------------------|
| Overall height | 1041 mm (41 in.) | 1041 mm (41 in.) | 1041 mm (41 in.) | 1041 mm (41 in.) |
| Overall length | 2032 mm (80 in.) | 2032 mm (80 in.) | 2032 mm (80 in.) | 2032 mm (80 in.) |
| Overall width | 927 mm (36.5 in.) | 927 mm (36.5 in.) | 1308 mm (51.5 in.) | 1460 mm (57.5 in.) |
| Traction Unit Weight (Without deck) | | 124.7 Kg (275 lb) | 124.7 Kg (275 lb) | 136.8 Kg (302 lb) |
| | HD45 | HD75 | | |
| Overall height | 1118 mm (44 in.) | 1118 mm (44 in.) | | |
| Overall length | 1981 mm (78 in.) | 1981 mm (78 in.) | | |
| Traction Unit Weight (Without deck) | 146.1 Kg (322 lb) | 162.5 Kg (358 lb) | | |

METRIC FASTENER TORQUE VALUES

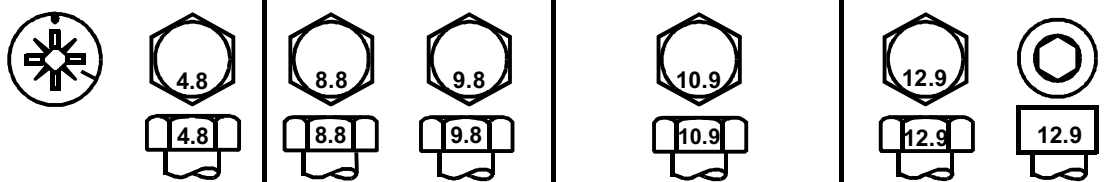
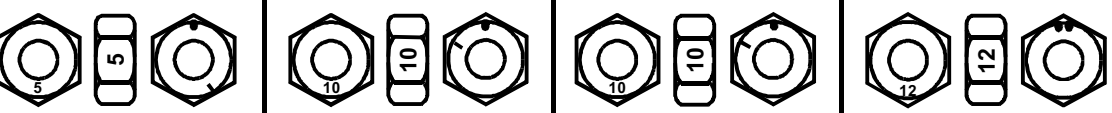
| | |
|---|--|
|  | <p>Property Class and Head Markings</p>  |
| | <p>Property Class and Nut Markings</p>  |

TS1163

| SIZE | Class 4.8 | | | | Class 8.8 or 9.8 | | | | Class 10.9 | | | | Class 12.9 | | | |
|------|-------------------------|-------|------------------|-------|-------------------------|-------|------------------|-------|-------------------------|-------|------------------|-------|-------------------------|-------|------------------|-------|
| | Lubricated ^a | | Dry ^a | | Lubricated ^a | | Dry ^a | | Lubricated ^a | | Dry ^a | | Lubricated ^a | | Dry ^a | |
| | N•m | lb-ft | N•m | lb-ft | N•m | lb-ft | N•m | lb-ft | N•m | lb-ft | N•m | lb-ft | N•m | lb-ft | N•m | lb-ft |
| M6 | 48 | 3.5 | 6 | 4.5 | 9 | 6.5 | 11 | 8.5 | 13 | 9.5 | 17 | 12 | 15 | 11.5 | 19 | 14.5 |
| M8 | 12 | 8.5 | 15 | 11 | 22 | 16 | 28 | 20 | 32 | 24 | 40 | 30 | 37 | 28 | 47 | 35 |
| M10 | 23 | 17 | 29 | 21 | 43 | 32 | 55 | 40 | 63 | 47 | 80 | 60 | 75 | 55 | 95 | 70 |
| M12 | 40 | 29 | 50 | 37 | 75 | 55 | 95 | 70 | 110 | 80 | 140 | 105 | 130 | 95 | 165 | 120 |
| M14 | 63 | 47 | 80 | 60 | 120 | 88 | 150 | 110 | 175 | 130 | 225 | 165 | 205 | 150 | 260 | 109 |
| M16 | 100 | 73 | 125 | 92 | 190 | 140 | 240 | 175 | 275 | 200 | 350 | 225 | 320 | 240 | 400 | 300 |
| M18 | 135 | 100 | 175 | 125 | 260 | 195 | 330 | 250 | 375 | 275 | 475 | 350 | 440 | 325 | 560 | 410 |
| M20 | 190 | 140 | 240 | 180 | 375 | 275 | 475 | 350 | 530 | 400 | 675 | 500 | 625 | 460 | 800 | 580 |
| M22 | 260 | 190 | 330 | 250 | 510 | 375 | 650 | 475 | 725 | 540 | 925 | 675 | 850 | 625 | 1075 | 800 |
| M24 | 330 | 250 | 425 | 310 | 650 | 475 | 825 | 600 | 925 | 675 | 1150 | 850 | 1075 | 800 | 1350 | 1000 |
| M27 | 490 | 360 | 625 | 450 | 950 | 700 | 1200 | 875 | 1350 | 1000 | 1700 | 1250 | 1600 | 1150 | 2000 | 1500 |
| M30 | 675 | 490 | 850 | 625 | 1300 | 950 | 1650 | 1200 | 1850 | 1350 | 2300 | 1700 | 2150 | 1600 | 2700 | 2000 |
| M33 | 900 | 675 | 1150 | 850 | 1750 | 1300 | 2200 | 1650 | 2500 | 1850 | 3150 | 2350 | 2900 | 2150 | 3700 | 2750 |
| M36 | 1150 | 850 | 1450 | 1075 | 2250 | 1650 | 2850 | 2100 | 3200 | 2350 | 4050 | 3000 | 3750 | 2750 | 4750 | 3500 |

DO NOT use these hand torque values if a different torque value or tightening procedure is given for a specific application. Torque values listed are for general use only and include a ±10% variance factor. Check tightness of fasteners periodically. DO NOT use air powered wrenches.

Shear bolts are designed to fail under predetermined loads. Always replace shear bolts with identical grade.

Fasteners should be replaced with the same grade. Make sure fastener threads are clean and that you properly start thread engagement. This will prevent them from failing when tightening.









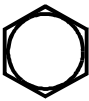

When bolt and nut combination fasteners are used, torque values should be applied to the **NUT** instead of the bolt head.

Tighten toothed or serrated-type lock nuts to the full torque value.

^a "Lubricated" means coated with a lubricant such as engine oil, or fasteners with phosphate and oil coatings. "Dry" means plain or zinc plated (yellow dichromate - Specification JDS117) without any lubrication.

Reference: JDS—G200.

INCH FASTENER TORQUE VALUES

| | | | |
|-----------------------------|---|--|---|
| SAE Grade and Head Markings | 1 or 2 ^b No Marks  | 5  5.1  5.2  | 8  8.2  |
| | 2 No Marks  | 5   | 8   |

TS1162



| SIZE | Grade 1 | | Grade 2 ^b | | | | Grade 5, 5.1 or 5.2 | | | | Grade 8 or 8.2 | | | | | |
|-------|-------------------------|-------|----------------------|-------|-------------------------|-------|---------------------|-------|-------------------------|-------|------------------|-------|-------------------------|-------|------------------|-------|
| | Lubricated ^a | | Dry ^a | | Lubricated ^a | | Dry ^a | | Lubricated ^a | | Dry ^a | | Lubricated ^a | | Dry ^a | |
| | N•m | lb-ft | N•m | lb-ft | N•m | lb-ft | N•m | lb-ft | N•m | lb-ft | N•m | lb-ft | N•m | lb-ft | N•m | lb-ft |
| 1/4 | 3.7 | 2.8 | 4.7 | 3.5 | 6 | 4.5 | 7.5 | 5.5 | 9.5 | 7 | 12 | 9 | 13.5 | 10 | 17 | 12.5 |
| 5/16 | 7.7 | 5.5 | 10 | 7 | 12 | 9 | 15 | 11 | 20 | 15 | 25 | 18 | 28 | 21 | 35 | 26 |
| 3/8 | 14 | 10 | 17 | 13 | 22 | 16 | 27 | 20 | 35 | 26 | 44 | 33 | 50 | 36 | 63 | 46 |
| 7/16 | 22 | 16 | 28 | 20 | 35 | 26 | 44 | 32 | 55 | 41 | 70 | 52 | 80 | 58 | 100 | 75 |
| 1/2 | 33 | 25 | 42 | 31 | 53 | 39 | 67 | 50 | 85 | 63 | 110 | 80 | 120 | 90 | 150 | 115 |
| 9/16 | 48 | 36 | 60 | 45 | 75 | 56 | 95 | 70 | 125 | 90 | 155 | 115 | 175 | 130 | 225 | 160 |
| 5/8 | 67 | 50 | 85 | 62 | 105 | 78 | 135 | 100 | 170 | 125 | 215 | 160 | 215 | 160 | 300 | 225 |
| 3/4 | 120 | 87 | 150 | 110 | 190 | 140 | 240 | 175 | 300 | 225 | 375 | 280 | 425 | 310 | 550 | 400 |
| 7/8 | 190 | 140 | 240 | 175 | 190 | 140 | 240 | 175 | 490 | 360 | 625 | 450 | 700 | 500 | 875 | 650 |
| 1 | 290 | 210 | 360 | 270 | 290 | 210 | 360 | 270 | 725 | 540 | 925 | 675 | 1050 | 750 | 1300 | 975 |
| 1-1/8 | 470 | 300 | 510 | 375 | 470 | 300 | 510 | 375 | 900 | 675 | 1150 | 850 | 1450 | 1075 | 1850 | 1350 |
| 1-1/4 | 570 | 425 | 725 | 530 | 570 | 425 | 725 | 530 | 1300 | 950 | 1650 | 1200 | 2050 | 1500 | 2600 | 1950 |
| 1-3/8 | 750 | 550 | 950 | 700 | 750 | 550 | 950 | 700 | 1700 | 1250 | 2150 | 1550 | 2700 | 2000 | 3400 | 2550 |
| 1-1/2 | 1000 | 725 | 1250 | 925 | 990 | 725 | 1250 | 930 | 2250 | 1650 | 2850 | 2100 | 3600 | 2650 | 4550 | 3350 |

DO NOT use these hand torque values if a different torque value or tightening procedure is given for a specific application. Torque values listed are for general use only and include a ±10% variance factor. Check tightness of fasteners periodically. DO NOT use air powered wrenches.

Shear bolts are designed to fail under predetermined loads. Always replace shear bolts with identical grade.

Fasteners should be replaced with the same grade. Make sure fastener threads are clean and that you properly start thread engagement. This will prevent them from failing when tightening.

When bolt and nut combination fasteners are used, torque values should be applied to the **NUT** instead of the bolt head.

Tighten toothed or serrated-type lock nuts to the full torque value.

^a "Lubricated" means coated with a lubricant such as engine oil, or fasteners with phosphate and oil coatings. "Dry" means plain or zinc plated (yellow dichromate - Specification JDS117) without any lubrication.

^b "Grade 2" applies for hex cap screws (not hex bolts) up to 152 mm (6-in.) long. "Grade 1" applies for hex cap screws over 152 mm (6-in.) long, and for all other types of bolts and screws of any length.

GASOLINE—NORTH AMERICA

 **CAUTION**

Gasoline is **HIGHLY FLAMMABLE**, handle it with care.

DO NOT refuel machine while:

- indoors, always fill gas tank outdoors;
- machine is near an open flame or sparks;
- engine is running, **STOP** engine;
- engine is hot, allow it to cool sufficiently first;
- smoking.

Help prevent fires:

- fill gas tank to bottom of filler neck only;
- be sure fill cap is tight after fueling;
- clean up any gas spills **IMMEDIATELY**;
- keep machine clean and in good repair—free of excess grease, oil, debris, and faulty or damaged parts;
- any storage of machines with gas left in tank should be in an area that is well ventilated to prevent possible igniting of fumes by an open flame or spark, this includes any appliance with a pilot light.

To prevent fire or explosion caused by STATIC ELECTRIC DISCHARGE during fueling:

- **ONLY** use a clean, approved **POLYETHYLENE PLASTIC** fuel container and funnel **WITHOUT** any metal screen or filter.

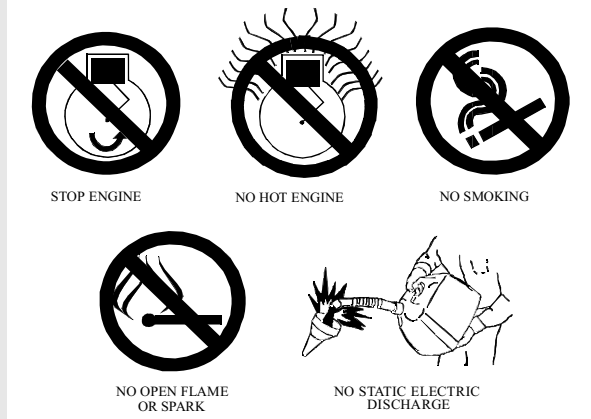

To avoid engine damage:

- DO NOT mix oil with gasoline;
- **ONLY** use clean, fresh unleaded gasoline with an octane rating (anti-knock index) of 87 or higher;
- fill gas tank at the end of each day's operation to help prevent condensation from forming inside a partially filled tank;
- keep up with specified service intervals.

Use of alternative oxygenated, gasohol blended, unleaded gasoline is acceptable as long as:

- the ethyl or grain alcohol blends DO NOT exceed 10% by volume or
- methyl tertiary butyl ether (MTBE) blends DO NOT exceed 15% by volume.

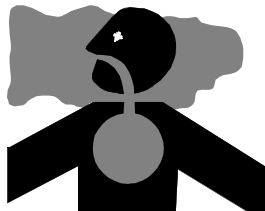

IMPORTANT: DO NOT use **METHANOL** gasolines because **METHANOL** is harmful to the environment and to your health.

 **WARNING**

California Proposition 65 Warning: Gasoline engine exhaust from this product contains chemicals known to the State of California to cause cancer, birth defects, or other reproductive harm.

GASOLINE STORAGE

IMPORTANT: Keep all dirt, scale, water or other foreign material out of gasoline.

Keep gasoline stored in a safe, protected area. Storage of gasoline in a clean, properly marked ("**UNLEADED GASOLINE**") **POLYETHYLENE PLASTIC** container **WITHOUT** any metal screen or filter is recommended. **DO NOT** use de-icers to attempt to remove water from gasoline or depend on fuel filters to remove water from gasoline. Use a water separator installed in the storage tank outlet. **BE SURE** to properly discard unstable or contaminated gasoline. When storing unit or gasoline, equivalent to the gasoline. **BE SURE** to follow directions on container and to properly discard empty container.

GASOLINE—EUROPE

⚠ CAUTION

Gasoline is **HIGHLY FLAMMABLE**, handle it with care.

DO NOT refuel machine while:

- indoors, always fill gas tank outdoors;
- machine is near an open flame or sparks;
- engine is running, **STOP** engine;
- engine is hot, allow it to cool sufficiently first;
- smoking.

Help prevent fires:

- fill gas tank to bottom of filler neck only;
- be sure fill cap is tight after fueling;
- clean up any gas spills **IMMEDIATELY**;
- keep machine clean and in good repair—free of excess grease, oil, debris, and faulty or damaged parts;
- any storage of machines with gas left in tank should be in an area that is well ventilated to prevent possible igniting of fumes by an open flame or spark, this includes any appliance with a pilot light.

To prevent fire or explosion caused by STATIC ELECTRIC DISCHARGE during fueling:

- **ONLY** use a clean, approved **POLYETHYLENE PLASTIC** fuel container and funnel **WITHOUT** any metal screen or filter.

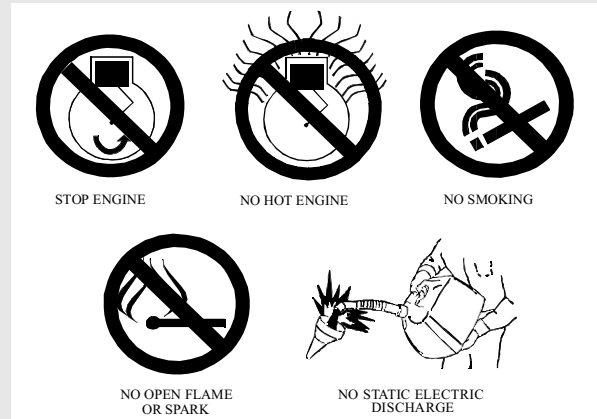

To avoid engine damage:

- DO NOT mix oil with gasoline;
- **ONLY** use clean, fresh unleaded gasoline with an octane rating (anti-knock index) of 87 or higher;
- fill gas tank at the end of each day's operation to help prevent condensation from forming inside a partially filled tank;
- keep up with specified service intervals.

Use of alternative oxygenated, gasohol blended, unleaded gasoline is acceptable as long as:

- the ethyl or grain alcohol blends DO NOT exceed 10% by volume or
- methyl tertiary butyl ether (MTBE) blends DO NOT exceed 15% by volume.

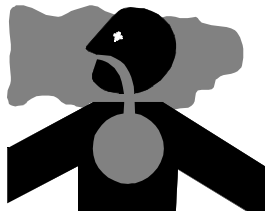

IMPORTANT: DO NOT use **METHANOL** gasolines because **METHANOL** is harmful to the environment and to your health.

ENGINE OIL—NORTH AMERICA

Use the appropriate oil viscosity based on the expected air temperature range during the period between recommended oil changes. Operating outside of these recommended oil air temperature ranges may cause premature engine failure.

The following John Deere oils are **PREFERRED**:

- **PLUS-4®—SAE 10W-40;**
- **TORQ-GARD SUPREME®—SAE 5W-30.**

The following John Deere oils are **also recommended**, based on their specified temperature range:

- **TURF-GARD®—SAE 10W-30;**
- **PLUS-4®—SAE 10W-30;**
- **TORQ-GARD SUPREME®—SAE 30.**

Other oils may be used if above John Deere oils are not available, provided they meet one of the following specifications:

- SAE 10W-40—API Service Classification SG or higher;
- SAE 5W-30—API Service Classification SG or higher;
- SAE 10W-30—API Service Classification SG or higher;
- SAE 30—API Service Classification SC or higher.

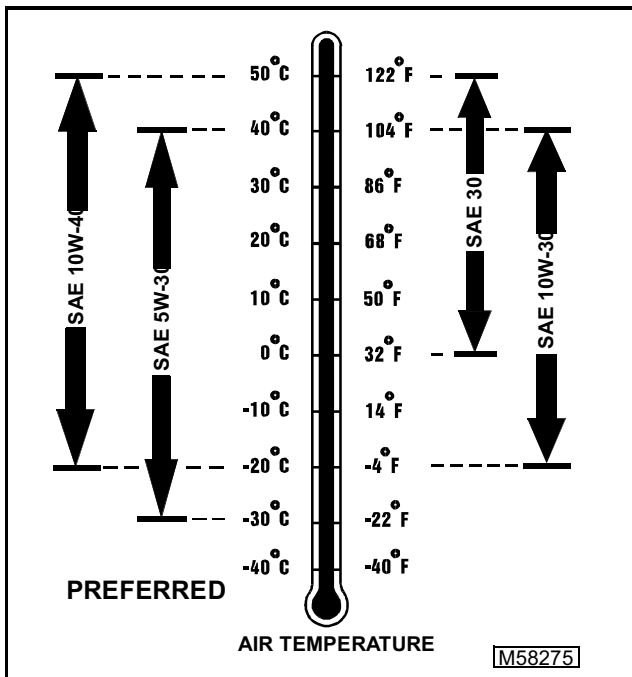

John Deere Dealers: You may want to cross-reference the following publications to recommend the proper oil for your customers:

- Module DX, ENOIL2 in JDS-G135;
- Section 530, Lubricants & Hydraulics, of the John Deere Merchandise Sales Guide;
- Lubrication Sales Manual PI7032.

ENGINE OIL—EUROPE

Use the appropriate oil viscosity based on the expected air temperature range during the period between recommended oil changes. Operating outside of these recommended oil air temperature ranges may cause premature engine failure.

The following John Deere oils are **PREFERRED**:

- **TORQ-GARD SUPREME®—SAE 10W-40;**
- **UNI-GARD™—SAE 10W-40;**
- **TORQ-GARD SUPREME®—SAE 5W-30;**
- **UNI-GARD™—SAE 5W-30.**

The following John Deere oils are **also recommended**, based on their specified temperature range:

- **TORQ-GARD SUPREME®—SAE 10W-30;**
- **UNI-GARD™—SAE 10W-30;**
- **TORQ-GARD SUPREME®—SAE 30;**
- **UNI-GARD™—SAE 30.**

Other oils may be used if above John Deere oils are not available, provided they meet one of the following specifications:

- CCMC Specification G4 or higher.

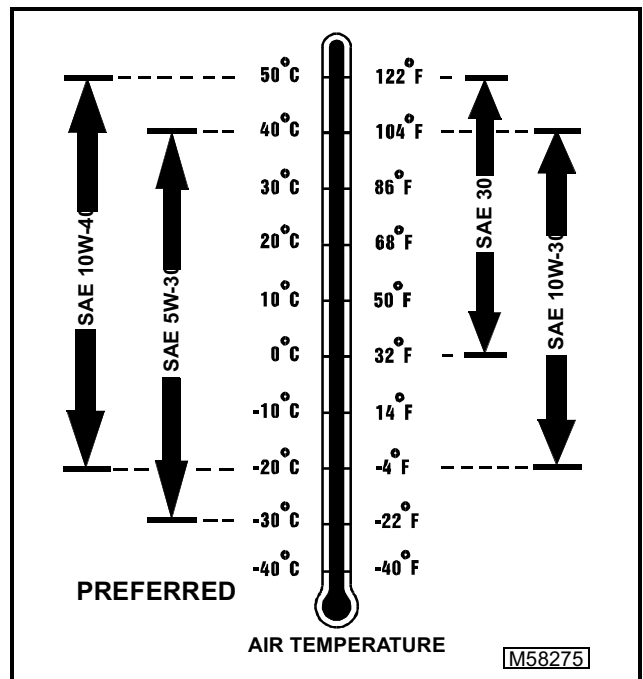

John Deere Dealers: You may want to cross-reference the following publications to recommend the proper oil for your customers:

- Module DX, ENOIL2 in JDS-G135;
- Section 530, Lubricants & Hydraulics, of the John Deere Merchandise Sales Guide.

BREAK-IN ENGINE OIL—NORTH AMERICA

IMPORTANT: ONLY use a quality break-in oil in rebuilt or remanufactured engines for the **first 5 hours (maximum) of operation**. DO NOT use oils with heavier viscosity weights than SAE 5W-30 or oils meeting specifications API SG or SH, these oils will not allow rebuilt or remanufactured engines to break-in properly.

The following John Deere oil is **PREFERRED**:

• **BREAK-IN ENGINE OIL.**

John Deere **BREAK-IN ENGINE OIL** is formulated with special additives for aluminum and cast iron type engines to allow the power cylinder components (pistons, rings, and liners as well) to “wear-in” while protecting other engine components, valve train and gears, from abnormal wear. Engine rebuild instructions should be followed closely to determine if special requirements are necessary.

John Deere **BREAK-IN ENGINE OIL** is also recommended for non-John Deere engines, both aluminum and cast iron types.

The following John Deere oil is **also recommended**:

• **TORQ-GARD SUPREME®—SAE 5W-30.**

If the above recommended John Deere oils are not available, use a break-in engine oil meeting the following specification during the first 5 hours (maximum) of operation:

- SAE 5W-30—API Service Classification SE or higher.

IMPORTANT: After the break-in period, use the John Deere oil that is recommended for this engine.

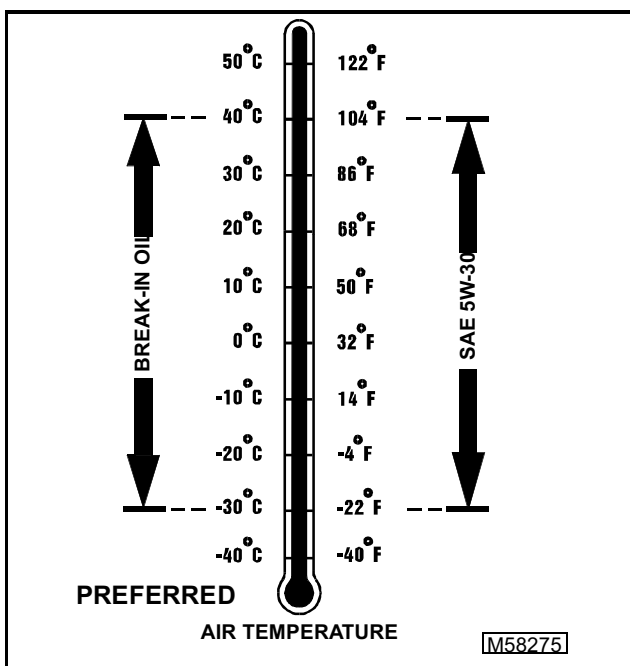

John Deere Dealers: You may want to cross-reference the following publications to recommend the proper oil for your customers:

- Module DX, ENOIL4 in JDS-G135;
- Section 530, Lubricants & Hydraulics, of the John Deere Merchandise Sales Guide;
- Lubrication Sales Manual PI7032.



BREAK-IN ENGINE OIL—EUROPE

IMPORTANT: ONLY use a quality break-in oil in rebuilt or remanufactured engines for the **first 5 hours (maximum) of operation**. DO NOT use oils with heavier viscosity weights than SAE 5W-30 or oils meeting CCMC Specification G5—these oils will not allow rebuilt or remanufactured engines to break-in properly.

The following John Deere oil is **PREFERRED**:

• **BREAK-IN ENGINE OIL.**

John Deere **BREAK-IN ENGINE OIL** is formulated with special additives for aluminum and cast iron type engines to allow the power cylinder components (pistons, rings, and liners as well) to “wear-in” while protecting other engine components, valve train and gears, from abnormal wear. Engine rebuild instructions should be followed closely to determine if special requirements are necessary.

John Deere **BREAK-IN ENGINE OIL** is also recommended for non-John Deere engines, both aluminum and cast iron types.

The following John Deere oil is **also recommended**:

• **TORQ-GARD SUPREME®—SAE 5W-30.**

If the above recommended John Deere oils are not available, use a break-in engine oil meeting the following specification during the first 5 hours (maximum) of operation:

- SAE 5W-30—CCMC Specification G4 or higher.

IMPORTANT: After the break-in period, use the John Deere oil that is specified for this engine.

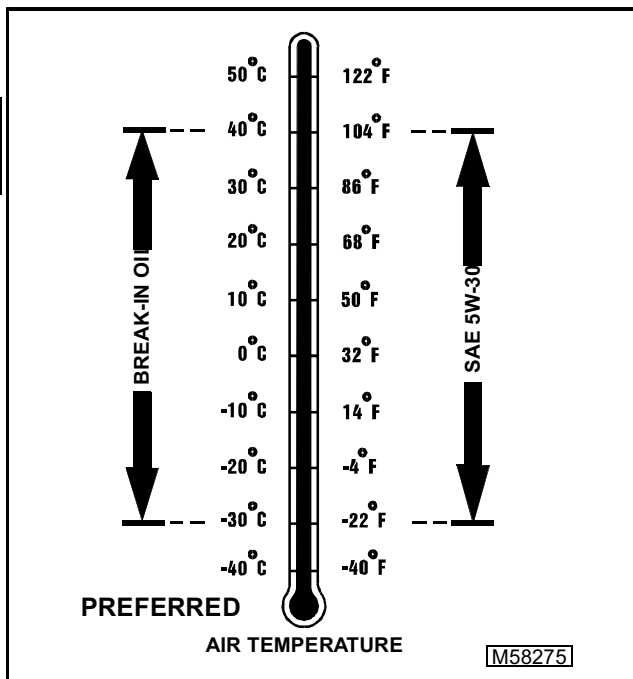

John Deere Dealers: You may want to cross-reference the following publications to recommend the proper oil for your customers:

- Module DX, ENOIL4 in JDS-G135;
- Section 530, Lubricants & Hydraulics, of the John Deere Merchandise Sales Guide.

TRANSMISSION GREASE—GEAR

Use the following gear grease based on the air temperature range. Operating outside of the recommended grease air temperature range may cause premature gear transmission failure.

IMPORTANT: ONLY use these specified greases in this transmission. DO NOT mix any other greases in this transmission. DO NOT use any BIO-GREASE in this transmission.

ONLY use the following **PREFERRED** grease as the input shaft needle bearing lubricant:

- Unirex N3 Grease®—M120263.

Other greases may be used as the input shaft needle bearing lubricant if they meet or exceed the following specification:

- ASTM D-1743, NLGI Grade 1.

ONLY use the following **PREFERRED** grease as the gear housing lubricant:

- Shell Darina D Grease®—AM119608.

Other greases may be used as the gear housing lubricant if they meet or exceed the following specification:

- ASTM D-1743, NLGI Grade 1.

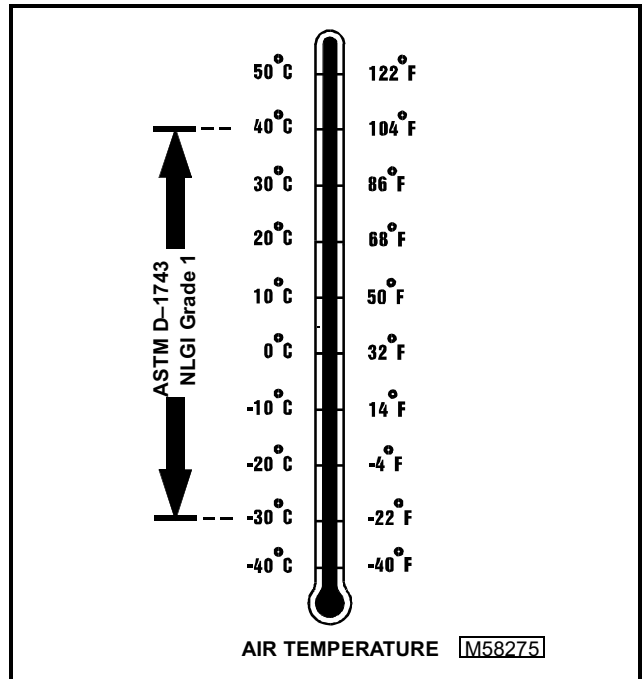

John Deere Dealers: You may want to cross-reference the following publications to recommend the proper grease for your customers:

- Module DX, GREA1 in JDS-G135;
- Section 530, Lubricants & Hydraulics, of the John Deere Merchandise Sales Guide;
- Lubrication Sales Manual PI7032.

HYDROSTATIC TRANSAXLE OIL—NORTH AMERICA

IMPORTANT: DO NOT use engine oil or “Type F” (Red) Automatic Transmission Fluid in this transmission. DO NOT mix any other oils in this transmission. DO NOT use BIO-HY-GARD® in this transmission.

Use recommended oil viscosity based on the expected air temperature range during the service interval.

The following John Deere transmission and hydraulic oil is **PREFERRED**:

- HY-GARD® — JDM J20C.
- TURF-GARD® — SAE 10W-30;
- PLUS-4® — SAE 10W-30;

TORQ-GARD SUPREME® SAE 30. Other oils may be used if above recommended John Deere oil is not available, provided they meet the following specification:

- John Deere Standard JDM J20C.

IMPORTANT: If minimum air temperature should fall below -25°C (-13°F), the transmission oil must be heated to at least five degrees above the lower limit before start-up or transmission may be damaged. For prolonged operation under heavy load in air temperatures above 50°C (122°F) reduce service interval by 50%.

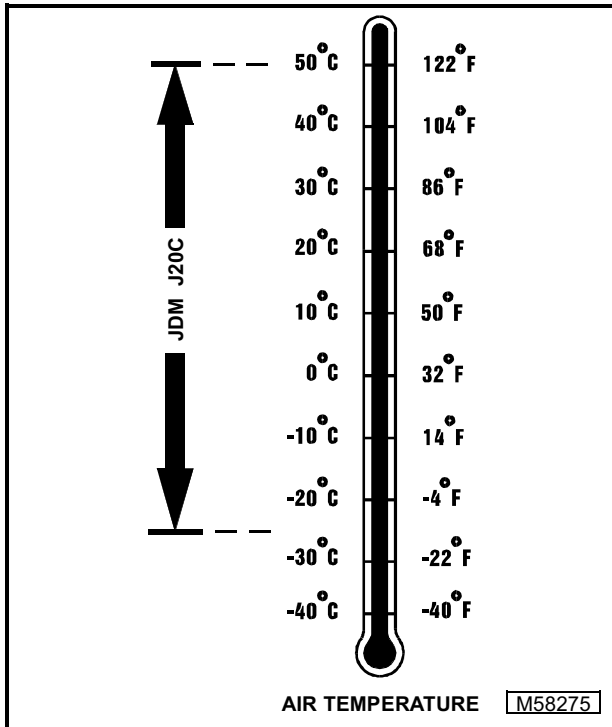

John Deere Dealers: You may want to cross-reference the following publications to recommend the proper oil for your customers:

- Module DX,ANTI in JDS-G135;
- Section 530, Lubricants & Hydraulics, of the John Deere Merchandise Sales Guide;
- Lubrication Sales Manual PI7032.

NOTE: Disregard the John Deere All Weather Hydrostatic Fluid (JDM J21A) listing—it has been eliminated from the specification.

HYDROSTATIC TRANSAXLE OIL—EUROPE

IMPORTANT: DO NOT use engine oil or “Type F” (Red) Automatic Transmission Fluid in this transmission. DO NOT mix any other oils in this transmission. DO NOT use BIO-HY-GARD® in this transmission.

The following John Deere transmission and hydraulic oil is **PREFERRED**:

- HY-GARD®—JDM J20C.

Other oils may be used if above recommended John Deere oil is not available, provided they meet the following specification:

- John Deere Standard JDM J20C.

IMPORTANT: If minimum air temperature should fall below -25°C (-13°F), the transmission oil must be heated to at least five degrees above the lower limit before start-up or transmission may be damaged. For prolonged operation under heavy load in air temperatures above 50°C (122°F) reduce service interval by 50%.

John Deere Dealers: You may want to cross-reference the following publications to recommend the proper oil for your customers:

- Module DX,ANTI in JDS-G135;
- Section 530, Lubricants & Hydraulics, of the John Deere Merchandise Sales Guide.

NOTE: Disregard the John Deere All Weather Hydrostatic Fluid (JDM J21A) listing—it has been eliminated from the specification.

ANTI-CORROSION GREASE SPECIFICATIONS

This anti-corrosion grease is formulated to provide the best protection against absorbing moisture, which is one of the major causes of corrosion. This grease is also superior in its resistance to separation and migration.

The following anti-corrosion grease is **PREFERRED**:

- DuBois MPG-2® Multi-Purpose Polymer Grease—M79292.

Other greases may be used if they meet or exceed the following specifications:

- John Deere Standard JDM J13A2, NLGI Grade 1.

IMPORTANT: Use only DuBois MPG-2® for electrical connector corrosion control. DO NOT substitute any other grease for electrical connector corrosion control.