

SABRE LAWN TRACTOR

MODELS: 1438 Gear 15.542 Automatic
 1542 Gear 1642 Gear
 15.538 Gear 1642 Automatic
 15.538 Automatic 1646 Automatic
 1542 Automatic 1642 Auto V-Twin
 15.542 Gear 1646 Auto V-Twin



TECHNICAL MANUAL

**John Deere
Worldwide Commercial and
Consumer Equipment Division**

TM-GX10238 (01Apr98)

This technical manual is written for an experienced technician and contains sections that are specifically for this product. It is a part of a total product support program.

The manual is organized so that all the information on a particular system is kept together. The order of grouping is as follows:

- Table of Contents
- Specifications
- Component Location
- System Schematic
- Theory of Operation
- Troubleshooting Chart
- Diagnostics
- Tests & Adjustments
- Repair

Note: Depending on the particular section or system being covered, not all of the above groups may be used.

Each section will be identified with a symbol rather than a number. The groups and pages within a section will be consecutively numbered.

We appreciate your input on this manual. If you find any errors, or want to comment on the layout of the manual, please mail your comments back to us.

All information, illustrations and specifications in this manual are based on the latest information available at the time of publication. The right is reserved to make changes at any time without notice.

COPYRIGHT® 1998
Deere and Co.
John Deere Worldwide Commercial and
Consumer Equipment Division
Horicon, WI
All rights reserved

Safety



Specifications and Information



Engine



Electrical



Gear Power Train



Hydrostatic Power Train



Steering



Attachments



Miscellaneous



SAFETY



HANDLE FLUIDS SAFELY-AVOID FIRES

- BE PREPARED FOR EMERGENCIES

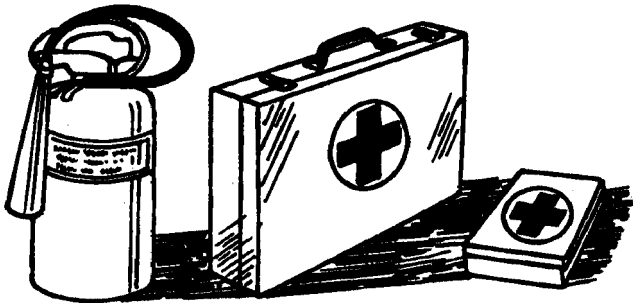

When you work around fuel, do not smoke or work near heaters or other fire hazards.

Store flammable fluids away from fire hazards. Do not incinerate or puncture pressurized containers.

Make sure machine is clean of trash, grease, and debris.

Do not store oily rags; they can ignite and burn spontaneously.

Be prepared if a fire starts.

Keep a first aid kit and fire extinguisher handy.

Keep emergency numbers for doctors, ambulance service, hospital, and fire department near your telephone.

HANDLE CHEMICAL PRODUCTS SAFELY

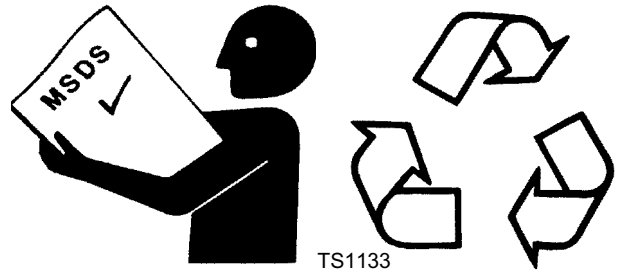

TS1133

Direct exposure to hazardous chemicals can cause serious injury. Potentially hazardous chemicals used include such items as lubricants, coolants, paints, and adhesives.

A Material Safety Data Sheet (MSDS) provides specific details on chemical products: physical and health hazards, safety procedures, and emergency response techniques. Check the MSDS before you start any job using a hazardous chemical. That way you will know exactly what the risks are and how to do the job safely. Then follow procedures and recommended equipment.

- DISPOSE OF WASTE PROPERLY

Improperly disposing of waste can threaten the environment and ecology. Potentially harmful waste includes oil, fuel, coolant, brake fluid, filters, and batteries. Use leakproof containers when draining fluids. Do not use food or beverage containers that may mislead someone into drinking from them. Do not pour waste onto the ground, down a drain, or into any water source. Inquire on the proper way to recycle or dispose of waste from your local environmental or recycling center.

USE CARE IN HANDLING AND SERVICING BATTERIES

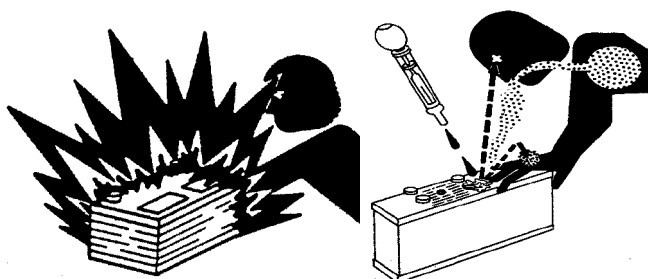

• PREVENT BATTERY EXPLOSIONS

- Keep sparks, lighted matches, and open flame away from the top of battery. Battery gas can explode.
- Never check battery charge by placing a metal object across the posts. Use a volt-meter or hydrometer.
- Do not charge a frozen battery; it may explode. Warm battery to 16°C (60°F).

• PREVENT ACID BURNS

- Sulfuric acid in battery electrolyte is poisonous. It is strong enough to burn skin, eat holes in clothing, and cause blindness if splashed into eyes.

• Avoid acid burns by:

1. Wearing eye protection and rubber gloves.
2. Avoiding breathing fumes from electrolyte.
3. Avoiding tipping battery.
4. Use proper jump start procedure.

• If you spill acid on yourself:

1. Flush your skin with water.
2. Apply baking soda to help neutralize the acid.
3. Flush your eyes with water for 10–15 minutes.
4. Get medical attention immediately.

• If acid is swallowed:

1. Drink large amounts of water or milk.
2. Then drink milk of magnesia, beaten eggs, or vegetable oil.
3. Get medical attention immediately.

USE SAFE SERVICE PROCEDURES



• WEAR PROTECTIVE CLOTHING

Wear close fitting clothing and safety equipment appropriate to the job.

Prolonged exposure to loud noise can cause impairment or loss of hearing. Wear a suitable hearing protective device such as earmuffs or earplugs to protect against objectionable or uncomfortable loud noises.

Operating equipment safely requires the full attention of the operator. Do not wear radio or music headphones while operating machine.



• SERVICE MACHINES SAFELY

Tie long hair behind your head. Do not wear a necktie, scarf, loose clothing, or necklace when you work near machine tools or moving parts. If these items were to get caught, severe injury could result.

Remove rings and other jewelry to prevent electrical shorts and entanglement in moving parts.

• USE PROPER TOOLS

Use tools appropriate to the work. Makeshift tools and procedures can create safety hazards. Use power tools only to loosen threaded parts and fasteners. For loosening and tightening hardware, use the correct size tools. **DO NOT** use U.S. measurement tools on metric fasteners. Avoid bodily injury caused by slipping wrenches. Use only service parts meeting John Deere specifications.

**Thanks very much for your reading,
Want to get more information,
Please click here, Then get the complete
manual**

JustClickHere 

NOTE:

**If there is no response to click on the link above,
please download the PDF document first, and then
click on it.**

**Have any questions please write to me:
admin@servicemanualperfect.com**

SAFETY



• PARK MACHINE SAFELY

1. Depress brake pedal fully.
2. Move park lever into lock position.
3. Check that shift lever has returned to neutral.
4. Make sure blade drive lever is pulled back fully.
5. Move throttle lever to SLOW IDLE position and allow engine to idle for approximately 30 seconds before turning key switch to OFF position. Remove the ignition key to prevent accidental starting.

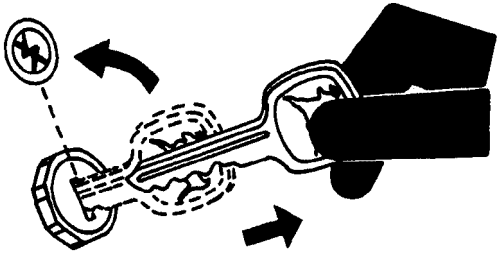

• Before working on the machine:

1. Lower all equipment to the ground.
2. Stop the engine and remove the key.
3. Disconnect the battery ground strap.
4. Hang a "DO NOT OPERATE" tag in operator station.

• SUPPORT MACHINE PROPERLY AND USE PROPER LIFTING EQUIPMENT

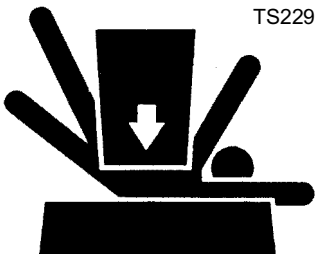

If you must work on a lifted machine or attachment, securely support the machine or attachment with jack stands rated to support the lifted load.

Do not support the machine on cinder blocks, hollow tiles, or props that may crumble under continuous load. Do not work under a machine that is supported solely by a jack. Follow recommended procedures in this manual.

Lifting heavy components incorrectly can cause severe personal injury or machine damage. Follow recommended procedure for removal and installation of components in the manual.

• WORK IN CLEAN AREA

• Before starting a job

1. Clean work area and machine:
2. Have all the necessary tools to do your job
3. Have the right parts on hand.
4. Read all instructions thoroughly; do not attempt shortcuts.

• ILLUMINATE WORK AREA SAFELY

Illuminate your work area adequately but safely. Use a portable safety light for working inside or under the machine. Make sure the bulb is enclosed by a wire cage. The hot filament of an accidentally broken bulb can ignite spilled fuel or oil.

• WORK IN VENTILATED AREA

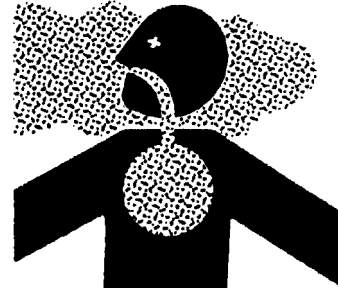

Engine exhaust fumes can cause sickness or death. If it is necessary to run an engine in an enclosed area, remove the exhaust fumes from the area with an exhaust pipe extension.

If you do not have an exhaust pipe extension, open the doors and get outside air into the area.

WARNING: California Proposition 65

Warning

Diesel engine exhaust and some of its constituents are known to the State of California to cause cancer, birth defects, and other reproductive harm.

Gasoline engine exhaust from this product contains chemicals known to the State Of California to cause cancer, birth defects, or other reproductive harm.

• **REMOVE PAINT BEFORE WELDING OR HEATING**

Avoid potentially toxic fumes and dust. Hazardous fumes can be generated when paint is heated by welding, soldering, or using a torch. Do all work outside or in a well ventilated area. Dispose of paint and solvent properly. Remove paint before welding or heating: If you sand or grind paint, avoid breathing the dust. Wear an approved respirator. If you use solvent or paint stripper, remove stripper with soap and water before welding. Remove solvent or paint stripper containers and other flammable material from area. Allow fumes to disperse at least 15 minutes before welding or heating.

• **AVOID HARMFUL ASBESTOS DUST**

Avoid breathing dust that may be generated when handling components containing asbestos fibers. Inhaled asbestos fibers may cause lung cancer.

Components in products that may contain asbestos fibers are brake pads and some gaskets. The asbestos used in these components is usually found in a resin or sealed in some way. Normal handling is not hazardous as long as airborne dust containing asbestos is not generated.

Avoid creating dust. Never use compressed air for cleaning. Avoid brushing or grinding material containing asbestos. When servicing, wear an approved respirator. A special vacuum cleaner is recommended to clean asbestos. If not available, apply a mist of oil or water on the material containing asbestos. Keep bystanders away from the area.

• **SERVICE TIRES SAFELY**

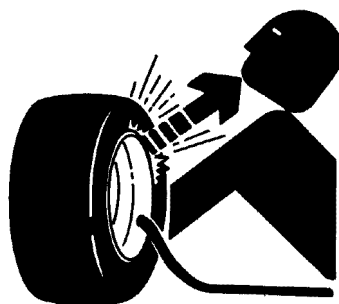

Explosive separation of a tire and rim parts can cause serious injury or death.

Do not attempt to mount a tire unless you have the proper equipment and experience to perform the job. Always maintain the correct tire pressure. Do not inflate the tires above the recommended pressure. Never weld or heat a wheel and tire assembly. The heat can cause an increase in air pressure resulting in a tire explosion. Welding can structurally weaken or deform the wheel.

When inflating tires, use a clip-on chuck and extension hose long enough to allow you to stand to one side and

NOT in front of or over the tire assembly. Use a safety cage if available.



- **Check wheels for low pressure, cuts, bubbles, damaged rims or missing retaining hardware.**

REPLACE DECALS



Replace missing or damaged Decals. See the machine operator's manual for correct safety sign placement.

LIVE WITH SAFETY



Before returning machine to customer, make sure machine is functioning properly, especially the safety systems. Install all guards and shields.

SAFETY



CONTENTS

	Page
SPECIFICATIONS	2
UNIFIED INCH TORQUE VALUES	6
METRIC TORQUE VALUES	7
GASOLINE SPECIFICATIONS	8
GASOLINE STORAGE	8
LUBRICANT SPECIFICATIONS	8
ENGINE OIL	8
GREASE	9
ALTERNATIVE LUBRICANTS	9
SYNTHETIC LUBRICANTS	9
OIL FILTERS	9
LUBRICANT STORAGE	9
SERIAL NUMBER LOCATIONS	10
TRACTOR IDENTIFICATION NUMBER	10
ENGINE SERIAL NUMBER	10
GEAR TRANSAXLE SERIAL NUMBER	10
HYDROSTATIC TRANSMISSION SERIAL NUMBER	10



SPECIFICATIONS

Engine:

Make Briggs and Stratton
 Style Vertical Shaft
 Models:
 14 Horsepower 287707
 15 Horsepower 28N700
 15.5 Horsepower 28N700
 16 Horsepower (Cast Iron Sleeve) 28Q777
 16 Horsepower (V-Twin) 303777
 Type Gasoline, Air Cooled, Single Cylinder, 4-Cycle
 Crankcase Oil Capacity:
 Single Cylinder without oil filter 48 oz (1.42 L)
 Single Cylinder with oil filter 56 oz (1.66 L)
 V-Twin with oil filter 56 oz (1.66 L)
 Oil: Warm Climate (Above 40°F) SE, SF, SG, SAE 30W
 Cold Climate (Below 40°F) SE, SF, SG, SAE 10W30

Electrical:

Ignition System Magnetron® Magneto Ignition
 Magneto Air Gap 0.25 - 0.35 mm (0.010 - 0.014 in.)
 Charging System Dual Circuit (AC/DC)
 Charging Capacity 2 - 4 amps, 14 volts DC@3600 rpm (Unregulated)
 Spark Plugs
 14, 15, 15.5 & 16 hp M78543 (Champion RC-12 YC)
 Spark Plug Air Gap 0.76 mm (0.030 in.)
 Battery Type BCI Group, U1
 Battery Cranking Amps 230 amps at 0° C (32° F)
 Battery Cold Cranking Amps 190 amps at 0° C (32° F)
 Battery Specific Gravity Above 1.225 Points
 Starter Type Bendix Inertia Drive
 Fuel Shut-Off Solenoid
 14, 15, 15.5 & 16 hp Replaceable (Below Carburetor Float Bowl)
 Headlight Bulbs Type 1156, 12 Volt

Fuel/Air System:

Carburetor Make Briggs & Stratton
 Carburetor Type Side Draft
 Throttle/Choke Unitized Control Linkage
 Carburetor Fuel Shut-Off Solenoid (Optional) Electric
 Fuel Delivery Gravity Flow
 Fuel Filter Replaceable Inline type
 Fuel Type Unleaded (87 Octane Minimum)
 Fuel Tank Capacity 4.7 L (1.25 gal)
 Air Filter Paper Element with Foam Pre-cleaner
 Muffler Type Anti-Backfire

Power Train:

Gear Transaxle—

Make Dana
 Model. Spicer H-D 4360 Transaxle
 Type. Five-Speed/Linear Shift

Domestic Ground Speeds (at FAST idle—2950 rpm) and Gear Ratios:

1st Gear. 2.4 km/hr (1.5 mph)
 2nd Gear. 3.2 km/hr (2.0 mph)
 3rd Gear. 5.0 km/hr (3.1 mph)
 4th Gear. 6.4 km/hr (4.0 mph)
 5th Gear. 8.0 km/hr (5.0 mph)
 Reverse. 3.7 km/hr (2.3 mph)

Brake Type Single, Internal Brake Disc

Lubrication—Input Shaft Needle Bearings Multi-Purpose Grease

Lubrication—Transaxle Multi-Purpose Grease

Capacity—Transaxle Oil 2.3 kg (5.07 lbs)

Hydro Transaxle—

Make Kanzaki
 Model. Tuff Torq® K-51 Transaxle
 Type. Hydrostatic

Ground Speeds (at FAST idle—2950 rpm):

Forward 0—8.5 km/hr (0—5.3 mph)
 Reverse 0—5.3 km/hr (0—3.3 mph)

Brake Type Single, Internal Disc Brake

Lubrication. 10W30 Engine Oil, Class CD

Reservoir. Internal

Capacity 2.5 L (2.4 qt)

Traction Drive Belt:

Gear—

New Belt Length 2686 ± 8 mm (105.75 ± 0.3 in.)
 Minimum Effective Length 2656 mm (104.57 in.)
 Maximum Effective Length 2736 mm (107.72 in.)

Hydro—K51 Transmission

New Belt Length 2435 ± 8 mm (95.87 ± 0.3 in.)
 Minimum Effective Length 2427 mm (95.55 in.)
 Maximum Effective Length 2443 mm (96.18 in.)

Mower Deck Drive Belt

38-Inch Deck—

Actual effective length 2407 ± 10 mm (94.76 ± .4 in.)

42-Inch Deck (Single Cylinder Engine)—

Actual effective length 2930 ± 10 mm (115.03 ± 0.4 in.)

42-Inch Deck (V-Twin Engine)—

Actual effective length 2921.8 ± 10 mm (115.03 ± 0.4 in.)

46-Inch Deck (Single Cylinder Engine)—

Actual effective length 3665 ± 10 mm (144.29 ± 0.4 in.)

46-Inch Deck (V-Twin Engine)—

Actual effective length 3640 ± 10 mm (143.10 ± 0.4 in.)



Mower Deck:

38-Inch Mower Deck—

Type	Rotary—Dual Spindles (Non-Serviceable)
Material Type	Stamped 2.5 mm (0.098 in.) Nominal Gauge Steel
Cutting Blade	Two—76 x 5 x 496 mm (3 x 0.2 x 19.5 in.)
Blade Cutting Edge30 ± 5° Angle
Blade Wing Lift/Height	40 ± 3 mm (1.57 ± 0.12 in.)
Overall Cutting Width	965 mm (38 in.)
Overall Width (w/o discharge chute)	1026 mm (40.4 in.)
Drive Type	Single V-Belt (With Spring Tension Idler)
Spindle Lubrication	None—Sealed Bearings
Lift Type	Manual—Operator’s Station
Cutting Settings	Seven: 25.4—101.6 mm (1.0—4.0 in.)

42-Inch Mower Deck—

Type	Rotary—Dual Spindles (Non-Serviceable)
Material Type	Stamped 2.5 mm (0.098 in.) Nominal Gauge Steel
Cutting Blade	Two—57 x 4 x 545 mm (2.25 x 0.16 x 21.4 in.)
Blade Cutting Edge30 ± 5° Angle
Blade Wing Lift/Height	22 ± 2 mm (0.87 ± 0.08 in.)
Overall Cutting Width	1066 mm (42 in.)
Overall Width (w/o discharge chute)	1118 mm (44.0 in.)
Drive Type	Single V-Belt (With Spring Tension Idler)
Spindle Lubrication	None—Sealed Bearings
Lift Type	Manual—Operator’s Station
Cutting Settings	Seven: 25.4—101.6 mm (1.0—4.0 in.)

46-Inch Mower Deck—

Type	Rotary—Triple Spindles (Non-Serviceable)
Material Type	Stamped 2.5 mm (0.098 in.) Nominal Gauge Steel
Cutting Blade	Three—50.8 x 5 x 407.4 mm (2 x 0.2 x 16 in.)
Blade Cutting Edge30 ± 5° Angle
Blade Wing Lift/Height	20.3 ± 3 mm (0.8 ± 0.12 in.)
Overall Cutting Width	1168.4 mm (46 in.)
Overall Width (W/O Discharge Chute)	1308 mm (51.5 in.)
Drive Type	Single V-Belt (With Spring Tension Idler)
Spindle Lubrication	None—Sealed Bearings
Lift Type	Manual—Operator’s Station
Cutting Settings	Seven: 25.4 — 101.6 mm (1.0 — 4.0 in.)



Chassis:

Wheelbase	1178.2 mm (46.39 in.)
Overall Length	1524 mm (60 in.)
Overall Width (W/O Mower Deck)	908 mm (35.75 in.)
Height	980 mm (38.6 in.)
Average Overall Weight 38 inch (With Mower Deck, No Fuel)	177.35 kg (391 lbs)
Average Overall Weight 42 inch (With Mower Deck, No Fuel)	185.52 kg (409 lbs)
Average Overall Weight 46 inch (With Mower Deck, No Fuel)	191.42 kg (422 lbs)
Hitch Capacity—	
Export:	
Horizontal Pull Maximum25 kg (56 lbs)
Tongue Weight Maximum	6.8 kg (15 lbs)
Domestic:	
Trailer Load Maximum	136 kg (300 lbs)
Trailer Tongue Weight Maximum	22.6 kg (50 lbs)



Steering:

Type	Manual—Pinion/Sector
Axle Pivot Hub	Shim Adjustable
Lubrication	Multipurpose Grease
Lubrication Interval	10 hrs (Maximum)
Toe-In	6 mm (0.24 in.) — Non-Adjustable
Turning Radius	584 mm (23 in.)









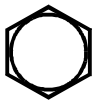

Wheels:

Size—	
Front	6.0 x 4.50
Rear	8.0 x 6.18

Tires:

Size—	
Front	13 x 6.50—6 NHS (2 ply)
Rear	18 x 9.50—8 NHS (2 ply)
Pressure—	
Front (with mower deck)	97 kPa (14 psi)
Rear (with mower deck)	69 kPa (10 psi)

UNIFIED INCH TORQUE VALUES

SAE Grade and Head Markings	1 or 2 ^b No Marks 	5  5.1  5.2 	8  8.2 
	2 No Marks 	5  	8  

Size	Grade 1				Grade 2 ^b				Grade 5, 5.1 or 5.2				Grade 8 or 8.2			
	Lubricated ^a		Dry ^a		Lubricated ^a		Dry ^a		Lubricated ^a		Dry ^a		Lubricated ^a		Dry ^a	
	Nm	lb-ft	Nm	lb-ft	Nm	lb-ft	Nm	lb-ft	Nm	lb-ft	Nm	lb-ft	Nm	lb-ft	Nm	lb-ft
1/4	3.8	2.8	4.7	3.5	6	4.4	7.5	5.5	9.5	7	12	9	13.5	10	17	12.5
5/16	7.7	5.7	9.8	7.2	12	9	15.5	11.5	19.5	14.5	25	18.5	28	20.5	35	26
3/8	13.5	10	17.5	13	22	16	27.5	20	35	26	44	32.5	49	36	63	46
7/16	22	16	28	20.5	35	26	44	32.5	56	41	70	52	80	59	100	74
1/2	34	25	42	31	53	39	67	49	85	63	110	80	120	88	155	115
9/16	48	35.5	60	45	76	56	95	70	125	92	155	115	175	130	220	165
5/8	67	49	85	63	105	77	135	100	170	125	215	160	240	175	305	225
3/4	120	88	150	110	190	140	240	175	300	220	380	280	425	315	540	400
7/8	190	140	240	175	190	140	240	175	490	360	615	455	690	510	870	640
1	285	210	360	265	285	210	360	265	730	540	920	680	1030	760	1300	960
1-1/8	400	300	510	375	400	300	510	375	910	670	1150	850	1450	1075	1850	1350
1-1/4	570	420	725	535	570	420	725	535	1280	945	1630	1200	2050	1500	2600	1920
1-3/8	750	550	950	700	750	550	950	700	1700	1250	2140	1580	2700	2000	3400	2500
1-1/2	990	730	1250	930	990	730	1250	930	2250	1650	2850	2100	3600	2650	4550	3350

DO NOT use these values if a different torque value or tightening procedure is given for a specific application. Torque values listed are for general use only. Check tightness of fasteners periodically.

Shear bolts are designed to fail under predetermined loads. Always replace shear bolts with identical grade.

Fasteners should be replaced with the same or higher grade. If higher grade fasteners are used, these should only be tightened to the strength of the original.

Make sure fasteners threads are clean and that you properly start thread engagement. This will prevent them from failing when tightening.

Tighten plastic insert or crimped steel-type lock nuts to approximately 50 percent of the dry torque shown in the chart, applied to the nut, not to the bolt head.





















Tighten toothed or serrated-type lock nuts to the full torque value.

^a "Lubricated" means coated with a lubricant such as engine oil, or fasteners with phosphate and oil coatings.

"Dry" means plain or zinc plated without any lubrication.

^b Grade 2 applies for hex cap screws (not hex bolts) up to 152 mm (6 in.) long. Grade 1 applies for hex cap screws over 152 mm (6 in.) long, and for all other types of bolts and screws of any length.

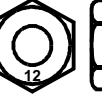
METRIC TORQUE VALUES

Property Class and Head Markings	4.8		8.8		9.8		10.9		12.9	
										
Property Class and Nut Markings	5		10		10		10		12	
										

Size	Class 4.8				Class 8.8 or 9.8				Class 10.9				Class 12.9			
	Lubricated ^a		Dry ^a		Lubricated ^a		Dry ^a		Lubricated ^a		Dry ^a		Lubricated ^a		Dry ^a	
	Nm	lb-ft	Nm	lb-ft	Nm	lb-ft	Nm	lb-ft	Nm	lb-ft	Nm	lb-ft	Nm	lb-ft	Nm	lb-ft
M6	4.7	3.5	6	4.4	9	6.6	11.5	8.5	13	9.5	16.5	12.5	15.5	11.5	19.5	14.5
M8	11.5	8.5	14.5	10.7	22	16	28	20.5	32	23.5	40	29.5	37	27.5	47	35
M10	23	17	29	21	43	32	55	40	63	46	80	59	75	55	95	70
M12	40	29.5	50	37	75	55	95	70	110	80	140	105	130	95	165	120
M14	63	46	80	59	120	88	150	110	175	130	220	165	205	150	260	190
M16	100	74	125	92	190	140	240	175	275	200	350	225	320	235	400	300
M18	135	100	175	125	265	195	330	245	375	275	475	350	440	325	560	410
M20	190	140	245	180	375	275	475	350	530	390	675	500	625	460	790	580
M22	265	195	330	245	510	375	650	480	725	535	920	680	850	625	108	800
M24	330	245	425	315	650	480	820	600	920	680	115	850	108	800	135	100
M27	490	360	625	460	950	700	1200	885	1350	1000	1700	1250	1580	1160	200	1500
M30	660	490	850	625	1290	950	1630	1200	1850	1350	2300	1700	2140	1700	2700	2000
M33	900	665	1150	850	1750	1300	2200	1625	2500	1850	3150	2325	2900	2150	3700	2730
M36	1150	850	1450	1075	2250	1650	2850	2100	3200	2350	4050	3000	3750	2770	4750	3500

DO NOT use these values if a different torque value or tightening procedure is given for a specific application. Torque values listed are for general use only. Check tightness of fasteners periodically.

Shear bolts are designed to fail under predetermined loads. Always replace shear bolts with identical property class.

Fasteners should be replaced with the same or higher property class. If higher property class fasteners are used, these should only be tightened to the strength of the original.

Make sure fasteners threads are clean and that you properly start thread engagement. This will prevent them from failing when tightening.

Tighten plastic insert or crimped steel-type lock nuts to approximately 50 percent of the dry torque shown in the chart, applied to the nut, not to the bolt head. Tighten toothed or serrated-type lock nuts to the full torque value.

^a "Lubricated" means coated with a lubricant such as engine oil, or fasteners with phosphate and oil coatings. "Dry" means plain or zinc plated without any lubrication.

GASOLINE SPECIFICATIONS



CAUTION

Handle fuel with care, it is highly flammable. **DO NOT** refuel machine:

- Indoors. Always fill fuel tank outdoors.
- While you smoke.
- When machine is near and open flame or sparks.
- When engine is running. **STOP** engine.
- When engine is hot. Allow it to cool.

Help prevent fires:

- Fill fuel tank only to bottom of filler neck.
- Clean oil, grease and dirt from machine.
- Clean up spilled fuel immediately.
- Do not store machine with fuel in tank in a building where fumes may reach an open flame or spark.

To prevent fire and explosion caused by static electric discharge while you fill tank:

- Use approved, non-metal fuel container.
- When using a funnel, **MAKE SURE** it is **PLASTIC**.
- Avoid using a funnel which has a metal screen or filter.

IMPORTANT: To avoid engine damage:

- DO NOT mix oil with gasoline
- Use only clean oil and fuel
- Use clean approved containers and funnels.
- Store oil and fuel in an area protected from dust, moisture and other contamination.

Unleaded fuel is recommended because it burns cleaner and leaves less unburned deposits in engine combustion chamber. Regular unleaded gasoline with an anti-knock index of 85 octane or higher may be used. Use of gasohol is acceptable as long as the ethyl alcohol blend does not exceed 11 percent. Do not use gasoline that contains Methanol.

Fill fuel tank at end of each day's operation. Fill only to bottom of filler neck.

GASOLINE STORAGE

Keep fuel in a clean container in a protected area. Do not use deicers to remove water from fuel. Do not depend on fuel filters to remove water.

If possible, install a water separator at the storage tank outlet.

IMPORTANT: Keep all dirt, scale, water or other foreign material out of fuel.

If mower is stored for the winter, add gasoline storage stabilizer to the fuel. Follow directions on can.

LUBRICANT SPECIFICATIONS

ENGINE OIL

Use oil viscosity based on the expected air temperature range during the period between oil changes.

The following oil is preferred:

- 10W30

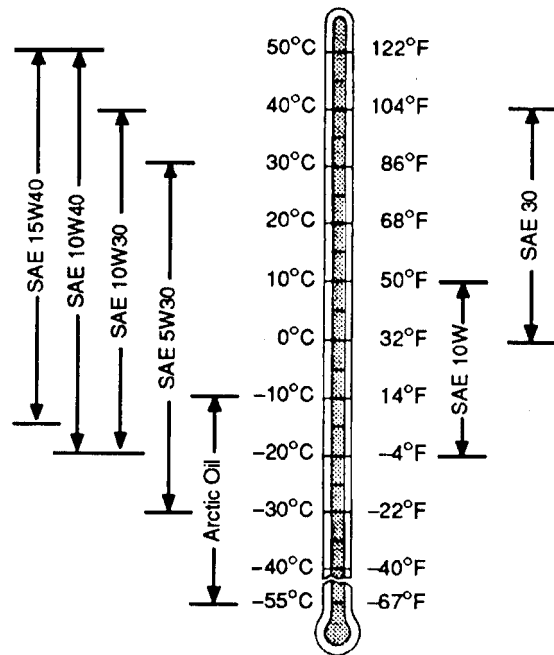

Other oils may be used if they meet one of the following:

- API Service Classification SG
- API Service Classification SF
- CCMC Specification G4

Oils meeting Military Specification MIL-L-46167B may be used as arctic oils.

GREASE

Use grease based on the expected air temperature range during the service interval.

The following greases are preferred:

- MOLY HIGH TEMPERATURE EP GREASE
- HIGH TEMPERATURE EP GREASE
- MULTI-PURPOSE GREASE

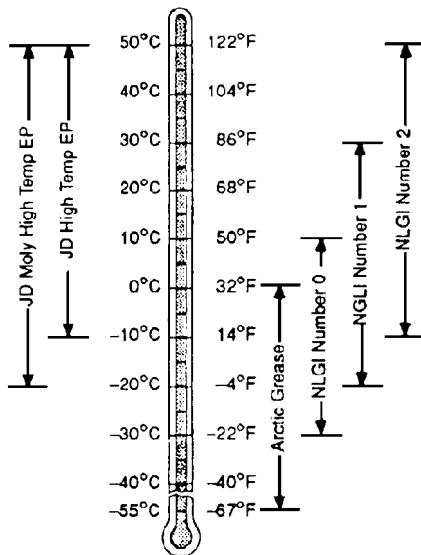

Other greases may be used if they meet one of the following:

- SAE Multipurpose EP Grease with a maximum of 5% molybdenum disulfide.
- SAE Multipurpose EP Grease

Greases meeting Military Specification MIL-G-10924F may be used as arctic grease.

ALTERNATIVE LUBRICANTS

Conditions in certain geographical areas outside the United States and Canada may require different lubricant recommendations than these printed in this manual or the operator's manual. Consult with your John Deere Dealer, or Sales Branch to obtain the alternative lubricant recommendations.

SYNTHETIC LUBRICANTS

Synthetic lubricants may be used in John Deere equipment if they meet the applicable performance requirements (industry classification and/or military specification) as shown in this group.

The recommended temperature limits and service or oil change intervals should be maintained as shown in the operator's manual.

Avoid mixing different brands, grades, or types of oil. Oil manufacturers blend additive in their oils to meet certain specifications and performance requirements. Mixing different oils can interfere with the proper functioning of these additives and degrade lubricant performance.

OIL FILTERS

Filtration of oils is critical to proper lubrication. Always change filters regularly.

Use filters meeting John Deere performance specification.

LUBRICANT STORAGE

This machine can operate at top efficiency only if clean lubricants are used.

Use clean containers to handle all lubricants. Store them in an area protected from dust, moisture, and other contamination. Store drums on their sides.

SERIAL NUMBER LOCATIONS

When working on machines or components that are covered by warranty, it is **IMPORTANT** that you include the tractor identification number and the component serial numbers on the warranty claim form.

The location of tractor identification number and component serial numbers are shown below.



TRACTOR IDENTIFICATION NUMBER

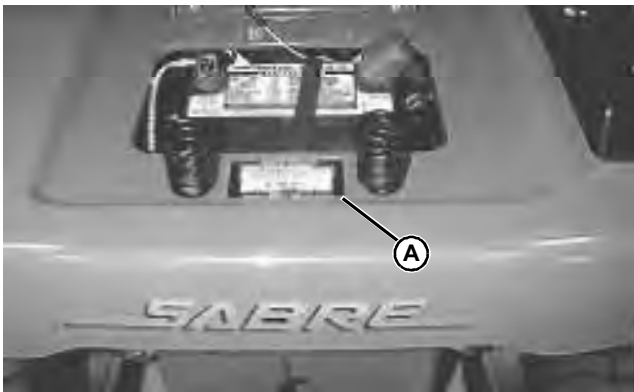

Tractor identification number plate (A) is located on the rear of frame or under seat.

ENGINE SERIAL NUMBER

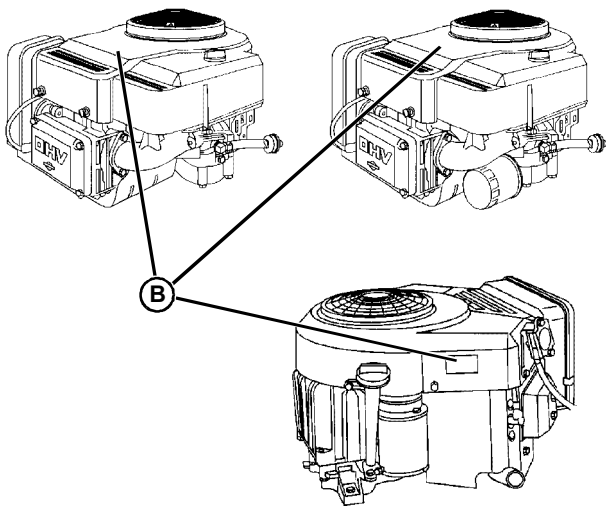

Tractor engine serial number sticker (B) is located on fan shroud.

GEAR TRANSAXLE SERIAL NUMBER

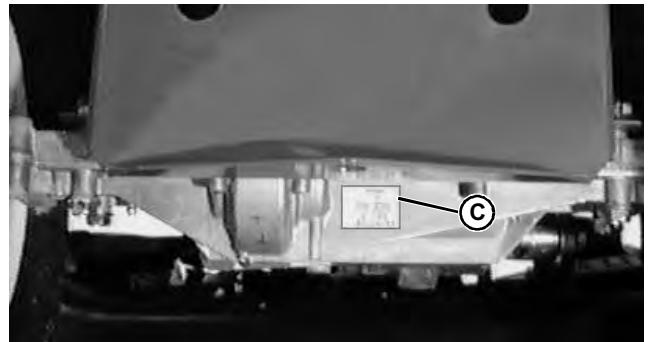

Gear transaxle serial number sticker (C) is on rear of housing.

HYDROSTATIC TRANSMISSION SERIAL NUMBER

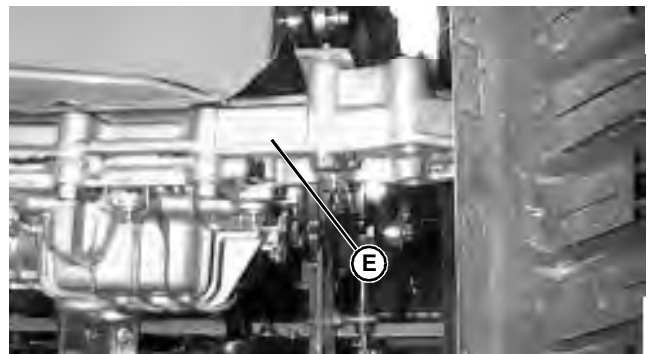

Serial number (E) is located on a bar coded label located on the right rear side of the transaxle.

CONTENTS

	Page
SPECIFICATIONS	3
SERVICE EQUIPMENT AND TOOLS	3
OTHER MATERIALS	3
REPAIR	4
ENGINE REMOVAL	4
ENGINE INSTALLATION	5



The engines used on Sabre products are warranted by the manufacturer - Briggs & Stratton Corporation.
Please refer to the Owners Manual supplied with your machine for applicable Briggs & Stratton Owners Warranty Policy.

