



# 9940 Cotton Picker



## TECHNICAL MANUAL 9940 Cotton Picker

TM1356 (01SEP85) English

**TM1356 (01SEP85)**

LITHO IN U.S.A.  
ENGLISH

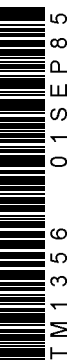



# 9940 COTTON PICKER TECHNICAL MANUAL TM-1356 (SEP-85)

## CONTENTS

### Publication Number Change

This technical manual was formerly TM-1241. The number was changed when engine information was removed. Some pages still carry the old publication number. For engine information, refer to Engine Component Technical Manual, CTM-1.

### SECTION 10—GENERAL

- Group 00—General Specifications
- Group 05—Predelivery, Delivery and After-Sale Services
- Group 10—Tune-Up and Adjustment
- Group 15—Fuels and Lubricants

### SECTION 20—ENGINE REPAIR

- Group 05—Remove and Install Engine
- Group 29—Remove/Install Cooling System

### SECTION 30—FUEL AND AIR REPAIR

- Group 00—Specifications and Special Tools
- Group 04—Remove/Install Air Intake System
- Group 09—Remove/Install Diesel Fuel System

### SECTION 40—ELECTRICAL REPAIR

- Group 00—Specifications and Special Tools
- Group 10—Charging Circuit Repair
- Group 15—Starting Circuit Repair
- Group 20—Lights, Instruments, and Accessory Circuits Repair

### SECTION 50—POWER TRAIN REPAIR

- Group 00—Specifications and Special Tools
- Group 10—Transmission
- Group 15—Axles and Differential
- Group 25—Sundstrand Hydrostatic Drive
- Group 26—Eaton Hydrostatic Drive

### SECTION 60—STEERING/BRAKES REPAIR

- Group 00—Specifications and Special Tools
- Group 05—Steering
- Group 10—Brakes

### SECTION 70—HYDRAULIC REPAIR

- Group 00—Specifications and Special Tools
- Group 05—Reservoir
- Group 10—Hydraulic Pump
- Group 15—Main Control Valve
- Group 20—Hydraulic Cylinders
- Group 25—Hydraulic Motors
- Group 30—Height Control

### SECTION 80—AXLES AND WHEELS REPAIR

- Group 00—Specifications
- Group 05—Guide Axle
- Group 10—Wheels

### SECTION 90—OPERATOR STATION REPAIR

- Group 00—Specifications and Special Tools
- Group 05—Air Conditioning System
- Group 10—Heating System
- Group 15—Miscellaneous Components

### SECTION 120—PICKING UNITS REPAIR

- Group 00—Specifications and Special Tools
- Group 05—Picking Units Removal and Installation
- Group 10—Grid Bars and Pressure Plates
- Group 15—Spindles and Picker Bars
- Group 20—Picker Drums, Drive Shafts, and Gears
- Group 25—Idler Gears and Bearings
- Group 30—Doffers, Stub Shaft and Drive
- Group 35—Moistener Columns
- Group 40—Gear Cases, Universal Joints, and Countershafts
- Group 45—Picking Unit Cabinets and Cam Tracks

### SECTION 130—MOISTENER AND AIR SYSTEMS REPAIR

- Group 00—Specifications
- Group 05—Moistener System
- Group 10—Air System

**CONTENTS—Continued**

**SECTION 220—ENGINE OPERATION AND TESTS**

- Group 00—Specifications and Special Tools
- Group 05—System Operation
- Group 10—System Tests and Diagnosis

**SECTION 230—FUEL/AIR OPERATIONS AND TESTS**

- Group 00—Specifications and Special Tools
- Group 05—Air Intake System
- Group 10—Diesel Fuel System

**SECTION 240—ELECTRICAL OPERATION AND TESTS**

- Group 00—Specifications and Special Tools
- Group 05—General Information and Diagrams
- Group 10—Charging Circuit
- Group 15—Starting Circuit
- Group 20—Lights, Instruments, and Accessory Circuits

**SECTION 250—POWER TRAIN OPERATION AND TESTS**

- Group 00—Specifications and Special Tools
- Group 10—Transmission
- Group 15—Axles and Differential
- Group 25—Hydrostatic Drive

**SECTION 260—STEERING/BRAKES OPERATION AND TESTS**

- Group 00—Specifications and Special Tools
- Group 05—Steering
- Group 10—Brakes

**SECTION 270—HYDRAULIC OPERATION AND TESTS**

- Group 00—Specifications and Special Tools
- Group 05—System Operation and Tests
- Group 10—Hydraulic Pump
- Group 15—Main Hydraulic Valve
- Group 20—Hydraulic Cylinders
- Group 25—Hydraulic Motors
- Group 30—Height Control

**SECTION 290—OPERATOR STATION OPERATION AND TESTS**

- Group 00—Specifications and Special Tools
- Group 05—Pressurizer System
- Group 10—Air Conditioning System Operation
- Group 15—Air Conditioning System Tests and Diagnosis
- Group 20—Heating System

**SECTION 325—PICKING, MOISTENER, AND AIR SYSTEMS**

- Group 00—Specifications and Special Tools
- Group 05—Systems Operation and Diagnosis

*All information, illustrations and specifications contained in this technical manual are based on the latest information available at the time of publication. The right is reserved to make changes at any time without notice.*

COPYRIGHT® 1985  
DEERE & COMPANY  
Moline, Illinois  
All rights reserved  
Previous Editions  
Copyright® 1981, 1982, 1983, 1984 Deere & Company  
A JOHN DEERE ILLUSTRATION

N01;0000 B 300785

**Thanks very much for your reading,  
Want to get more information,  
Please click here, Then get the complete  
manual**

**JustClickHere** 

**NOTE:**

**If there is no response to click on the link above,  
please download the PDF document first, and then  
click on it.**

**Have any questions please write to me:  
[admin@servicemanualperfect.com](mailto:admin@servicemanualperfect.com)**

## INTRODUCTION

This manual is part of a total service support program.

### FOS Manuals—reference

### Technical Manuals—machine service

### Component Manuals—component service

*Fundamentals of Service (FOS) Manuals* cover basic theory of operation, fundamentals of troubleshooting, general maintenance, and basic types of failures and their causes. FOS Manuals are for training new personnel and for reference by experienced technicians.

*Technical Manuals* are concise service guides for specific machines. Technical manuals are on-the-job guides containing only the vital information needed by an experienced service technician.

*Component Technical Manuals* are concise service guides for specific components. Component technical manuals are written as stand alone manuals covering multiple machine applications.

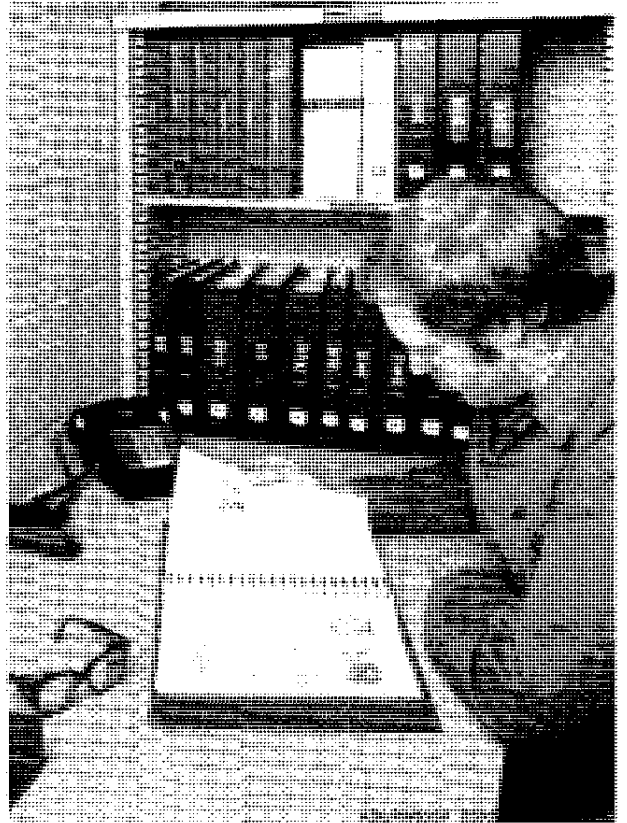

## FEATURES OF THIS TECHNICAL MANUAL

John Deere ILLUSTRATION format emphasizing illustrations and concise instructions in easy-to-use modules.

Emphasis on diagnosis, analysis, and testing so you can understand the problem and correct it.

Diagnostic information presented with the most logical and easiest to isolate problems first to help you identify the majority of routine failures quickly.

Step-by-step instructions for teardown and assembly.

Summary listing at the beginning of each group of all applicable specifications, wear tolerances, torque values, essential tools, and materials needed to do the job.

An emphasis throughout on safety—so you do the job right without getting hurt.

This technical manual was planned and written for you—an experienced service technician. Keep it in a permanent binder in the shop where it is handy. Refer to it when you need to know correct service procedures or specifications.

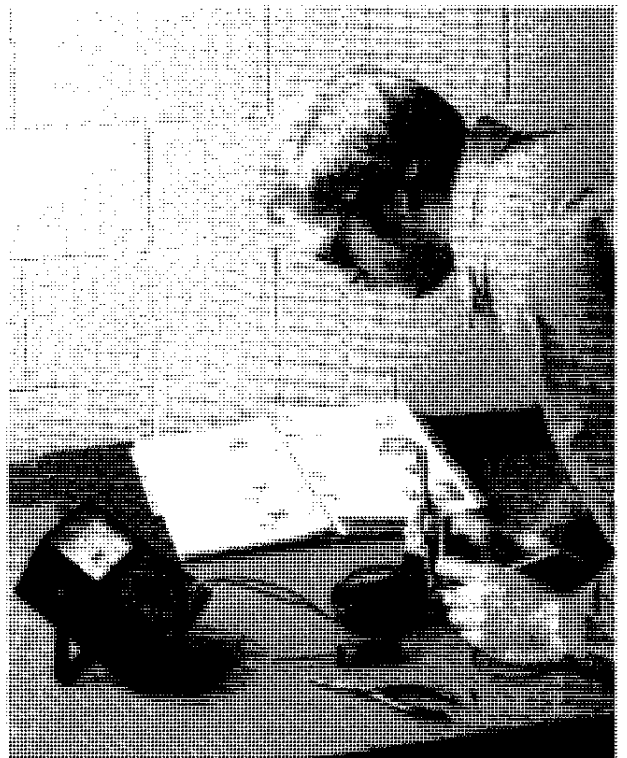

AB6;RW5560 053;INTR03 030785

## USING TABS

To fully utilize this technical manual, you must understand how it is organized.

Only two tab colors are used--green and yellow. Each color represents a different type of information.

Spend a minute reading this now and save many minutes of searching later.

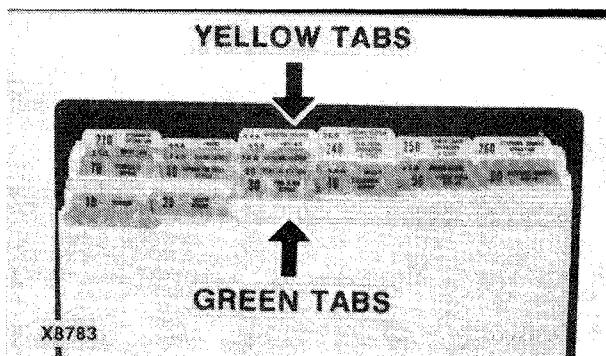

A68:X8783 N01:0000 D 261180

## GREEN TAB SECTIONS

The green tab sections are repair sections that tell how to repair the components of the various systems.

Repair of a component includes:

- Removal from machine (when necessary)
- Disassembly
- Inspection
- Replacement of parts
- Assembly
- Adjustment
- Installation on machine (when necessary)

The numbers used for the repair (green tab) sections are part of an overall service publication numbering system. The numbers identify the same sections in the parts catalog, flat rate manual, service information bulletins, and service training courses.

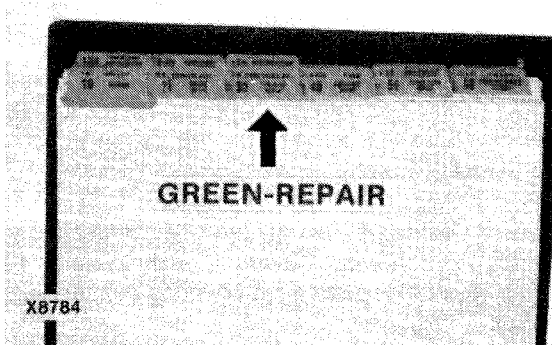

A68:X8784 N01:0000 E 261180

## YELLOW TAB SECTIONS

Each yellow tab section contains information on:

- System Operation
- System Tests

System operation explains how the system and its components work.

System tests tell how to test the system and diagnose the problem.

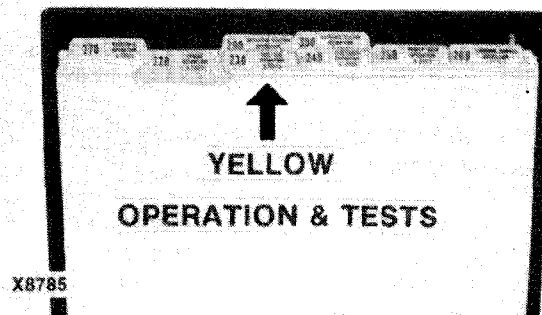

A68:X8785 N01:0000 F 261180

### TAB POSITIONS

Each green tab and its corresponding yellow tab have the same tab position. This is to help you quickly locate the related information.

Tab Color	Tab Position	Section No.	Description
Green	2nd	20	Engine Repair
Yellow	2nd	220	Engine Operation and Tests

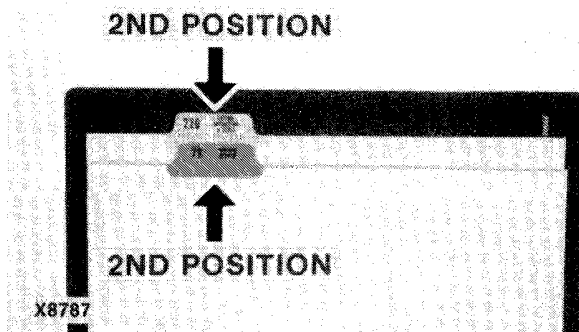

A68:X8787 N01:0000 G 261180

### THREE-STEP PROCEDURE

Use the following three-step procedure to locate the desired information.

1. Determine the type of information you need. Is it repair, operation, or tests?
2. Go to the appropriate section tab:  
Green for Repair  
Yellow for Operation or Tests

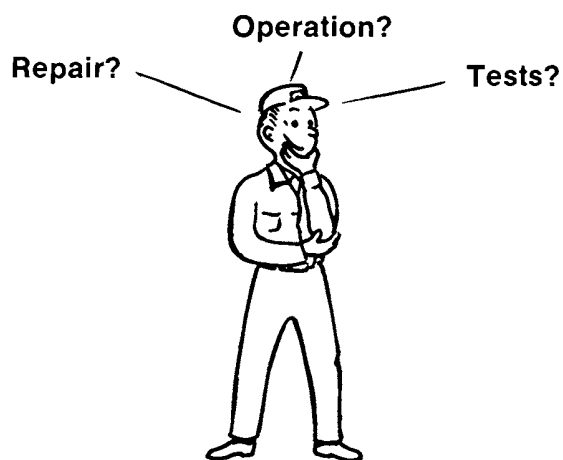

X8788 TYPE OF INFORMATION?

A68:X8788 N01:0000 H 261180



Introduction

3. Use the table of contents on the first page of the section to locate the information.

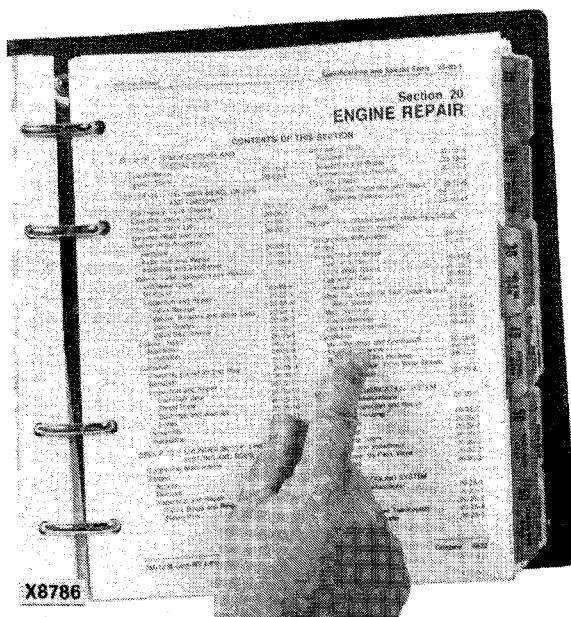

A66:X8786 N01:0000 1 261180

## OBSERVE SAFETY RULES



This safety alert symbol identifies important safety messages in this manual and on the picker. When you see this symbol, be alert to the possibility of personal injury and carefully read the message that follows.

Avoid loose clothing that can catch in moving parts and put you out of work.

Wear your safety glasses while on the job.

Avoid working on equipment with the engine running. If it is necessary to make checks with the engine running, ALWAYS USE TWO PEOPLE—with the operator, at the controls, able to see the person doing the checking. Also, put the transmission in neutral, set the brake, and apply safety locks provided. KEEP HANDS AWAY FROM MOVING PARTS.

Keep transmission and brake control units properly adjusted at all times. Before making adjustments, stop engine.

Before removing any housing covers, stop engine. Take all objects from your pockets which could fall into the opened housings. Don't let adjusting wrenches fall into opened housings.

Don't attempt to check belt tension while the engine is running.

Don't adjust the fuel system while the machine is in motion.

Before repairing the electrical system, or performing a major overhaul, make sure the batteries are disconnected.

A68; N01,0000 J 261:RD

## AVOID FIRE HAZARDS

Be prepared if an accident or fire should occur. Know where the first aid kit and the fire extinguishers are located—know how to use them.

Don't smoke while refueling or handling highly flammable material.

Shut off the engine when refueling.

Use care in refueling if the engine is hot.

Don't use open pans of gasoline or diesel fuel for cleaning parts. Use good commercial, nonflammable solvents.

Provide adequate ventilation when charging batteries.

Don't check battery charge by placing metal objects across the posts.

Don't allow sparks or open flame near batteries.

Don't smoke near battery.

Never check fuel, battery electrolyte, or coolant levels with an open flame.

Never use an open flame to look for leaks anywhere on the equipment.

Never use an open flame as light anywhere on or around the equipment.

When preparing engine for storage, remember that inhibitor is volatile and therefore dangerous. Seal and tape openings after adding the inhibitor. Keep container tightly closed when not in use.

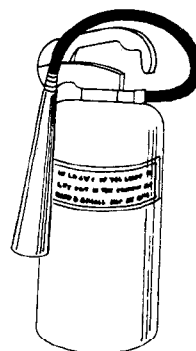

N35540

A68/N35540 N01/0000 K 261180

## PROTECT AGAINST NOISE

Prolonged exposure to loud noise can cause impairment or loss of hearing.

Wear a suitable hearing protective device such as earmuffs (A) or earplugs (B) to protect against objectionable or uncomfortable loud noises.

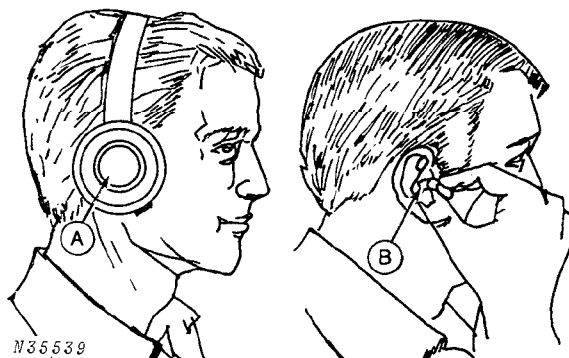

N35539

A68/N35539 N01/0000 L 261180

## AVOID HIGH PRESSURE-FLUIDS

Escaping fluid under pressure can penetrate the skin causing serious injury. Relieve pressure before disconnecting hydraulic or other lines. Tighten all connections before applying pressure. Keep hands and body away from pinholes and nozzles which eject fluids under high pressure. Use a piece of cardboard or paper to search for leaks. Do not use your hand.

If ANY fluid is injected into the skin, it must be surgically removed within a few hours by a doctor familiar with this type of injury or gangrene may result.

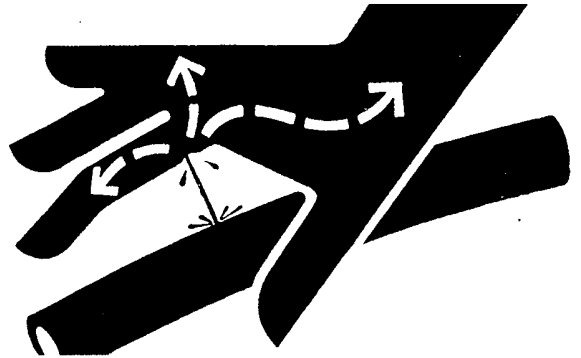

A68;X9811 N01;0000 W 051182

## USE ADEQUATE SERVICE FACILITIES

Keep the service area clean and dry. Wet or oily floors are slippery. Wet spots can be dangerous when working with electrical equipment.

Make sure the service area is adequately vented.

Periodically check the shop exhaust system for leakage. Engine exhaust gas is dangerous.

Be sure all electrical outlets and tools are properly grounded.

Use adequate light for the job at hand.

Service the machine on a level, hard-surfaced area.

Use lifting equipment and safety stands which have adequate strength for the job being performed.

A68; N01;0000 N 051182

*Introduction*

**USE BLOCKS WHEN NEEDED**

Block the wheels to keep the cotton picker from moving while it is being serviced.

Whenever the engine is to be removed for service, block the basket securely, so it will not fall.

Whenever working under the picking units, block the picking units so they will not fall.

A68; N03;0000 O 261180

# Section 10 GENERAL

## CONTENTS

	Page		Page
<b>GROUP 00 - GENERAL SPECIFICATIONS</b>		<b>GROUP 10 - TUNE-UP AND ADJUSTMENTS</b>	
Specifications .....	10-00-02	Preliminary Engine Testing .....	10-10-01
Dimensions .....	10-00-05	Engine Tune-Up .....	10-10-01
Serial Numbers .....	10-00-07	Standard Torques .....	10-10-02
<b>GROUP 05 - PREDELIVERY, DELIVERY, AND AFTER SALE INSPECTION</b>		<b>GROUP 15 - LUBRICATION</b>	
Predelivery Service .....	10-05-01	Fuels .....	10-15-01
Delivery Service .....	10-05-22	Engine Oils .....	10-15-01
After-Sale Inspection .....	10-05-22	Transmission and Hydraulic Oils .....	10-15-02
		Picker Bar and Spindle Lubricants .....	10-15-02
		Greases .....	10-15-03
		Special Lubricants .....	10-15-03
		Lubrication .....	10-15-04

A68; M01;1000 A 100583

**SPECIFICATIONS**

**ROW WIDTHS** . . . . . (0.96 to 1.02 m) 38 to 40-inch

**PICKING UNITS**

Number of units . . . . . 4  
 Number of picking drums . . . . . 8  
 Number of picker bars (per unit)  
     Front drum . . . . . 12  
     Rear drum . . . . . 12  
 Number of spindles (per machine) . . . . . 1920

**PICKING UNIT SPEEDS**

**rpm**

Picking Unit Drive Shaft . . . . . 1280  
 Picking Drum . . . . . 0-145  
 Doffer Shaft . . . . . 0-1755  
 Spindle . . . . . 0-4020

**GROUND SPEEDS (FULL THROTTLE)**

**Picking Speeds**  
     1st Gear . . . . . (0-5.14 km/h) 0-3.2 mph  
     2nd Gear . . . . . (0-6.05 km/h) 0-3.8 mph  
  
**Transport Speeds**  
     3rd Gear . . . . . (0-21.56 km/h) 0-13.4 mph  
  
 Reverse . . . . . (0-11.94 km/h) 0-7 mph

**CAPACITIES**

Cotton basket (standard) . . . . . (24.2 m<sup>3</sup>) 856 cu ft  
 Cotton basket (with [305 mm]12-in. extension) . . . . . (28.4 m<sup>3</sup>) 1004 cu ft  
     with [605 mm]24-in. extension) . . . . . (32.3 m<sup>3</sup>) 1152 cu ft  
  
 Fuel tank . . . . . (356 L) 94 gal  
 Water tank . . . . . (870.5 L) 230 gal  
 Cooling system . . . . . (42 L) 44 qt  
 Thermostat (each) . . . . . (82°C) 180°F  
 Engine crankcase, including filter . . . . . (20 L) 21 qt  
  
 Hydraulic system, including filter . . . . . (26.5 L) 28 qt  
 Hydraulic Reservoir . . . . . (17.4 L) 18.4 qt  
 Transmission and Final Drive . . . . . (31.2 L) 33 qt  
 Hydrostatic drive . . . . . (26.5 L) 28 qt  
 Hydrostatic Reservoir . . . . . (17 L) 18.4 qt

N01;1000 B 220585

General Specifications

**TIRES**

Front drive wheels. . . . . 18.4 x 38 10 PR (R1, R2)  
Rear guide wheels. . . . . 9.00 x 24 6 PR 1

**TIRE INFLATION PRESSURE**

Drive wheels . . . . . (210 kPa) 30 psi  
Guide wheels. . . . . (252 kPa) 36 psi

**HYDROSTATIC DRIVE**

Make  
Motor and Pump (S.N. -736) . . . . . Sundstrand  
(S.N. 737- ) . . . . . Eaton  
Type of oil filter . . . . . Full flow suction  
Type of cooler . . . . . Air-cooled

**WEIGHT**

(less basket extensions) . . . . . (10,170 kg) 22,600 lb  
with [305 mm ] 21-in. extension) . . . . . (10,442 kg) 23,000 lb  
with [610 mm ] 24-in. extension) . . . . . (10,533 kg) 23,200 lb

**FINAL DRIVE**

Type. . . . . Planetary

**ELECTRICAL SYSTEM**

Battery voltage. . . . . 12-volts  
Battery terminal grounded . . . . . Negative  
Alternator (S.N. -736) . . . . . 72 Amp  
(S.N. 737- ) . . . . . 90 Amp  
Monitor Light Bulb . . . . . OAH94791  
Headlight Bulb . . . . . Mfg. Type 4460  
Tail Light Bulb . . . . . Mfg. Type 1157  
Warning Light Bulb . . . . . Mfg. Type 1156 Front; 1596 Rear  
Field Light Bulb (Standard). . . . . Mfg. Type 4411  
(Halogen). . . . . Mfg. Type H7610

**ENGINE**

Manufacturer . . . . . John Deere  
Model . . . . . 6466AN-01 Turbocharged, Intercooled  
No. of cylinders . . . . . 6  
Bore . . . . . (116 mm) 4.56-in.  
Stroke . . . . . (121 mm) 4.75-in.  
Displacement. . . . . (7640 cm<sup>3</sup>) 466 cu in  
Horsepower . . . . . (154 kW) 207 hp  
Compression ratio . . . . . 14.9 to 1  
Firing order . . . . . 1-5-3-6-2-4  
Tappet clearance  
Intake. . . . . (0.46 mm) 0.018-in.  
Exhaust. . . . . (0.71 mm) 0.028-in.  
Fuel injection pump . . . . . Bosch  
Injection pump timing . . . . . TDC  
Engine speeds  
Fast idle (no load) . . . . . 2375-2425 rpm  
Rated (under field load) . . . . . 2200 rpm  
Slow idle . . . . . 800-900 rpm  
Muffler . . . . . Regular

A68; N01;1000 C 061284



General Specifications

**OPERATOR'S CAB**

Type ..... SOUND-GARD® (with no ROPS) with heater,  
windshield wiper, rear view mirror, seat  
suspension, and posture contour seat  
Optional Attachment ..... PERSONAL-POSTURE™ Seat, Air Conditioner  
Dome Light Bulb ..... 12-volt, Type 105 (AR86969)  
Console Light Bulb ..... 12-volt, Type 168 (AR48015)  
Filter  
Primary ..... JD-AR61903  
Secondary ..... JD-AH92463

**CIRCUIT BREAKERS**

Lighting, Ignition and Accessories ..... Five 20-amp (on engine)  
Blower and Dome Light ..... 30-amp (on engine)  
Windshield Wiper ..... 6-amp (in switch)

**WINDSHIELD WIPER**

Blade Length ..... (508 mm) 20 in.  
Arm Length ..... (508 mm) 20 in.

**HEATER CAPACITY** ..... (5274 W/hr) 18,000 BTU

**AIR CONDITIONER**

Make (Compressor) ..... Delco  
Capacity ..... (6446 W/hr) 22,000 BTU  
Refrigerant ..... Refrigerant R-12  
Refrigerant Charge ..... Approx (2.5 kg) 5-1/2 lb

A68; N01;1000 D 110483

General Specifications

**DIMENSIONS**

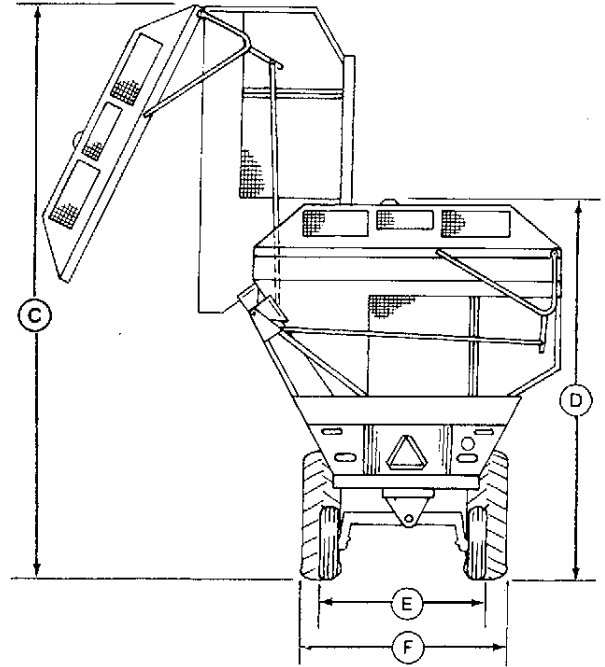
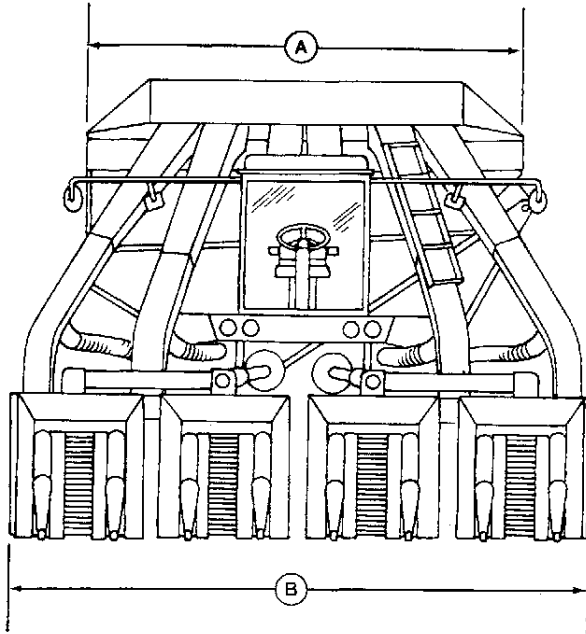

- A—(3607 mm) 142"
- B—(3861 mm) 152", (0.96 m) 38" rows  
(4013 mm) 158", (1.02 m) 40" rows
- C—(6.896 m) 271-1/2' maximum dumping height

- D—(4191 mm) 165" (standard)  
(4496 mm) 177" (with short extension)  
(4801 mm) 189" (with long extension)
- E—(2261 mm) 89"
- F—(2502 mm) 98-1/2"

A68.N35705, N35706 N01:000 E 261180

General Specifications

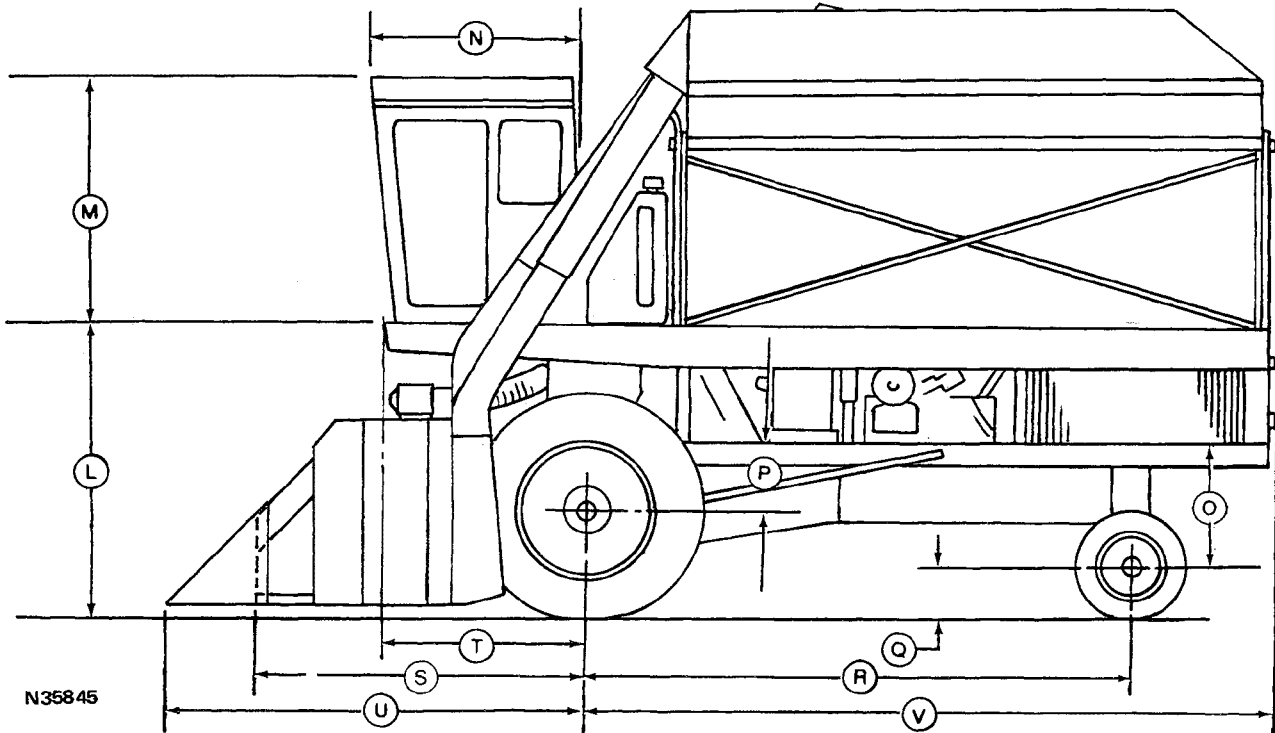

L—(2 096 mm) 82-1/2"  
M—(1 638 mm) 64-1/2"  
N—(1 740 mm) 68-1/2"  
O—(807 mm) 31-3/4"

P—(489 mm) 19-1/4"  
Q—(508 mm) 20"  
R—(3 321 mm) 130-3/4"  
S—(2 540 mm) 100"

T—(1 454 mm) 57-1/4"  
U—(3 099 mm) 122"  
V—(4 521 mm) 178"

A68/N35845 N01:1000 F 261180

## *General Specifications*

### **SERIAL NUMBERS**

Use serial numbers in all correspondence with the factory on the following items.

The engine serial number is located on the left-hand side of the engine block.

The cotton picker serial number is located at the left-hand top of the housing support.

The hydrostatic motor and pump serial number is located on top of the pump.

The cab serial number is located on the inside left-hand rear corner of the cab.

A68; N01;1000 G 261180