

JOHN DEERE 7610 AND 7620 KNUCKLEBOOM LOADERS



TECHNICAL MANUAL JOHN DEERE 7610 AND 7620 KNUCKLEBOOM LOADERS

TM1146 (01SEP75) English

TM1146 (01SEP75)

LITHO IN THE U.S.A.
ENGLISH

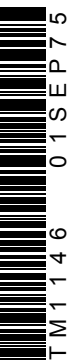

7610 AND 7620 KNUCKLEBOOM LOADERS

Technical Manual
TM-1146 (Sep-75)

CONTENTS

SECTION 10-GENERAL

- Group 5 Specifications
- Group 10 Lubrication
- Group 15 Loader Installation and Separation

SECTION 20-ENGINE

- Group 5 Diagnosing Malfunctions
- Group 10 Separation and Installation
- Group 15 Basic Engine
- Group 20 Engine Lubrication
- Group 25 Speed Control Linkage
- Group 30 Engine Cooling System
- Group 35 Specifications and Special Tools

SECTION 30-FUEL SYSTEM

- Group 5 Diagnosing Malfunctions
- Group 10 Fuel Tank, Fuel Filter and Fuel Transfer Pump
- Group 15 Fuel Injection Pump
- Group 20 Specifications

SECTION 40-ELECTRICAL SYSTEM

- Group 5 Wiring Diagrams
- Group 10 Charging System
- Group 15 Starting Motor
- Group 20 Specifications

SECTION 50-HYDRAULIC SYSTEM

- Group 5 Malfunction Diagnosis
- Group 10 Hydraulic Pump
- Group 15 Reservoir and Filters
- Group 20 Main Valve
- Group 25 Stabilizer Valve
- Group 30 Control Levers Linkage
- Group 35 Hydraulic Cylinders
- Group 40 Grapple Inline Crossover Relief Valve
- Group 45 Grapple Orbit Motor
- Group 50 Grapple High Torque Orbit Motor
- Group 55 Specifications

The specifications and design information contained in this manual were correct at the time it was printed. It is John Deere's policy to continually improve and update our machines. Therefore, the specifications and design information are subject to change without notice. Wherever applicable, specifications and design information are in accordance with SAE and IEMC standards.

SI (International System)
Units of Measure

Metric equivalents have been included, where applicable, throughout this technical manual.

Copyright© 1975
DEERE & COMPANY
Moline, Illinois
All rights reserved

**Thanks very much for your reading,
Want to get more information,
Please click here, Then get the complete
manual**

JustClickHere 

NOTE:

**If there is no response to click on the link above,
please download the PDF document first, and then
click on it.**

**Have any questions please write to me:
admin@servicemanualperfect.com**

INTRODUCTION

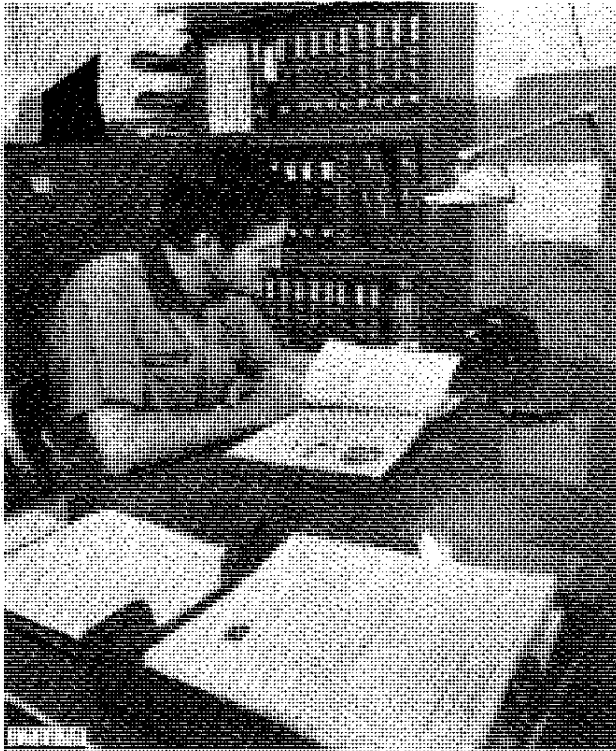

Use FOS Manuals for Reference

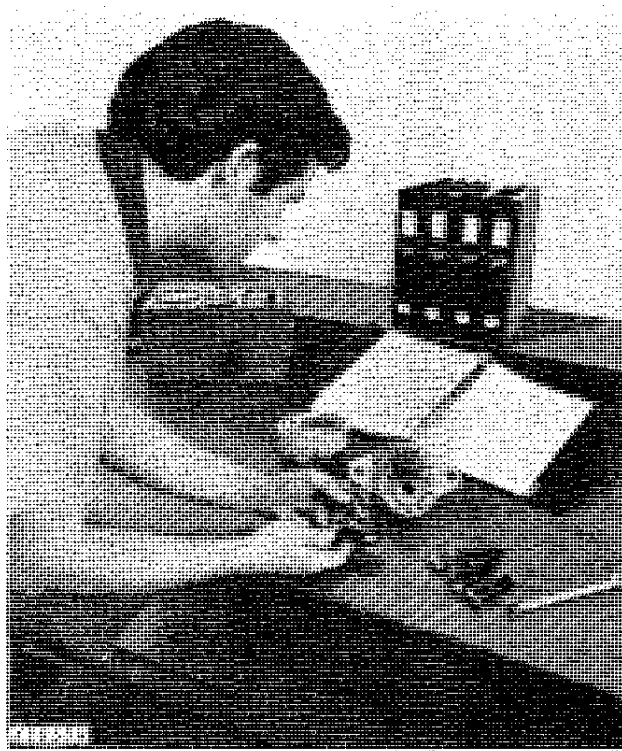

Use Technical Manuals for Actual Service

This technical manual is part of a twin concept of service:

- **FOS Manuals—**for reference
- **Technical Manuals—**for actual service

The two kinds of manuals work as a team to give you both the general background and technical details of shop service.

Fundamentals of Service (FOS) Manuals cover basic theory of operation, *fundamentals* of trouble shooting, *general* maintenance, and *basic* types of failures and their causes. FOS Manuals are for training new men and for reference by experienced men.

Technical Manuals are concise on-the-job service guides containing only the vital information needed for a specific machine.

Some features of this technical manual:

- *Table of contents at front of manual*
- *Exploded views showing parts relationship*
- *Photos showing service techniques*
- *Specifications grouped for easy reference*

This technical manual was planned and written for you—a journeyman mechanic. Keep it in a permanent binder in the shop where it is handy. Refer to it whenever in doubt about correct service procedures or specifications.

Using the technical manual as a guide will reduce error and costly delay. It will also assure you the best in finished service work.

 This safety alert symbol identifies important safety messages in this manual. When you see this symbol, be alert to the possibility of personal injury and carefully read the message that follows.

SAFETY AND YOU

INTRODUCTION

 This safety alert symbol identifies important safety messages in this manual and on the knuckleboom loader. When you see this symbol, be alert to the possibility of bodily injury and carefully read the message that follows.



T27999N

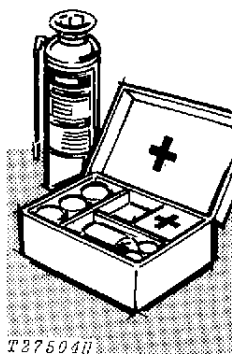

T27504II

Be prepared if an accident or fire should occur. Know where the first aid kit and the fire extinguishers are located—know how to use them.

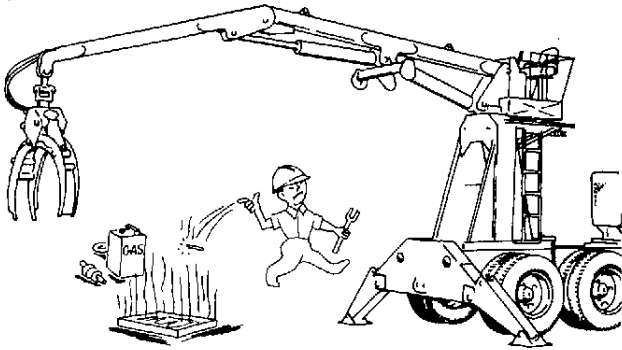
AVOID FIRE HAZARDS

G8116N

WRONG

Don't smoke while refueling or handling highly flammable material.

Shut off engine when refueling.

Use care in refueling if the engine is hot.

Don't use open pans of gasoline or diesel fuel for cleaning parts. Good commercial, nonflammable solvents are preferred.

Provide adequate ventilation when charging batteries.

Don't check battery charge by placing metal objects across the posts.

Don't allow sparks or open flame near batteries.

Don't smoke near battery.

Never check fuel, battery electrolyte, or coolant levels with an open flame.

Never use an open flame to look for leaks anywhere on the equipment.

Never use an open flame as a light anywhere on or around the equipment.

When preparing engine for storage, remember that internal corrosion inhibitor is volatile and therefore dangerous. Seal and tape openings after adding the inhibitor. Keep container tightly closed when not in use.

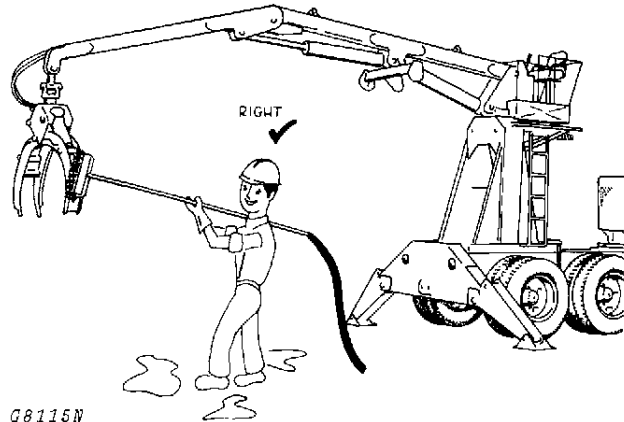
CLEANING THE LOADER

G8115N

RIGHT

Always stop the engine before cleaning the loader.

Keep the operator's platform clean. Do not use it as a storage area.

Keep the engine closure screens free of foreign matter. Avoid a possible fire hazard.

Keep all equipment free of dirt and oil. In freezing weather, beware of snow and ice on operator's platform.

SERVICE AREA

Keep the service area clean and dry. Wet or oily floors are slippery. Wet spots can be dangerous when working with electrical equipment.

Make sure the service area is adequately vented.

Periodically check the shop exhaust system for leakage. Engine exhaust gas is dangerous.

Be sure all electrical outlets and tools are properly grounded.

Use adequate light for the job at hand.

FLUIDS UNDER PRESSURE

Escaping fluid under pressure can have sufficient force to penetrate the skin, causing serious bodily injury. Before disconnecting lines, be sure to relieve all pressure. Before applying pressure to the system, be sure all connections are tight and that lines, pipes and hoses are not damaged. Fluid escaping from a very small hole can be almost invisible. Use a piece of cardboard or wood, rather than hands, to search for suspected leaks.

If injured by escaping fluid, see a doctor at once. Serious infection or reaction can develop if proper medical treatment is not administered immediately.

Don't forget the hydraulic system may be pressurized! To relieve pressure, follow the technical manual.

When checking hydraulic pressure, be sure to use the correct test gauge for the pressure in the particular system.

PERSONAL SAFETY



Always avoid loose clothing—flopping cuffs, dangling neckties and scarves—that can catch in moving parts and put you out of work.

Always wear your safety glasses while on the job.

Keep transmission and brake control units properly adjusted at all times. Before making adjustments, stop engine.

Before removing any housing covers, stop engine. Take all objects from your pockets which could fall into the opened housings. Don't let adjusting wrenches fall into opened housings.

Don't attempt to check chain belt tension while the engine is running.

Don't adjust the fuel system while the machine is in motion.

Before repairing the electrical system, for performing a major overhaul, make sure the batteries are disconnected.

Avoid working on equipment with the engine running. If it is necessary to make checks with the engine running, **ALWAYS USE TWO MEN**—one, the operator, at the controls, the other checking where the operator can see him. Also, set the brake, and apply any safety locks provided. **KEEP HANDS AWAY FROM MOVING PARTS.**

Use extreme caution in removing drain plugs, grease fittings, or hydraulic pressure caps.

Section 10 GENERAL

CONTENTS OF THIS SECTION

GROUP 5 - SPECIFICATIONS	Page	GROUP 15 - LOADER INSTALLATION AND SEPARATION	Page
7610 Specifications.....	5-3—5-5	Separation.....	15-1—15-3
Lift Capacities for 7610 Front and Rear Mount.....	5-5	Installation.....	15-3—15-4
7620 Specifications.....	5-6—5-8		
Lift Capacities for 7620 Front and Rear Mount.....	5-8		
 GROUP 10 - LUBRICATION			
Engine Lubricating Oils.....	10-1		
Storing Lubricants.....	10-1		
Hydraulic Oils.....	10-1		
Greases.....	10-1		
Lubrication.....	10-2		
Lubrication and Service Intervals.....	10-2		
Periodic Service Chart.....	10-3		
Every 10 Hours or Daily.....	10-4		
Every 100 Hours.....	10-6		
Every 500 Hours or Twice Yearly.....	10-7		

Group 5 SPECIFICATIONS

7610 KNUCKLEBOOM LOADER

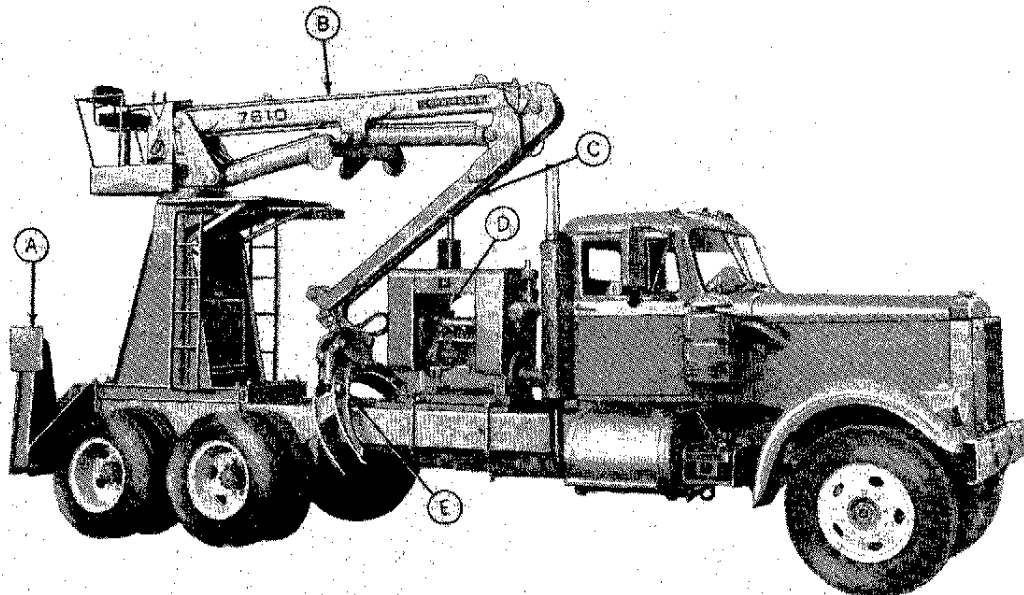

06951

A—Stabilizer
B—Main Boom
C—Jib Boom

D—Auxiliary Engine
E—Grapple

Fig. 1-7610 Knuckleboom Loader (Rear Mount Illustrated)

Two hand levers and one foot control with safety lock

Mounts behind cab or on rear of truck frame

Lifts up to 14,700 lb. (6 668 kg)

21 ft. 6 in. (6.553 mm) reach

Loader rotation—380 degrees

Grapple rotation—360 degrees

40-in. (1.016 m) interlocking grapple or 1/4-cord general-purpose grapple

PTO-driven or engine-driven

Double access platform with safety decking and rail

Stabilizer with 16 x 16-in. (406 x 406 mm) foot pads

Cushion seat with armrests

7610 SPECIFICATIONS

Operating Information:

Maximum loading reach ... 21 ft. 6-in. (6 553 mm)
Swing system..... Chain
Swing arc 380°
Boom swing torque..... 16,000 lb-ft (2212 kg-m)
Swing speed..... 5 rpm
Stabilizer spread:
 Front 11-ft. 6-in. (3.505 m)
 Rear 15-ft. 4-in. (4.674 m)
Stabilizer area (each)..... 256 sq. in. (1652 cm²)
Grapple rotation 360°
Grapple swing torque 175 lb-ft (24.2 kg-m)
Grapple opening, maximum:
 40 in. (1.02 m) grapple 40-in. (1 016 mm)
 1/4-cord grapple 50-in. (1 270 mm)
Transport height 13-ft. 3-in. (4 039 mm)
Maximum transport width 8-ft. (2 438 mm)

Mounting:

Mounting frame integral with main frame. Brackets supplied for universal mounting; bolts to truck frame.

Hydraulic Cylinders:

Main 6x36-in. (152x914mm), double-acting
Jib 6x36-in. (152x914mm), double-acting
Boom swing 6x23-1/4-in. (152x591mm), single-acting
Grapple 3-1/2x8-in. (89x203mm), double-acting
Stabilizer 6x21-in. (152x533mm), double-acting

Hydraulic System:

Controls 2-lever, stack valve
Relief pressure..... 1850 psi (127.5 bar)
Pump 60 gpm (227 l) at 1800 rpm
Reservoir capacity..... 52 gal. (196.8 l)
Drive Truck transmission power take-off or auxiliary engine

Special Auxiliary Diesel Power Unit: (rear mount only)

John Deere, 4-cylinder, valve-in-head, 4-stroke cycle. Power @ 2500 rpm, intermittent, 70 hp

Bore and stroke 4.02x4.33 in. (102x110 mm)
Piston displacement 219 cu. in. (3589 cm³)
Rotation, facing flywheel end..... Counterclockwise
Compression ratio 16.3 to 1
Alternator 12 volt, 35 amp w/regulator
Starter..... 12 volt (no battery and cables)

Shipping Weight (approx.):

Complete with stabilizer, all cylinders, hydraulic pump and all mountings, less grapples:
 Behind cab 5841 lb. (2649 kg)
 Rear-mount..... 6688 lb. (3034 kg)
Grapples:
 40-in. (1.02 m) interlocking ... 585 lbs. (265 kg)
 1/4-cord general-purpose 620 lbs. (281 kg)
Diesel power unit 1350 lbs. (612 kg)

LIFT CAPACITIES FOR 7610 FRONT AND REAR MOUNT

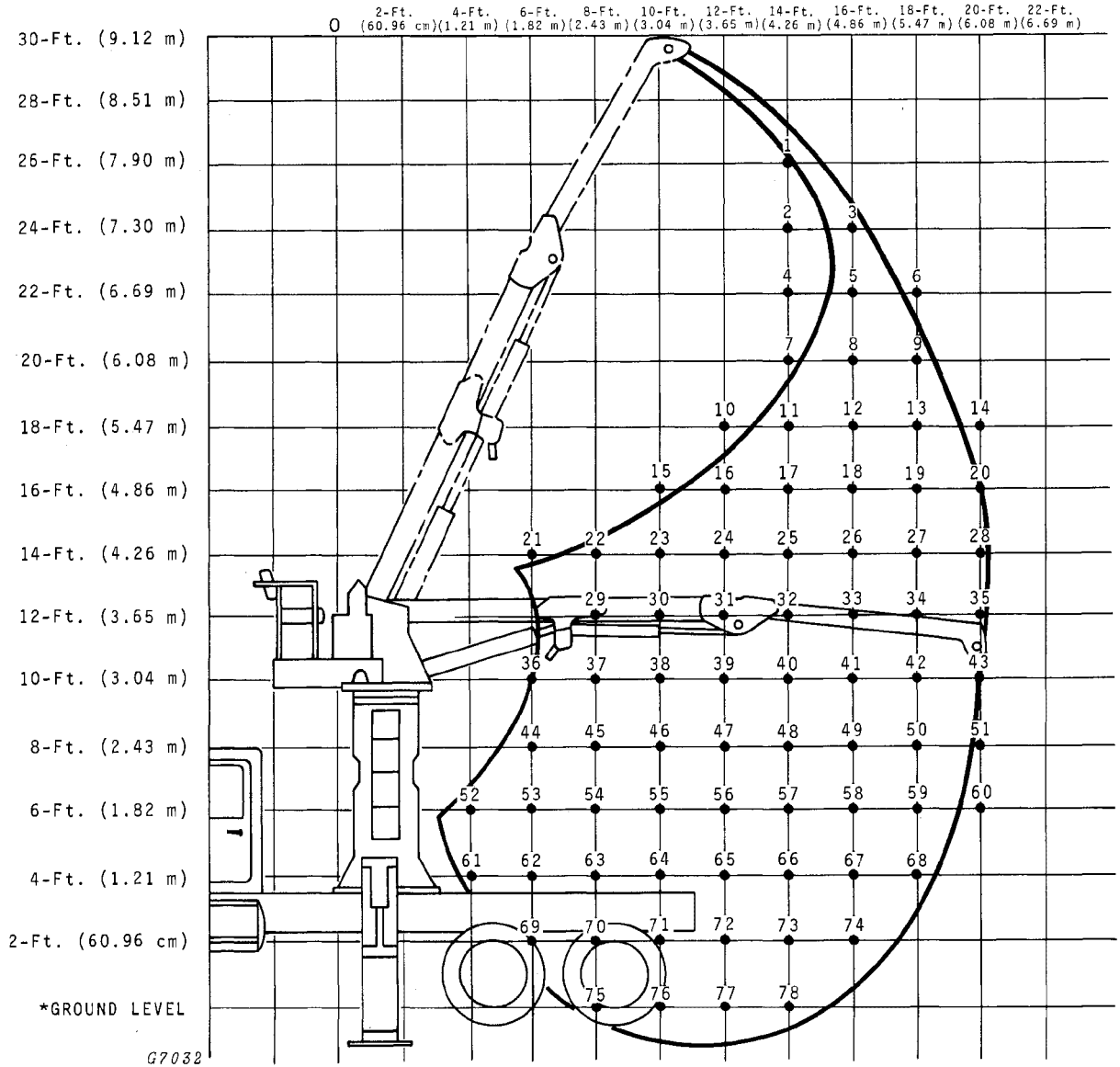

1—6000 lbs. (26.7 kN)	12—5930 lbs. (26.4 kN)	23—9280 lbs. (41.3kN)	34—5600 lbs. (24.9 kN)	45—12,340 lbs. (54.9 kN)	56—8320 lbs. (37.0 kN)	67—5460 lbs. (24.3 kN)
2—6080 lbs. (27.0 kN)	13—5470 lbs. (24.3 kN)	24—7940 lbs. (35.3 kN)	35—4870 lbs. (21.7 kN)	46—10,310 lbs. (45.9 kN)	57—7030 lbs. (31.3 kN)	68—4330 lbs. (19.3 kN)
3—5480 lbs. (24.4 kN)	14—3740 lbs. (16.6 kN)	25—6970 lbs. (31.0 kN)	36—5270 lbs. (23.4 kN)	47—8560 lbs. (38.1 kN)	58—5980 lbs. (26.6 kN)	69—9570 lbs. (42.6 kN)
4—6100 lbs. (27.1 kN)	15—8560 lbs. (38.9 kN)	26—6220 lbs. (27.7 kN)	37—12,860 lbs. (57.2 kN)	48—7270 lbs. (32.3 kN)	59—4990 lbs. (22.2 kN)	70—9650 lbs. (42.9 kN)
5—5760 lbs. (25.6 kN)	16—7500 lbs. (33.4 kN)	27—5580 lbs. (24.8 kN)	38—10,270 lbs. (45.7 kN)	49—6250 lbs. (27.8 kN)	60—3400 lbs. (15.1 kN)	71—8160 lbs. (36.3 kN)
6—4640 lbs. (20.6 kN)	17—6700 lbs. (29.8 kN)	28—4940 lbs. (22.0 kN)	39—8540 lbs. (38.0 kN)	50—5350 lbs. (23.8 kN)	61—5510 lbs. (23.8 kN)	72—6880 lbs. (30.6 kN)
7—6230 lbs. (27.7 kN)	18—6070 lbs. (27.0 kN)	29—12,310 lbs. (54.8 kN)	40—7300 lbs. (32.5 kN)	51—4330 lbs. (19.3 kN)	62—8350 lbs. (37.1 kN)	73—5730 lbs. (25.5 kN)
8—5610 lbs. (25.8 kN)	19—5530 lbs. (24.6 kN)	30—9890 lbs. (44.0 kN)	41—6350 lbs. (28.2 kN)	52—3680 lbs. (16.4 kN)	63—11,180 lbs. (49.7 kN)	74—4610 lbs. (20.5 kN)
9—5440 lbs. (24.2 kN)	20—4480 lbs. (19.9 kN)	31—8310 lbs. (37.0 kN)	42—5530 lbs. (24.6 kN)	53—6750 lbs. (30.0 kN)	64—9270 lbs. (41.2 kN)	75—7630 lbs. (33.9 kN)
10—7080 lbs. (31.5 kN)	21—14,710 lbs. (65.4 kN)	32—7190 lbs. (32.0 kN)	43—4680 lbs. (20.8 kN)	54—11,650 lbs. (51.8 kN)	65—7770 lbs. (34.6 kN)	76—6600 lbs. (29.4 kN)
11—6450 lbs. (28.7 kN)	22—11,290 lbs. (50.2 kN)	33—6320 lbs. (28.1 kN)	44—5540 lbs. (24.6 kN)	55—9980 lbs. (44.4 kN)	66—6550 lbs. (29.1 kN)	77—5560 lbs. (24.7 kN)
						78—4480 lbs. (19.9 kN)

* Height is measured from centerline of pin connecting grapple to boom as installed on 42 in. (1 067 mm) truck bed height.

Actual lift values as installed on truck with stabilizers emplaced on hard surface and with 100% stability.

Fig. 2-Lift capacities for 7610 Front and Rear Mount

7620 KNUCKLEBOOM LOADER

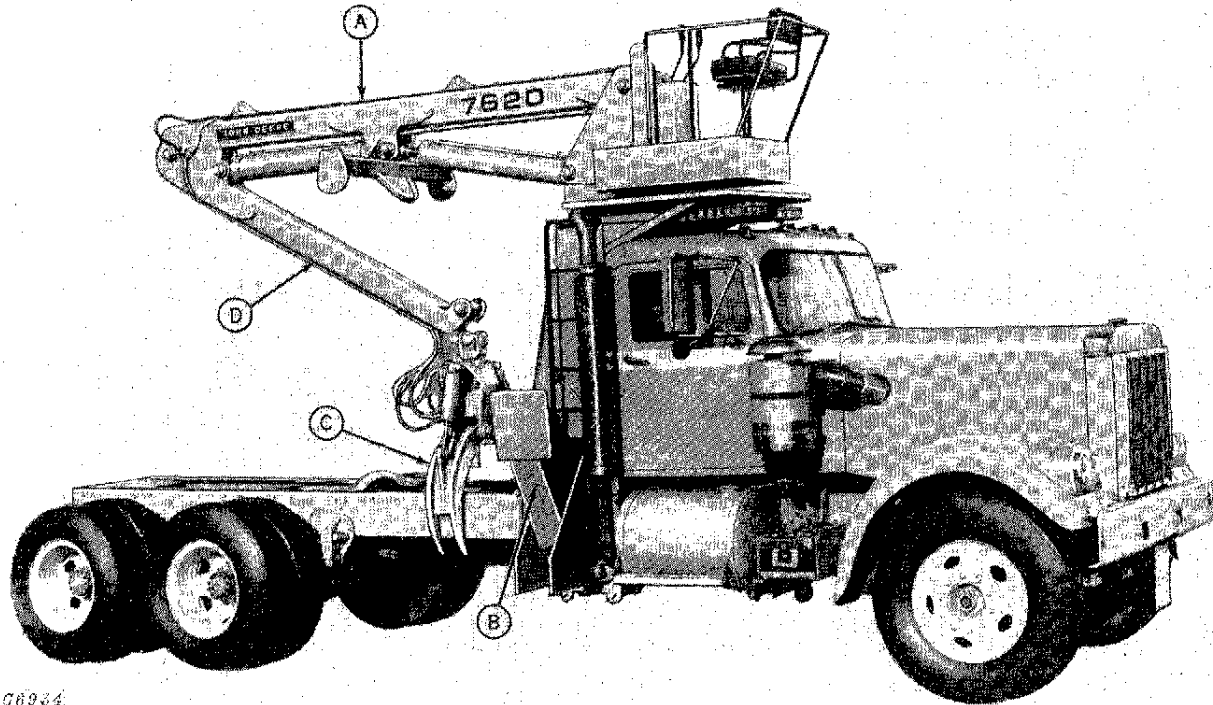

A—Main Boom
B—Stabilizer

C—Grapple
D—Jib Boom

Fig. 3-7620 Knuckleboom Loader (Front Mount Illustrated)

Two hand levers with safety lock and one foot control

Mounts behind cab or on rear of truck frame

Lifts up to 20,600 lb. (9344 kg)

21-ft. 6-in. (6 553 mm) reach

Loader rotation—380 degrees

Grapple rotation—360 degrees

Choice of 40-in. (1 016 mm) or 44-in. (1 118 mm) interlocking grapple, or 1/4 cord general-purpose grapple

PTO-driven or engine-driven

Double-access platform with safety decking and rail

Stabilizer with 16 x 16-in. (406 x 406 mm) foot pads

Cushion seat with armrests

LIFT CAPACITIES FOR 7620 FRONT AND REAR MOUNT

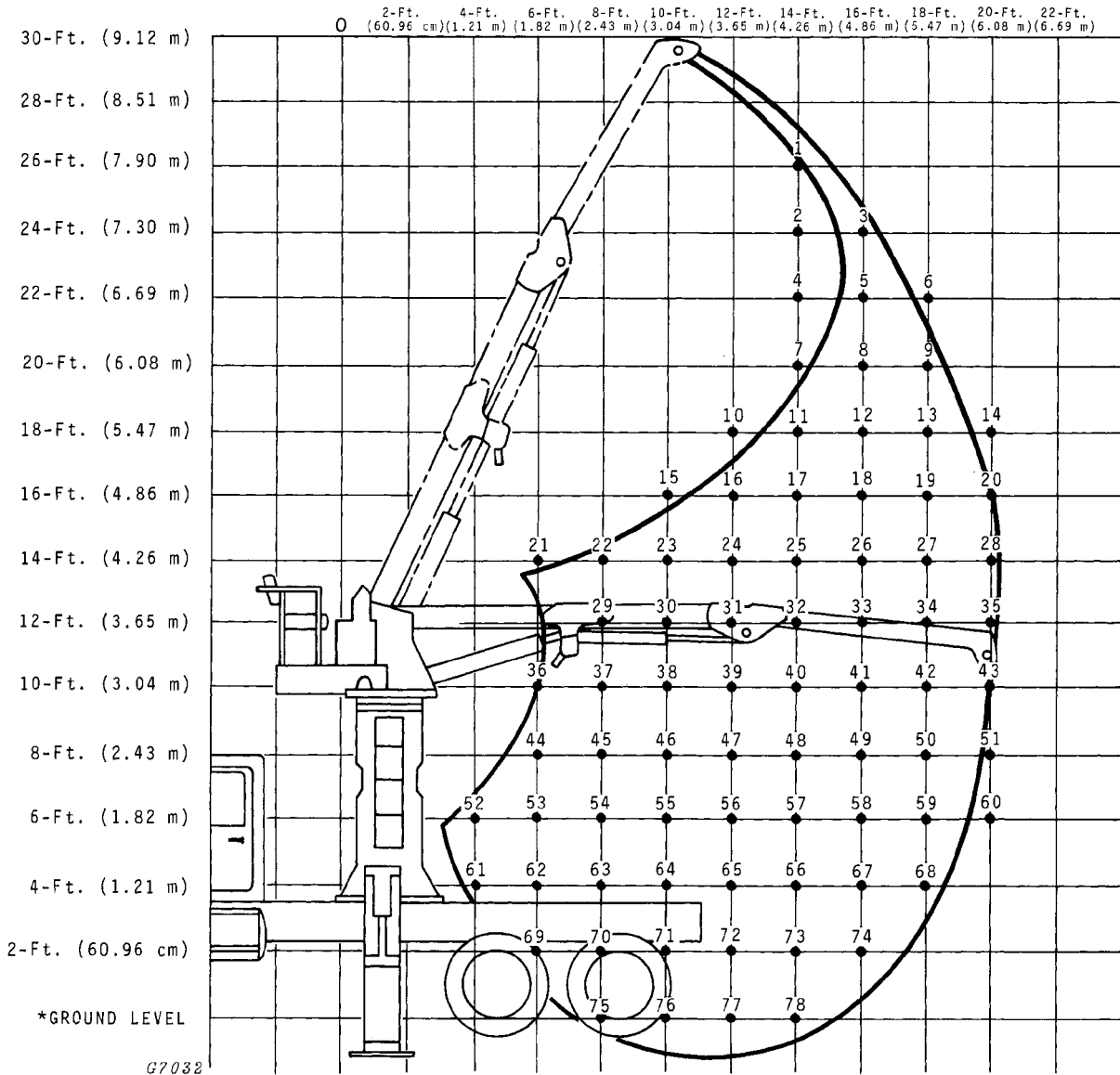

1—6960 lbs. (31.0 kN)	12—8340 lbs. (37.1 kN)	23—13,830 lbs. (61.5 kN)	34—8070 lbs. (35.9 kN)	45—14,180 lbs. (63.1 kN)	56—11,910 lbs. (53.0 kN)	67—7940 lbs. (35.3 kN)
2—7446 lbs. (33.1 kN)	13—6740 lbs. (30.0 kN)	24—11,280 lbs. (50.2 kN)	35—6030 lbs. (26.8 kN)	46—14,670 lbs. (65.3 kN)	57—10,110 lbs. (45.0 kN)	68—6370 lbs. (28.3 kN)
3—6350 lbs. (28.2 kN)	14—3740 lbs. (16.6 kN)	25—9950 lbs. (44.3 kN)	36—5270 lbs. (23.4 kN)	47—12,220 lbs. (54.4 kN)	58—8640 lbs. (38.4 kN)	69—10,150 lbs. (45.1 kN)
4—7690 lbs. (34.2 kN)	15—12,090 lbs. (53.8 kN)	26—8910 lbs. (39.6 kN)	37—17,860 lbs. (79.4 kN)	48—10,420 lbs. (46.4 kN)	59—7460 lbs. (32.3 kN)	70—13,890 lbs. (61.8 kN)
5—7070 lbs. (31.4 kN)	16—10,650 lbs. (47.4 kN)	27—8040 lbs. (35.8 kN)	38—14,580 lbs. (64.9 kN)	49—9000 lbs. (40.0 kN)	60—3980 lbs. (17.7 kN)	71—11,770 lbs. (52.4 kN)
6—4980 lbs. (22.2 kN)	17—9550 lbs. (42.5 kN)	28—6130 lbs. (27.3 kN)	39—12,170 lbs. (54.1 kN)	50—7760 lbs. (34.5 kN)	61—5510 lbs. (24.5 kN)	72—9950 lbs. (44.3 kN)
7—8460 lbs. (37.6 kN)	18—8700 lbs. (38.7 kN)	29—17,390 lbs. (77.4 kN)	40—10,450 lbs. (46.5 kN)	51—5390 lbs. (24.0 kN)	62—8350 lbs. (37.1 kN)	73—8340 lbs. (37.1 kN)
8—7450 lbs. (33.1 kN)	19—7460 lbs. (33.2 kN)	30—14,020 lbs. (62.4 kN)	41—9120 lbs. (40.6 kN)	52—3680 lbs. (16.4 kN)	63—13,720 lbs. (61.0 kN)	74—6770 lbs. (30.1 kN)
9—6550 lbs. (29.1 kN)	20—5200 lbs. (23.1 kN)	31—11,830 lbs. (52.6 kN)	42—8000 lbs. (35.6 kN)	53—6750 lbs. (30.0 kN)	64—13,290 lbs. (59.1 kN)	75—11,120 lbs. (49.5 kN)
10—9990 lbs. (44.4 kN)	21—20,630 lbs. (91.8 kN)	32—10,270 lbs. (45.7 kN)	43—5820 lbs. (25.9 kN)	54—13,400 lbs. (59.6 kN)	65—11,170 lbs. (49.7 kN)	76—9620 lbs. (42.8 kN)
11—9180 lbs. (40.8 kN)	22—15,910 lbs. (70.8 kN)	33—9070 lbs. (40.3 kN)	44—5640 lbs. (24.6 kN)	55—14,250 lbs. (63.4 kN)	66—9450 lbs. (42.0 kN)	77—8140 lbs. (36.2 kN)
						78—6620 lbs. (29.4 kN)

* Height is measured from centerline of pin connecting grapple to boom as installed on 42 in. (1 067 mm) truck bed height.

Actual lift values as installed on truck with stabilizers emplaced on hard surface and with 100% stability.

Fig. 4—Lift Capacities for 7620 Front and Rear Mount

Group 10 LUBRICATION

LUBRICANTS

Effective use of lubricating oils and greases is perhaps the most important step towards low upkeep cost, long engine life, and satisfactory service. Use only lubricants specified in this section; apply them at intervals and according to the instructions in the lubrication and periodic service section.

ENGINE LUBRICATING OILS



We recommend John Deere Torq-Gard Supreme engine oil for use in the engine crankcase. This oil is compounded specifically for use in John Deere engines and provides superior lubrication under all conditions. **NEVER PUT ADDITIVES IN THE CRANKCASE.** Torq-Gard Supreme oil is formulated to provide all the protection your engine needs. Additives could reduce this protection rather than help it.

If oil other than Torq-Gard Supreme is used, it must conform to one of the following specifications for all John Deere engines:

SINGLE VISCOSITY OILS

API Service CD/SD
MIL-L-2104C
Series 3

MULTI-VISCOSITY OILS

API Service CC/SD
MIL-L-46152

Depending on the expected prevailing temperature for the fill period, use oil viscosity as shown in the following chart.

Air Temperature	John Deere Torq-Gard Oil	Other Oils	
		Single Viscosity Oil	Multi-Viscosity Oil
Above 32°F (0°C)	SAE 30	SAE 30	Not recommended
-10°F to 32°F (-23°C to 0°C)*	SAE 10W-20	SAE 10W	SAE 10W-30
Below 10°F (-23°C)	SAE 5W-20	SAE 5W	SAE 5W-20

*SAE 5W-20 oil may also be used to insure optimum lubrication at starting, particularly when engine is subjected to -10°F (-23°C) or lower temperatures for several hours.

Some increase in oil consumption may be expected when SAE 5W-20 or SAE 5W oils are used. Check oil level more frequently.

STORING LUBRICANTS

Your engine can operate at top efficiency only if clean lubricants are used. Use clean containers to handle all lubricants. Store them in an area protected from dust, moisture, and other contamination.

Do not handicap your engine by using inferior or incorrect oil and grease. Use only quality lubricants at the specified intervals.

HYDRAULIC OILS

Use only John Deere Hy-Gard oil or its equivalent in the hydraulic system reservoir.

GREASES

Use John Deere Multi-Purpose Lubricant or an equivalent SAE multipurpose-type grease for all grease fittings. Application of grease as instructed in the lubrication section will provide proper lubrication and will keep loader in top operating condition.

LUBRICATION

The instructions on the following pages will help you perform recommended service at proper intervals. Performing the services as instructed will result in a long, reliable service life.

The intervals at which the various working parts of your knuckleboom should be checked, lubricated, serviced, or adjusted are based on hours of operation.

NOTE: For engine lubrication refer to the engine operator's manual.

After the first 50 hours of loader operation change the return line filter in the loader reservoir.

KEEP LUBRICANTS CLEAN

Use only high-grade lubricants which have been stored in clean containers. Wipe away all grease and dirt before removing filler caps or plugs.

SYMBOLS



Lubricate with John Deere Multi-Purpose Lubricant or an equivalent SAE multipurpose-type grease at hourly intervals indicated on the symbols.



Lubricate Every 500 Hours of Operation with John Deere Hy-Gard Oil or its equivalent.

Note that lubrication intervals on the symbols are identical to those appearing in the operator's manual. Regardless of recommended intervals, lubricate the loader before delivery at every point shown in the charts. When you deliver the loader, the time interval information will remind you to tell your customer of the importance of lubrication intervals recommended in his operator's manual.

LUBRICATION AND SERVICE INTERVALS

The lubrication and service intervals for this knuckleboom are based on operation under average conditions. When the knuckleboom is operated under unusual conditions, such as excessive heat, cold, dust, frequent starts and stops, or with poor quality fuels or lubricants, the knuckleboom should be serviced at **MORE FREQUENT INTERVALS**.

The chart which follows is a condensed list of the knuckleboom components to be serviced at each interval and the service to be performed. Detailed instructions for performing each service are given on the pages which follow the chart. Each item in the chart is numbered, with the corresponding detailed procedure bearing the same number.

Perform the indicated services at the time intervals specified in the chart.